



AGENDA

CITY OF CAMDEN

CITY COUNCIL REGULAR MEETING

March 12th, 2024 – 5:00 p.m.

Honorable Angel Fuentes, Council President
Honorable Sheila Davis, Vice-President
Honorable Christopher Collins
Honorable Nohemi Soria-Perez
Honorable Jannette Ramos
Honorable Falio Leyba-Martinez
Honorable Arthur Barclay

Honorable Victor Carstarphen, Mayor

Daniel S. Blackburn, City Attorney
Howard McCoach, Counsel to Council

Luis Pastoriza, Municipal Clerk

Agenda



CITY COUNCIL AGENDA

MARCH 12TH, 2024 – 5:00 P.M.
CITY COUNCIL CHAMBERS

CALL TO ORDER

FLAG SALUTE

ROLL CALL

STATEMENT OF COMPLIANCE

NOTICE OF MEETING

APPROVAL OF MINUTES

COMMUNICATIONS

Department of Finance

1. Check Registers of the City of Camden for The Period of February 1st, 2024 to February 25th, 2024.
2. Payroll Register Summary for the City of Camden for the Pay Periods of February 2nd, 2024 and February 16th, 2024

PRESENTATIONS

OLD BUSINESS

ORDINANCES – FIRST READING

Office of City Council

1. Ordinance Amending MC-5483, To Be Finally Adopted On March 20, 2024, And MC-5419, Adopted On October 11, 2022 And MC-5384 Adopted On May 10, 2022 Which All Amended Chapter 578 Of The Camden City Code Concerning The Licensing Of Peddlers, Vending Units And Food Trucks To Now Permit Licensed Food Trailers To Operate In The City Of Camden At The Same Locations As Food Trucks

Law Department

2. Ordinance Authorizing The Transfer Of (2) Parcels To The Heart Of Camden (HOC)
3. An Ordinance Authorizing condemnation to acquire certain real property situated in tax Block 331, Lot 53 of the City of Camden

Code Enforcement

4. Ordinance Amending MC-5479, Adopted On December 12, 2023 Establishing Section 450-16, Lead-Based Inspections, To Modify The Fees To Be Charged For Lead Inspections To Now Include The City's Costs Incurred For Utilizing A Certified Lead Evaluation Contractor For Such Services

Human Services

5. Ordinance Amending Section 562-14 And Section 562-16 Of The Camden Code To Authorize The Private Use Of City Facilities And Increasing Fees For The Use Of Such Facilities

Planning & Development

6. Ordinance Amending And Supplementing MC-3475, Adopted On May 13, 1999, Governing Previous Section 451-2 Which is Currently Located And Listed As Section 656-2 Of the Camden Code Of The City of Camden Concerning The Appointment Of Members Of The Camden Rooming And Boarding House Site Licensing Board

Public Works

7. An Ordinance Designating Restricted Residential Parking Zones For Individuals With Disabilities To Certain Areas In The City Of Camden As Handicap Parking Privileges Only
8. Ordinance Authorizing The Removal Of Designated Residential Parking Zones For Individuals With Disabilities In Certain Locations

ORDINANCES – SECOND READING & PUBLIC HEARING

Planning & Development

1. Ordinance Establishing the relocation of a bus stop and the removal of two (2) bus stops along Broadway and Atlantic Avenue
2. Ordinance Amending Section 870-230R Of The Camden Code Allowing For The Waiver Of The Cash Contribution Requirement As Approved By The Zoning Officer And Also Amending Section 870-268C Of The Camden Code Requiring That The Submission Of All Applications Under This Section Are To Also Take Place Through Electronic Submission

3. Ordinance Amending And Supplementing Ordinance 717, Adopted December 27, 1945, For The Regulation Of Vehicles And Pedestrians In The Streets Of The City Of Camden And The Enforcement Thereof, For The Purpose Of Installing Two Additional Stop Signs At The East And West Approaches Of The Intersection At Twenty-Ninth And Cramer Streets In Order To Make The Intersection A Four-Way Stop Controlled Intersection

Public Works

4. An Ordinance Designating Restricted Residential Parking Zones For Individuals With Disabilities To Certain Areas In The City Of Camden As Handicap Parking Privileges Only
5. Ordinance Authorizing the Removal of Designated Residential Parking Zones For Individual With Disabilities In Certain Locations

PUBLIC COMMENT

***Public comment for resolutions and/or any other concerns
(Limited to 3 continuous minutes)**

RESOLUTIONS

City Council

1. Resolution Designating Darryl Searles As The City Of Camden Employee Of The Month For March 2024
2. Resolution Recognizing Girl Scout Week 2024
3. Resolution Appointing Arthur Barclay To The Board Of The Camden Special Services District, Inc. A Nonprofit Corporation, Assigned As The District Management Corporation For The Camden Business Improvement District
4. Resolution Appointing Perry Jenkins III To The Anti-Bullying Advisory Board To Perform The Duties As Provided For In Chapter 283, As Established By MC-5392, Adopted On July 12, 2022, And As Amended By MC-5405, Adopted On September 13, 2022
5. Resolution Appointing Nyree Reid To The Anti-Bullying Advisory Board To Perform The Duties As Provided For In Chapter 283, As Established By MC-5392, Adopted On July 12, 2022, And As Amended By MC-5405, Adopted On September 13, 2022
6. Resolution Appointing Martina Godbolt To The Anti-Bullying Advisory Board To Perform The Duties As Provided For In Chapter 283, As Established By MC-5392, Adopted On July 12, 2022, And As Amended By MC-5405, Adopted On September 13, 2022

7. Resolution Appointing Patrice Bassett To The Position Of Deputy Municipal Clerk For A Term Of Three (3) Years
8. Resolution recognizing Rose Giuffre on her 100th birthday

Law Department

9. Resolution Authorizing a Closed Session of the governing body to Discuss Pending Litigation
10. Resolution Authorizing the Settlement of Litigation
11. Resolution Authorizing A Fiscal Year 2024 Tax Agreement Between The City Of Camden And South Jersey Port Corporation

Department of Administration

12. Resolution Authorizing And Ratifying Emergency Procurement And Payment Of Same To The Original W. Hargrove For The Emergency Demolition of 1169 Carl Miller Blvd, Block 453, Lot 131 And Imposing A Municipal Lien Against The Property
13. Resolution authorizing the City to receive proposals for consulting services for a street light audit
14. Resolution Authorizing The City Of Camden To Receive Proposals For Operation And Management Or Administration Of Social Service Facilities Or Programs
15. Resolution Authorizing The City Receive Proposals For Consulting Services And Oversight Of The Emergency Solutions Grant Program
16. Resolution Authorizing The City To Receive Proposals For Grant Writing Services
17. Resolution Authorizing Renting Vehicles from Hertz Corporation Via NJ State Cooperative
18. Resolution Authorizing A Contract With MM SJ Vending LLC To Provide Vending Machine Services For Various City Properties
19. Resolution Authorizing The City Of Camden To Receive Proposals For Consulting Services For Five Year Consolidated Plan, One Year Action Plan And Comprehensive Annual Performance Evaluation Report
20. Resolution Authorizing RFP Solutions, Inc. To Install Cable And Telephone Wiring At Three Community Centers Via County Cooperative

21. Resolution Awarding A Contract For Extraordinary, Unspecifiable Services With DiLorenzo Davis Consulting, LLC and The Latin American Economic Development Association, Inc. For The Buy Camden First Initiative In The Amount Not To Exceed \$185,313.50 with the use of American Rescue Plan State Local Fiscal Recovery Funds
22. Resolution Authorizing The Submission Of An Application To New Jersey Department Of Community Affairs Local Recreational Improvement 2024 Program
23. Resolution Introducing and Approving the 2024 Budget for Camden Special Services District
24. Resolution Authorizing And Ratifying Emergency Procurement And Payment Of Same To The Original W. Hargrove Demolition Co. For the Emergency Demolition of 1437 Belleview Avenue, Block 1274, Lot 98 And Imposing A Municipal Lien Against The Property
25. Resolution Authorizing And Ratifying Emergency Procurement And Payment Of Same To The Original W Hargrove Demolition Co. Inc. For The Emergency Demolition of 112 N 21st Street, Block 1147, Lot 7 And Imposing A Municipal Lien Against The Property
26. Resolution Authorizing And Ratifying Emergency Procurement And Payment Of Same To Winzinger, Inc. For 246-252 Line Street, Block 226, Lot 28 And Imposing A Municipal Lien Against The Property
27. Resolution Amending A Shared Services Agreement Between The City And The Camden County Improvement Authority To Provide For Reimbursement Of Emergency Demolition Costs

Department of Finance

28. Resolution Determining The Form And Other Details Of \$2,000,000 General Improvement Bonds, Series 2024, Of The City Of Camden, In The County Of Camden, New Jersey, And Providing For Their Sale
29. Resolution Authorizing The Cancellation Of Liens/Taxes And To Transfer Credits To Various Lien Holders, Property Owners And Mortgage Companies For Various Properties
30. Resolution Authorizing Refunds To Various Lien Holders, Property Owners And Mortgage Companies For Various Properties And Issuance of Duplicate Tax Certificates

Code Enforcement

31. Resolution Authorizing The Reimbursement Of A Construction Permit Fee To DeVito's HVAC, In The Amount Of \$860.00
32. Resolution Authorizing Pennsauken Animal Hospital To Provide As Needed Veterinary Services For The Care Of Wounded Stray Animals Impounded Throughout The City Of Camden During Normal Business Hours

Office of City Clerk

33. Resolution to extend the time to utilize funds in the amount of \$4500.00 received from the Camden County Cultural and Heritage Commission for the completion of the Historic Mural/website Spanish translations

Planning & Development

34. Resolution Authorizing An Application For Funding from the Urban Enterprise Zone Authority in an amount up to \$326,249.00 For the 2025 Fiscal year Program Budget
35. Resolution Approving A License Agreement Between The City Of Camden And Ryad A. Hassan, 835 N. 7th Street For The Enclosure Extension In The Right Of Way
36. Resolution authorizing a contract to (TBD) for event coordinator (by title)
37. Resolution authorizing the amendment of the USEPA Brownfields Clean-up revolving loan fund sub-grant agreement between the City of Camden and the City of Camden Redevelopment Agency respecting the reliable tire site

Public Works

38. Resolution Authorizing The Continued Rental Of One (1) rear Loader From Big Truck Rental
39. Resolution authorizing a contract under New Jersey State Contract #88679 to EB Fence Limited Liability Co

Fire Department

40. Resolution Authorizing The Purchase Of Fire Hoses From Firefighter 1 through New Jersey State Co-operative

Communications



DEPARTMENT OF FINANCE
CITY OF CAMDEN
NEW JERSEY

VICTOR CARSTARPHEN
MAYOR

0-1
GERALD C. SENESKI
DIRECTOR OF FINANCE
TEL: 856-757-7582
EMAIL: FINANCE@CI.CAMDEN.NJ.US
WEBSITE: WWW.CI.CAMDEN.NJ.US

MEMORANDUM

To: Honorable Angel Fuentes, City Council President
Luis Pastoriza, Municipal Clerk

From: Gerald C. Seneski, Chief Financial Officer 

Date: February 26, 2024

Subject: **Check Register-Communications for Forthcoming City Council Meeting- March 12 ,2024**

Attached, please find the Check Register for the City of Camden for the period of February 1 ,2024 to February 25, 2024 . .

The Check Register represents the checks written from various funds of the City.

Please include this communication in the Agenda for the forthcoming Council Meeting to be voted on for approval.

Please contact me at extension 7582, if you have any additional questions.

GCS/mr

Attachments

cc: Honorable Victor Carstarphen, Mayor

Range of Checking Accts: First to Last Range of Check Dates: 02/01/24 to 02/25/24
Report Type: All Checks Report Format: Super Condensed Check Type: Computer: Y Manual: Y Dir Deposit: Y

Check #	Check Date	Vendor	Amount Paid	Reconciled/Void	Ref Num
TD 01-GENERAL General Account 4308903487					
142840	02/02/24	AXI01 AXIS DEFENSE GROUP, LLC.	2,444.63	20905	Direct Deposit
142841	02/02/24	BIF01 BIFF DUNCAN ASSOCIATES, INC.	1,161.10	20905	Direct Deposit
142842	02/02/24	BO015 BOOMERANG USA INC	1,197.00	20905	Direct Deposit
142843	02/02/24	BOW15 BOWMAN INSPECTION LLC	1,500.00	20905	Direct Deposit
142844	02/02/24	COM6224 COMCAST #6624 ISABEL MILLER	167.89	20905	Direct Deposit
142845	02/02/24	COM6404 COMCAST #6404 CRAMER HILL	252.78	20905	Direct Deposit
142846	02/02/24	COM7634 COMCAST #7634 BROADWAY COMM	156.85	20905	Direct Deposit
142847	02/02/24	COM7905 COMCAST #7905 ENGINE 11 FIRE	127.89	20905	Direct Deposit
142848	02/02/24	COM9777 COMCAST #9777 FLEET	157.89	20905	Direct Deposit
142849	02/02/24	COR36 CORE MECHANICAL, INC.	10,935.87	20905	Direct Deposit
142850	02/02/24	HOM11 HOME DEPOT	177.56	20905	Direct Deposit
142851	02/02/24	HOM15 HOMEWARD BOUND PET ADOPTION	49,166.67	20905	Direct Deposit
142852	02/02/24	MCC44 HOWARD MCCOACH,PC	4,496.80	20905	Direct Deposit
142853	02/02/24	MON41 JP MONZO MUNICIPAL CONSULTING	100.00	20905	Direct Deposit
142854	02/02/24	REM02 REMINGTON & VERNICK ENGINEERS	381,108.10	20905	Direct Deposit
142855	02/02/24	WBM01 W B MASON CO, INC	8,229.50	20905	Direct Deposit
142856	02/02/24	AA02 A & A GLASS	285.00	20908	
142857	02/02/24	AUB01 THE AUBREY GROUP, LLC	1,618.66	20908	
142858	02/02/24	BAR36 AGOSTINO A BARBETTA JR	109.60	20908	
142859	02/02/24	CAR01 CARTUN HARDWARE	191.09	20908	
142860	02/02/24	CCM01 C C M U A	87,142.29	20908	
142861	02/02/24	CME01 CME ASSOCIATES	7,136.10	20908	
142862	02/02/24	COU11 GANNET MEDIA CORP	196.56	20908	
142863	02/02/24	CWA01 CWA LOCAL 1014	11,205.00	20908	
142864	02/02/24	DIV04 DIVISION OF FIRE SAFETY	100.00	20908	
142865	02/02/24	GOV11 GOVERNMENT FINANCE OFFICERS	100.00	20908	
142866	02/02/24	HAR04 THE ORIGINAL W. HARGROVE	10,680.00	20908	
142867	02/02/24	INT14 INTERNATIONAL ASSOC. OF FIRE-	552.26	20908	
142868	02/02/24	INT15 INTERNATIONAL ASSOC OF FIRE-	1,385.86	20908	
142869	02/02/24	IPD01 INSTITUTE FOR PROFESSIONAL DEV	50.00	20908	
142870	02/02/24	JAY02 JAY'S TIRE SERVICE LLC	931.55	20908	
142871	02/02/24	JJM01 JJM PLUMBING COMPANY	5,673.00	20908	
142872	02/02/24	LAU01 LAUREL LAWN MOWER SERVICE	384.00	20908	
142873	02/02/24	LEX02 LEXA CONCRETE LLC	113,243.74	20908	
142874	02/02/24	LOG01 ANTHONY J LOGANDRO	96.00	20908	
142875	02/02/24	MAJ02 MAJESTIC OIL CO, INC	9,676.09	20908	
142876	02/02/24	MUN36 MUNICIPAL EMERGENCY SERVICES	202.00	20908	
142877	02/02/24	NAT52 NATIONAL PAVING CO, INC	5,386.65	20908	
142878	02/02/24	NEW49 NEW LIFE COMMUNITY DEV. CORP	6,600.00	20908	
142879	02/02/24	NJA06 NEW JERSEY AMERICAN WATER CO	242.71	20908	
142880	02/02/24	ORP01 ORPICAL GROUP	2,600.00	20908	
142881	02/02/24	PAC07 PACER SERVICE CENTER	36.30	20908	
142882	02/02/24	PEN07 PENNSAUKEN ANIMAL HOSPITAL	2,234.87	20908	
142883	02/02/24	PIE12 PIETRAGALLO GORDON ALFANO &	12,578.29	20908	
142884	02/02/24	PSE01 PSEG	14,245.89	02/02/24 VOID	20908 (Reason: Needs 2 separate cks)
142885	02/02/24	REA11 REALAUCTION.COM, LLC	44,850.00	20908	
142886	02/02/24	SOU24 SOUTHSTATE, INC.	293,131.93	20908	
142887	02/02/24	STA99 STAPLES ADVANTAGE	56.00	20908	
142888	02/02/24	TRI39 TRI COUNTY TERMITE & PEST	600.95	20908	

Check #	Check Date	Vendor	Amount Paid	Reconciled/Void Ref Num
TD 01-GENERAL		General Account 4308903487		Continued
142889	02/02/24	WAL23 DUANE WALLACE	6,000.00	20908
142890	02/02/24	WES06 WEST MARINE PRODUCTS, INC.	912.58	20908
142891	02/02/24	PSE01 PSEG	1,460.28	20910
142892	02/02/24	PSE01 PSEG	12,785.61	20910
142893	02/06/24	PEN41 DENNIS PENN	989.40	20801
142953	02/06/24	CAM07 CAMDEN BOARD OF EDUCATION	3,708,347.00	20926
142894	02/07/24	CCM01 C C M U A	27,094.34	20543
142895	02/09/24	CWA01 CWA LOCAL 1014	0.00	20920
142896	02/09/24	ANC18 Anchor IT Integrators LLC	5,000.00	20921 Direct Deposit
142897	02/09/24	AXI01 AXIS DEFENSE GROUP, LLC.	1,898.07	20921 Direct Deposit
142898	02/09/24	BOR22 BORTEK INDUSTRIES INC	306,824.00	20921 Direct Deposit
142899	02/09/24	CAM46 CAMDEN REDEVELOPMENT AGENCY	1,005.00	20921 Direct Deposit
142900	02/09/24	CAN12 CANON SOLUTIONS AMERICA, INC	410.19	20921 Direct Deposit
142901	02/09/24	COM1148 Comcast #1148 Public Works	272.89	20921 Direct Deposit
142902	02/09/24	COM7626 COMCAST #7626 KAIGH AVE FIRE	127.89	20921 Direct Deposit
142903	02/09/24	COM7997 COMCAST #7997 FIRE ADMIN.	257.89	20921 Direct Deposit
142904	02/09/24	COM8038 COMCAST #8038 PARK & OPEN SPAC	127.89	20921 Direct Deposit
142905	02/09/24	DEC01 DECOTIIS, FITZPATRICK & COLE	5,655.00	20921 Direct Deposit
142906	02/09/24	DSE01 DIVAL SAFETY EQUIPMENT	3,665.20	20921 Direct Deposit
142907	02/09/24	DUA01 DUANE MORRIS, LLP	981.33	20921 Direct Deposit
142908	02/09/24	ENG01 ENGINEERING HYDRAULICS	605.95	20921 Direct Deposit
142909	02/09/24	REG02 REGINE A ERVIN, CCR	2,892.93	20921 Direct Deposit
142910	02/09/24	REM02 REMINGTON & VERNICK ENGINEERS	126,504.27	20921 Direct Deposit
142911	02/09/24	RIN04 RING CENTRAL	13,726.58	20921 Direct Deposit
142912	02/09/24	SEAS005 SEASIDE WASTE SEVICES	190,000.00	20921 Direct Deposit
142913	02/09/24	SEN04 GERALD SENESKI	923.40	20921 Direct Deposit
142914	02/09/24	SOU65 SOUTH JERSEY SOLUTIONS, LLC	78,995.97	20921 Direct Deposit
142915	02/09/24	WBM01 W B MASON CO, INC	2,558.25	20921 Direct Deposit
142916	02/09/24	WIN02 WINZINGER, INC	119,617.68	20921 Direct Deposit
142917	02/09/24	ASP11 ASPIRE TECHNOLOGY, LLC	838,709.82	20923
142918	02/09/24	BAI11 BAINS DELI LLC - FRANCO PAN	1,493.15	20923
142919	02/09/24	BER01 BERBEN INSIGNIA, CO.	122.00	20923
142920	02/09/24	BUS18 BUSINESS INFORMATION SYSTEMS	2,925.00	20923
142921	02/09/24	CAM12 CAMDEN COUNTY CLERK'S OFFICE	51.00	20923
142922	02/09/24	CAR01 CARTUN HARDWARE	59.09	20923
142923	02/09/24	CAR72 CARMA/NJ	50.00	20923
142924	02/09/24	CDW01 CDWG	777.06	20923
142925	02/09/24	CUN06 TIMOTHY CUNNINGHAM	267.00	20923
142926	02/09/24	DMO01 DMO PRODUCTIONS	500.00	20923
142927	02/09/24	EDM03 Edmunds GovTech	31,125.00	20923
142928	02/09/24	EPI01 EPICOR SOFTWARE CORP	7,630.63	20923
142929	02/09/24	FON04 FRANKIE FONTANEZ, ESQ	11,666.66	20923
142930	02/09/24	GAN01 GANN LAW BOOKS	2,406.00	20923
142931	02/09/24	GRA53 PETER GRAULICH	136.00	20923
142932	02/09/24	INT14 INTERNATIONAL ASSOC. OF FIRE-	552.26	20923
142933	02/09/24	INT15 INTERNATIONAL ASSOC OF FIRE-	1,521.32	20923
142934	02/09/24	IPD01 INSTITUTE FOR PROFESSIONAL DEV	100.00	20923
142935	02/09/24	LEV01 LEVY CONSTRUCTION CO	127,662.64	20923
142936	02/09/24	MAJ02 MAJESTIC OIL CO, INC	35,717.54	20923
142937	02/09/24	MCC16 MICHAEL MCCORMICK	160.00	20923
142938	02/09/24	MIS01 MILLENNIUM STRATEGIES, LLC	5,500.00	20923
142939	02/09/24	NJD34 NJ DEPT OF COMMUNITY AFFAIRS	19,777.00	20923

Check #	Check Date	Vendor	Amount Paid	Reconciled/Void	Ref Num
TD 01-GENERAL		General Account 4308903487			Continued
142940	02/09/24	OTE02 JUAN B. OTERO	300.00		20923
142941	02/09/24	PAT25 PATRIOT ROOFING INC	810.00		20923
142942	02/09/24	PRI52 PRITCHARD INDUSTRIES, LLC	875.00		20923
142943	02/09/24	PROSH005 PROSHRED SECURITY	444.00		20923
142944	02/09/24	PSE01 PSEG	68,900.64		20923
142945	02/09/24	RIS04 RISING LEADER GLOBAL	106,987.90		20923
142946	02/09/24	RUT31 RUTGERS-PEST MANAGEMENT OFFICE	59.00		20923
142947	02/09/24	THE03 THE TREE HOUSE, INC	276.08		20923
142948	02/09/24	UNI02 A-1 UNIFORM CITY, INC	11,270.25		20923
142949	02/09/24	VIS10 VISUAL SOUND, INC	15,028.48		20923
142950	02/09/24	VIT09 VITAL RECORDS HOLDING, LLC	338.72		20923
142951	02/09/24	WES06 WEST MARINE PRODUCTS, INC.	504.90		20923
142952	02/09/24	WIR03 WIRELESS ELECTRONICS, INC	665.00		20923
142954	02/16/24	BIF01 BIFF DUNCAN ASSOCIATES, INC.	851.05		20933 Direct Deposit
142955	02/16/24	CAM46 CAMDEN REDEVELOPMENT AGENCY	724,593.00		20933 Direct Deposit
142956	02/16/24	COM35 COMCAST BUSINESS SERVICES --	373.33		20933 Direct Deposit
142957	02/16/24	COM3757 COMCAST #3757 MLK JR. COMM.	127.89		20933 Direct Deposit
142958	02/16/24	COM7634 COMCAST #7634 BROADWAY COMM	156.85		20933 Direct Deposit
142959	02/16/24	COM9670 COMCAST #9670 MAYOR'S OFFICE	139.79		20933 Direct Deposit
142960	02/16/24	COR36 CORE MECHANICAL, INC.	1,813.00		20933 Direct Deposit
142961	02/16/24	COV05 COVANTA CAMDEN ENERGY RECOVERY	233,841.00		20933 Direct Deposit
142962	02/16/24	FMP01 FACTORY MOTOR PARTS	0.00	02/16/24 VOID	0
142963	02/16/24	FMP01 FACTORY MOTOR PARTS	0.00	02/16/24 VOID	0
142964	02/16/24	FMP01 FACTORY MOTOR PARTS	3,937.38	02/23/24 VOID	20933 Direct Deposit (Reason: ACH Return)
142965	02/16/24	GAR13 GARDEN STATE MAT RENTAL	123.88		20933 Direct Deposit
142966	02/16/24	LIN18 BLOCK LINE SYSTEMS, INC. DBA	6,996.65		20933 Direct Deposit
142967	02/16/24	MCC46 MCCLOSKEY MECHANICAL	1,413.60		20933 Direct Deposit
142968	02/16/24	POL01 POLLUTION CONTROL FINANCING	30,243.60		20933 Direct Deposit
142969	02/16/24	WBM01 W B MASON CO, INC	510.99		20933 Direct Deposit
142970	02/16/24	TDB03 TD Bank - P Card	551.78		20933 Direct Deposit
142971	02/16/24	AFF04 AFFORDABLE HOUSING	115.00		20934
142972	02/16/24	AND08 DAVID J. ANDERSON, ESQ.	275.01		20934
142973	02/16/24	ATT02 LANGUAGE LINE SERVICES	25.50		20934
142974	02/16/24	ATT07 AT&T	12,117.97		20934
142975	02/16/24	ATT08 A T & T MOBILITY	2,404.86		20934
142976	02/16/24	BEL02 VERIZON	13,124.38		20934
142977	02/16/24	BRT01 BRT TECHNOLOGIES, LLC	3,925.05		20934
142978	02/16/24	CAP12 CAPEHART & SCATCHARD	2,485.55		20934
142979	02/16/24	CAR01 CARTUN HARDWARE	106.44		20934
142980	02/16/24	CDW01 CDWG	3,746.40		20934
142981	02/16/24	CIV02 CIVIL SOLUTIONS	1,731.00		20934
142982	02/16/24	COL82 FORREST N. COLLINS	5,936.40		20934
142983	02/16/24	CPI01 CONCEPT PRINTING	13,055.00		20934
142984	02/16/24	CWA01 CWA LOCAL 1014	900.00		20934
142985	02/16/24	DRI04 DOMINGO RIVERA	659.60		20934
142986	02/16/24	GAL17 DANIEL J. GALASSO	2,077.80		20934
142987	02/16/24	GEN27 GENERAL SPRING & ALIGNMENT SVC	3,434.56		20934
142988	02/16/24	GIN03 CALVIN F GINLACK	494.70		20934
142989	02/16/24	GOV11 GOVERNMENT FINANCE OFFICERS	100.00		20934
142990	02/16/24	HAR04 THE ORIGINAL W. HARGROVE	13,900.00		20934
142991	02/16/24	HER31 HERBERT, ROWLAND & GRUBIC, INC	3,652.00		20934
142992	02/16/24	KLO01 MARGARET KLOTZ	659.60		20934

Check #	Check Date	Vendor	Amount Paid	Reconciled/Void	Ref Num
TD 01-GENERAL		General Account 4308903487			Continued
142993	02/16/24	LEX01 LEXIS NEXIS	875.00		20934
142994	02/16/24	NJP02 NEW JERSEY PLANNING OFFICIALS	370.00		20934
142995	02/16/24	PAR09 PARKSIDE BUS. COMM & PRNERSHP	35,820.55		20934
142996	02/16/24	SAV11 NELSON L. SALVIDGE, JR.	108.00		20934
142997	02/16/24	SHE04 DANIEL SHEPPARD	197.50		20934
142998	02/16/24	SHO02 SHOPRITE	248.13		20934
142999	02/16/24	SOU24 SOUTHSTATE, INC.	216,679.41		20934
143000	02/16/24	SPE31 DANIEL SPEARMAN MUSIC LLC	400.00		20934
143001	02/16/24	SPO08 SPOK	6.73		20934
143002	02/16/24	STA99 STAPLES ADVANTAGE	517.81		20934
143003	02/16/24	VER09 VERIZON SELECT SERVICES, INC.	155.79		20934
143004	02/16/24	WAS01 WASTE MANAGEMENT OF NEW JERESY	28,189.22		20934
143005	02/16/24	WES06 WEST MARINE PRODUCTS, INC.	117.98		20934
143006	02/22/24	MOT03 MOTOROLA INC.	6,390.00		20760
143007	02/23/24	FMP01 FACTORY MOTOR PARTS	0.00	02/23/24 VOID	0
143008	02/23/24	FMP01 FACTORY MOTOR PARTS	0.00	02/23/24 VOID	0
143009	02/23/24	FMP01 FACTORY MOTOR PARTS	3,937.38		20933
143010	02/23/24	AMA07 ASSOC.OF MUN.ASSASSOR'S	155.00		20944
143011	02/23/24	AND01 ANDREW VIOLA, ESQ	500.00		20944
143012	02/23/24	ATT08 A T & T MOBILITY	2,404.86		20944
143013	02/23/24	AUT08 AUTO ZONE INC.	815.90		20944
143014	02/23/24	CAM104 CAMDEN COUNTY EMERGENCY MANGMT	50.00		20944
143015	02/23/24	CAM12 CAMDEN COUNTY CLERK'S OFFICE	1,813.00		20944
143016	02/23/24	CCM01 C C M U A	470.13		20944
143017	02/23/24	COR04 CORELOGIC, INC	2,136.15		20944
143018	02/23/24	COU01 COURIER POST	8,991.41		20944
143019	02/23/24	FED14 FEDEX (OMEGA CORP CTR)	187.25		20944
143020	02/23/24	GULFS005 Gulf Stream TaxGroup	217.00		20944
143021	02/23/24	HAR02 HARRY'S PLUMBING L.L.C.	1,092.50		20944
143022	02/23/24	JAY02 JAY'S TIRE SERVICE LLC	485.00		20944
143023	02/23/24	JOS07 JOSEPH'S HOUSE OF CAMDEN, LLC	4,000.00		20944
143024	02/23/24	KER02 JOHN D. KERNAN DMD PA	52,603.00		20944
143025	02/23/24	MAJ02 MAJESTIC OIL CO, INC	3,779.27		20944
143026	02/23/24	MCC27 KRISDEN M MCCRINK	700.00		20944
143027	02/23/24	MGL02 MGL PRINTING SOLUTIONS	131.00		20944
143028	02/23/24	MIC06 MICROSYSTEMS-NJ.COM LLC	2,200.00		20944
143029	02/23/24	MUN36 MUNICIPAL EMERGENCY SERVICES	396.00		20944
143030	02/23/24	NAP01 NAPA AUTO PARTS	313.20		20944
143031	02/23/24	NAT52 NATIONAL PAVING CO, INC	2,105.19		20944
143032	02/23/24	REP01 REPUBLIC SERVICES	58,382.69		20944
143033	02/23/24	RIV39 RIVERFRONT RECYCLING &	5,303.66		20944
143034	02/23/24	ROC01 ROCHESTER MIDLAND CORP	268.25		20944
143035	02/23/24	SHI03 SHI INTERNATIONAL CORP	9,005.61		20944
143036	02/23/24	THEIN005 THE PHILADELPHIA INQUIRER, LLC	1,139.95		20944
143037	02/23/24	TOS02 TOSHIBA FINANCIAL SERVICES	439.96		20944
143038	02/23/24	TRE08 TREASURER, STATE OF NEW JERSEY	774.00		20944
143039	02/23/24	PSE01 PSEG	26,412.34		20945
143040	02/23/24	PSE01 PSEG	609.70		20946
143041	02/23/24	PSE01 PSEG	31,298.89		20947
143042	02/23/24	SOU24 SOUTHSTATE, INC.	102,925.35		20949
143043	02/23/24	BIF01 BIFF DUNCAN ASSOCIATES, INC.	3,968.00		20952 Direct Deposit
143044	02/23/24	CAN12 CANON SOLUTIONS AMERICA, INC	410.19		20952 Direct Deposit

Check #	Check Date	Vendor	Amount Paid	Reconciled/Void	Ref Num
TD 01-GENERAL General Account 4308903487 Continued					
143045	02/23/24	COM5853 COMCAST #5853 N CAMDEN COMM	257.89		20952 Direct Deposit
143046	02/23/24	COM8493 COMCAST #8493 BROADWAY LIBERTY	157.89		20952 Direct Deposit
143047	02/23/24	COM9812 COMCAST #9812 27 FEDERAL ST	127.89		20952 Direct Deposit
143048	02/23/24	COM9853 COMCAST #9853 MALANDRA HALL	127.89		20952 Direct Deposit
143049	02/23/24	HAL12 HALL FIRE RMS, LLC	1,149.75		20952 Direct Deposit
143050	02/23/24	HOM11 HOME DEPOT	1,219.27		20952 Direct Deposit
143051	02/23/24	HOM17 HOME DEPOT CREDIT SERVICES	9,141.36		20952 Direct Deposit
143052	02/23/24	MCC44 HOWARD MCOACH,PC	13,552.00		20952 Direct Deposit
143053	02/23/24	MON41 JP MONZO MUNICIPAL CONSULTING	50.00		20952 Direct Deposit
143054	02/23/24	RIN04 RING CENTRAL	13,725.50		20952 Direct Deposit
143055	02/23/24	SEAS005 SEASIDE WASTE SEVICES	190,000.00		20952 Direct Deposit
143056	02/23/24	SOU03 SOUTH JERSEY WELDING	315.40		20952 Direct Deposit
143057	02/23/24	SPA04 SPARK ELECTRIC SERVICE, INC	360.00		20952 Direct Deposit
143058	02/23/24	SUBDIS01 SUBURBAN DISPOSAL INC	812,500.00		20952 Direct Deposit
143059	02/23/24	TDK01 TDK SYSTEMS GROUP, INC	379.80		20952 Direct Deposit
143060	02/23/24	WAL23 DUANE WALLACE	2,400.00		20952 Direct Deposit
143061	02/23/24	WBM01 W B MASON CO, INC	653.13		20952 Direct Deposit
143062	02/23/24	WIN02 WINZINGER, INC	176,000.00		20952 Direct Deposit
143063	02/23/24	TDB03 TD Bank - P Card	940.00		20952 Direct Deposit

Checking Account Totals	Paid	Void	Amount Paid	Amount Void
Checks:	146	5	6,373,281.43	14,245.89
Direct Deposit:	72	1	3,552,603.28	3,937.38
Total:	218	6	9,925,884.71	18,183.27

Check #	Check Date	Vendor	Amount Paid	Reconciled/Void	Ref Num
TD HUD CDBG HUD - CDBG 4308903718					
25778	02/02/24	DOW14 DOWD HEATING & AIR	9,675.00	02/12/24	20914
25779	02/02/24	PUB04 PSE&G	6,742.35	02/14/24	20914
25780	02/02/24	TM01 T & M ASSOCIATES	2,295.25	02/14/24	20914
25781	02/07/24	DRE07 DREW & ROGERS INC	274.00		20917 Direct Deposit
25782	02/09/24	WBM01 W B MASON CO, INC	335.22		20932 Direct Deposit
25783	02/16/24	EAS12 EASTSIDE BUILDERS	6,000.00	02/23/24	20936
25784	02/16/24	FIR60 FIREFIGHTER ONE LLC	29,949.60	02/23/24	20936

Checking Account Totals	Paid	Void	Amount Paid	Amount Void
Checks:	5	0	54,662.20	0.00
Direct Deposit:	2	0	609.22	0.00
Total:	7	0	55,271.42	0.00

Check #	Check Date	Vendor	Amount Paid	Reconciled/Void	Ref Num
TD HUD HOME HUD - HOME 4308903643					
13385	02/02/24	NEI03 NEIGHBORHOOD HOUSING SERV OF	1,000.00	02/15/24	20915

Checking Account Totals	Paid	Void	Amount Paid	Amount Void
Checks:	1	0	1,000.00	0.00
Direct Deposit:	0	0	0.00	0.00
Total:	1	0	1,000.00	0.00

Check #	Check Date	Vendor	Amount Paid	Reconciled/Void	Ref Num
TD HUD HOPWA HUD - HOPWA 4308907603					
14741	02/02/24	TAM02 TAMARACK APARTMENTS, LLC	554.00	02/13/24	20916
14743	02/16/24	TAM02 TAMARACK APARTMENTS, LLC	396.00		20937
14742	02/20/24	LEW18 LEWIS INSEPCTIONS	2,472.00		20935 Direct Deposit

Check #	Check Date	Vendor	Amount Paid	Reconciled/Void	Ref Num
TD HUD HOPWA HUD - HOPWA 4308907603 Continued					
Checking Account Totals			<u>Paid</u>	<u>Void</u>	<u>Amount Paid</u>
		Checks:	2	0	950.00
		Direct Deposit:	1	0	2,472.00
		Total:	3	0	3,422.00
TD PAYROLL Payroll 4308903502					
40122	02/01/24	PRG-NJFS NJ FAMILY SUPPORT PROCES	14,997.76		20886
40123	02/02/24	CWA01 CWA LOCAL 1014	5,915.08		20911
40124	02/02/24	CWA01 CWA LOCAL 1014	713.00		20911
40125	02/02/24	PRAFLAC- AFLAC - Georgia / New York	2,032.65		20911
40126	02/02/24	PRAFLACG AFLAC, Georgia	2,524.40		20911
40127	02/02/24	PRAFLACN AFLAC, New York	51.40		20911
40128	02/02/24	PRAFLACX AFLAC	288.95		20911
40129	02/02/24	PRCOLINS Colonial Life Insurance	3,021.70		20911
40130	02/02/24	PRCOLINS Colonial Life Insurance	93.52		20911
40131	02/02/24	PRCOREBR Corebridge Financial (Valic)	21,544.00		20911
40132	02/02/24	PRCWAPAC CWA Political Action Committee	55.00		20911
40133	02/02/24	PRDCRP DCRP	4,002.81	02/06/24 VOID	20911 (Reason: wire pmt)
40134	02/02/24	PRF2578 Local #2578	3,138.39		20911
40135	02/02/24	PRF788 Local #788	5,816.61		20911
40136	02/02/24	PRF788H Local #788	2,685.00		20911
40137	02/02/24	PRG-CCSO CAMDEN COUNTY SHERIFF' OFFICE	41.95		20911
40138	02/02/24	PRG-CECL Cece E Canady, Sr	709.50		20911
40139	02/02/24	PRG-FRNK John H Franklin	970.40		20911
40140	02/02/24	PRG-GRMN Charles Gorman	284.60		20911
40141	02/02/24	PRG-HINE DAWNSHIRR M HINES, SGT	10.00		20911
40142	02/02/24	PRG-ICB Isabel Balboa, Esq	848.50		20911
40143	02/02/24	PRG-LACE DAMON LACEY, SGT AT ARMS	633.58		20911
40144	02/02/24	PRG-NJFS NJ FAMILY SUPPORT PROCES	15,053.35		20911
40145	02/02/24	PRG-TODO FRANK TODORO	189.00		20911
40146	02/02/24	PRGPASCD PA SCDU	266.77		20911
40147	02/02/24	PRGPSCDU PENNSYLVANIA SCDU	200.00		20911
40148	02/02/24	PRMET Metlife	468.35		20911
40149	02/02/24	PRNW Nationwide Retirement Solution	4,911.96		20911
40150	02/02/24	PRCAMDEN City of Camden	89,456.23		20912 Direct Deposit
40151	02/02/24	PRCAMDEN City of Camden	72.00		20912 Direct Deposit
40152	02/06/24	PRCOLINS Colonial Life Insurance	93.52		20913
40153	02/06/24	PRCOLINS Colonial Life Insurance	3,021.70		20913
40154	02/07/24	PER32 SHERIE PERSON	252.00		20918
40155	02/16/24	PR-LPFFA Latino Prof Fire Fighters Assn	500.00		20939
40156	02/16/24	PRAFLAC- AFLAC - Georgia / New York	4,557.05		20939
40157	02/16/24	PRAFLACN AFLAC, New York	97.04		20939
40158	02/16/24	PRAFLACX AFLAC	288.94		20939
40159	02/16/24	PRCOLINS Colonial Life Insurance	3,021.70		20939
40160	02/16/24	PRCOLINX Colonial Life Insurance	93.52		20939
40161	02/16/24	PRCOREBR Corebridge Financial (Valic)	21,644.00		20939
40162	02/16/24	PRCWAPAC CWA Political Action Committee	55.00		20939
40163	02/16/24	PRCWAPRK CWA Local 1014 CWA Parking	713.00		20939
40164	02/16/24	PRCWASPR CWA Local 1014 CWA Supervisors	1,248.20		20939
40165	02/16/24	PRCWASTF CWA Local 1014 CWA Staff	4,118.98		20939
40166	02/16/24	PRCWAXRD CWA Local 1014 CWA X-Guard	570.00		20939
40167	02/16/24	PRF2578 Local #2578	3,138.39		20939
40168	02/16/24	PRF788 Local #788	5,816.61		20939

Check #	Check Date	Vendor	Amount Paid	Reconciled/Void	Ref Num
TD PAYROLL Payroll 4308903502 Continued					
40169	02/16/24	PRF788H Local #788	2,685.00		20939
40170	02/16/24	PRG-CCSO CAMDEN COUNTY SHERIFF' OFFICE	40.10		20939
40171	02/16/24	PRG-CECL Cece E Canady, Sr	685.00		20939
40172	02/16/24	PRG-FRNK John H Franklin	905.40		20939
40173	02/16/24	PRG-GRMN Charles Gorman	297.60		20939
40174	02/16/24	PRG-HINE DAWNSHIRR M HINES, SGT	10.00		20939
40175	02/16/24	PRG-ICB Isabel Balboa, Esq	848.50		20939
40176	02/16/24	PRG-LACE DAMON LACEY, SGT AT ARMS	423.23		20939
40177	02/16/24	PRG-NJFS NJ FAMILY SUPPORT PROCES	14,868.87		20939
40178	02/16/24	PRG-TODO FRANK TODORO	189.00		20939
40179	02/16/24	PRGPASCD PA SCDU	289.85		20939
40180	02/16/24	PRGPSCDU PENNSYLVANIA SCDU	200.00		20939
40181	02/16/24	PRMET Metlife	468.35		20939
40182	02/16/24	PRNW Nationwide Retirement Solution	5,161.96		20939
40183	02/16/24	PRPERS PERS Pension	599.32	02/16/24 VOID	20939 (Reason: is a wire pmt)
40184	02/16/24	PRPFIC Police & Fire Insurance Co.	5,872.01	02/16/24 VOID	20939 (Reason: is a wire pmt)
40185	02/16/24	PRPFRS PFRS Pension	1,813.66	02/21/24 VOID	20939 (Reason: is a wire pmt)
40188	02/16/24	PRPFIC Police & Fire Insurance Co.	5,872.01		20941
40186	02/21/24	PR-BUFF Brotherhood United Fire Fight	1,512.19		20940 Direct Deposit
40187	02/21/24	PRCAMDEN City of Camden	90,827.83		20940 Direct Deposit

Checking Account Totals	Paid	Void	Amount Paid	Amount Void
Checks:	59	4	169,639.94	12,287.80
Direct Deposit:	4	0	181,868.25	0.00
Total:	63	4	351,508.19	12,287.80

TD SEWER CAP Sewer Cap (Water) 4308903560					
81002	02/02/24	APC02 A P CONSTRUCTION INC	1,946,322.85		20906 Direct Deposit
81003	02/09/24	REM02 REMINGTON & VERNICK ENGINEERS	4,505.50		20922 Direct Deposit
81004	02/23/24	APC02 A P CONSTRUCTION INC	792,680.51	02/23/24 VOID	20942 (Reason: Chk prntd wrg side)
81005	02/23/24	APC02 A P CONSTRUCTION INC	792,680.51		20942

Checking Account Totals	Paid	Void	Amount Paid	Amount Void
Checks:	1	1	792,680.51	792,680.51
Direct Deposit:	2	0	1,950,828.35	0.00
Total:	3	1	2,743,508.86	792,680.51

TD T-ESCROW Trust - Escrow 4308903700					
1804	02/23/24	DEM07 DEMBO, BROWN & BURNS LLP	880.00		20948
1805	02/23/24	REM02 REMINGTON & VERNICK ENGINEERS	29,156.38		20951 Direct Deposit

Checking Account Totals	Paid	Void	Amount Paid	Amount Void
Checks:	1	0	880.00	0.00
Direct Deposit:	1	0	29,156.38	0.00
Total:	2	0	30,036.38	0.00

TD T-TAX LIENS Trust - Tax Liens 4308903552					
51863	02/01/24	LN-50204 PRO CAP 8 FBO Firstrust Bank	3,802.77		20904
51864	02/01/24	LN-50204 PRO CAP 8 FBO Firstrust Bank	685.10		20904
51865	02/01/24	LN-50204 PRO CAP 8 FBO Firstrust Bank	5,613.04		20904
51866	02/01/24	LN-50230 FIG NJ19, LLC	10,886.87		20904
51867	02/01/24	LN-50230 FIG NJ19, LLC	6,050.40		20904

Check #	Check Date	Vendor	Amount Paid	Reconciled/Void Ref Num
TD T-TAX LIENS		Trust - Tax Liens 4308903552 Continued		
51868	02/08/24	LN-50190 FIG 20, LLC	325.78	20919
51869	02/08/24	LN-50190 FIG 20, LLC	2,192.63	20919
51870	02/08/24	LN-50190 FIG 20, LLC	2,798.93	20919
51871	02/08/24	LN-50190 FIG 20, LLC	6,549.46	20919
51872	02/08/24	LN-50204 PRO CAP 8 FBO Firstrust Bank	1,746.02	20919
51873	02/08/24	LN-50204 PRO CAP 8 FBO Firstrust Bank	1,101.02	20919
51874	02/08/24	LN-50204 PRO CAP 8 FBO Firstrust Bank	1,634.42	20919
51875	02/08/24	LN-50204 PRO CAP 8 FBO Firstrust Bank	1,290.17	20919
51876	02/08/24	LN-50204 PRO CAP 8 FBO Firstrust Bank	2,850.71	20919
51877	02/08/24	LN-50204 PRO CAP 8 FBO Firstrust Bank	606.47	20919
51878	02/08/24	LN-50204 PRO CAP 8 FBO Firstrust Bank	1,870.91	20919
51879	02/08/24	LN-50204 PRO CAP 8 FBO Firstrust Bank	4,003.89	20919
51880	02/08/24	LN-50204 PRO CAP 8 FBO Firstrust Bank	3,479.70	20919
51881	02/08/24	LN-50204 PRO CAP 8 FBO Firstrust Bank	1,068.47	20919
51882	02/08/24	LN-50204 PRO CAP 8 FBO Firstrust Bank	2,250.55	20919
51883	02/08/24	LN-50204 PRO CAP 8 FBO Firstrust Bank	988.60	20919
51884	02/08/24	LN-50204 PRO CAP 8 FBO Firstrust Bank	606.78	20919
51885	02/08/24	LN-50204 PRO CAP 8 FBO Firstrust Bank	6,877.61	20919
51886	02/08/24	LN-50204 PRO CAP 8 FBO Firstrust Bank	484.85	20919
51887	02/08/24	LN-50230 FIG NJ19, LLC	2,063.16	20919
51888	02/08/24	LN-50245 Epcot MD LLC	3,829.95	20919
51889	02/08/24	LN-50245 Epcot MD LLC	5,460.87	20919
51890	02/21/24	LN-20074 LB-HONEY BADGER,SBMUNI%	3,612.13	20938
51891	02/21/24	LN-40187 TLOA OF NJ LLC	23,507.16	20938
51892	02/21/24	LN-50190 FIG 20, LLC	835.37	20938
51893	02/21/24	LN-50190 FIG 20, LLC	609.50	20938
51894	02/21/24	LN-50190 FIG 20, LLC	1,085.05	20938
51895	02/21/24	LN-50190 FIG 20, LLC	5,702.38	20938
51896	02/21/24	LN-50204 PRO CAP 8 FBO Firstrust Bank	457.15	20938
51897	02/21/24	LN-50204 PRO CAP 8 FBO Firstrust Bank	1,285.80	20938
51898	02/21/24	LN-50204 PRO CAP 8 FBO Firstrust Bank	4,324.71	20938
51899	02/21/24	LN-50204 PRO CAP 8 FBO Firstrust Bank	1,056.63	20938
51900	02/21/24	LN-50204 PRO CAP 8 FBO Firstrust Bank	606.78	20938
51901	02/21/24	LN-50204 PRO CAP 8 FBO Firstrust Bank	2,837.60	20938
51902	02/21/24	LN-50204 PRO CAP 8 FBO Firstrust Bank	1,317.57	20938
51903	02/21/24	LN-50204 PRO CAP 8 FBO Firstrust Bank	606.78	20938
51904	02/21/24	LN-50204 PRO CAP 8 FBO Firstrust Bank	902.56	20938
51905	02/21/24	LN-50204 PRO CAP 8 FBO Firstrust Bank	583.99	20938
51906	02/21/24	LN-50204 PRO CAP 8 FBO Firstrust Bank	2,090.53	20938
51907	02/21/24	LN-50204 PRO CAP 8 FBO Firstrust Bank	1,064.91	20938
51908	02/21/24	LN-50204 PRO CAP 8 FBO Firstrust Bank	1,515.99	20938
51909	02/21/24	LN-50204 PRO CAP 8 FBO Firstrust Bank	395.39	20938
51910	02/21/24	LN-50204 PRO CAP 8 FBO Firstrust Bank	2,002.00	20938
51911	02/21/24	LN-50204 PRO CAP 8 FBO Firstrust Bank	492.68	20938
51912	02/21/24	LN-50204 PRO CAP 8 FBO Firstrust Bank	1,632.11	20938
51913	02/21/24	LN-50204 PRO CAP 8 FBO Firstrust Bank	606.78	20938
51914	02/21/24	LN-50204 PRO CAP 8 FBO Firstrust Bank	992.45	20938
51915	02/21/24	LN-50204 PRO CAP 8 FBO Firstrust Bank	6,111.98	20938
51916	02/21/24	LN-50204 PRO CAP 8 FBO Firstrust Bank	606.78	20938
51917	02/21/24	LN-50204 PRO CAP 8 FBO Firstrust Bank	1,060.47	20938
51918	02/21/24	LN-50204 PRO CAP 8 FBO Firstrust Bank	723.48	20938
51919	02/21/24	LN-50204 PRO CAP 8 FBO Firstrust Bank	2,427.03	20938

Check #	Check Date	Vendor	Amount Paid	Reconciled/Void Ref Num
TD T-TAX LIENS		Trust - Tax Liens 4308903552 Continued		
51920	02/21/24	LN-50204 PRO CAP 8 FBO Firstrust Bank	965.34	20938
51921	02/21/24	LN-50204 PRO CAP 8 FBO Firstrust Bank	1,172.97	20938
51922	02/21/24	LN-50204 PRO CAP 8 FBO Firstrust Bank	1,233.45	20938
51923	02/21/24	LN-50204 PRO CAP 8 FBO Firstrust Bank	599.85	20938
51924	02/21/24	LN-50204 PRO CAP 8 FBO Firstrust Bank	995.29	20938
51925	02/21/24	LN-50204 PRO CAP 8 FBO Firstrust Bank	1,078.02	20938
51926	02/21/24	LN-50204 PRO CAP 8 FBO Firstrust Bank	658.98	20938
51927	02/21/24	LN-50204 PRO CAP 8 FBO Firstrust Bank	2,073.11	20938
51928	02/21/24	LN-50204 PRO CAP 8 FBO Firstrust Bank	1,037.70	20938
51929	02/21/24	LN-50204 PRO CAP 8 FBO Firstrust Bank	1,076.67	20938
51930	02/21/24	LN-50204 PRO CAP 8 FBO Firstrust Bank	663.82	20938
51931	02/21/24	LN-50204 PRO CAP 8 FBO Firstrust Bank	707.47	20938
51932	02/21/24	LN-50204 PRO CAP 8 FBO Firstrust Bank	678.86	20938
51933	02/21/24	LN-50204 PRO CAP 8 FBO Firstrust Bank	581.15	20938
51934	02/21/24	LN-50204 PRO CAP 8 FBO Firstrust Bank	670.40	20938
51935	02/21/24	LN-50204 PRO CAP 8 FBO Firstrust Bank	1,729.46	20938
51936	02/21/24	LN-50204 PRO CAP 8 FBO Firstrust Bank	5,923.26	20938
51937	02/21/24	LN-50204 PRO CAP 8 FBO Firstrust Bank	751.61	20938
51938	02/21/24	LN-50204 PRO CAP 8 FBO Firstrust Bank	6,166.70	20938
51939	02/21/24	LN-50204 PRO CAP 8 FBO Firstrust Bank	3,890.55	20938
51940	02/21/24	LN-50204 PRO CAP 8 FBO Firstrust Bank	3,395.30	20938
51941	02/21/24	LN-50204 PRO CAP 8 FBO Firstrust Bank	13,850.00	20938
51942	02/21/24	LN-50204 PRO CAP 8 FBO Firstrust Bank	2,069.94	20938
51943	02/21/24	LN-50204 PRO CAP 8 FBO Firstrust Bank	7,105.56	20938
51944	02/21/24	LN-50204 PRO CAP 8 FBO Firstrust Bank	6,730.42	20938
51945	02/21/24	LN-50204 PRO CAP 8 FBO Firstrust Bank	506.17	20938
51946	02/21/24	LN-50204 PRO CAP 8 FBO Firstrust Bank	728.30	20938
51947	02/21/24	LN-50204 PRO CAP 8 FBO Firstrust Bank	4,836.12	20938
51948	02/21/24	LN-50204 PRO CAP 8 FBO Firstrust Bank	558.13	20938
51949	02/21/24	LN-50216 Real Portfolio 13, LLC	11,813.94	20938
51950	02/21/24	LN-50230 FIG NJ19, LLC	4,744.48	20938
51951	02/21/24	LN-50230 FIG NJ19, LLC	907.12	20938
51952	02/21/24	LN-50230 FIG NJ19, LLC	605.10	20938
51953	02/21/24	LN-50230 FIG NJ19, LLC	1,431.67	20938
51954	02/21/24	LN-50230 FIG NJ19, LLC	2,701.37	20938
51955	02/21/24	LN-50230 FIG NJ19, LLC	438.35	20938
51956	02/21/24	LN-50230 FIG NJ19, LLC	602.08	20938
51957	02/21/24	LN-50245 Epcot MD LLC	4,020.64	20938
51958	02/21/24	LN-50245 Epcot MD LLC	4,221.68	20938
51959	02/21/24	LN-50245 Epcot MD LLC	2,108.11	20938
51960	02/21/24	LN-50245 Epcot MD LLC	4,706.27	20938
51961	02/23/24	LN-20074 LB-HONEY BADGER,SBMUNTX	43.00	20943
51962	02/23/24	LN-20074 LB-HONEY BADGER,SBMUNTX	4,675.99	20943
51963	02/23/24	LN-50204 PRO CAP 8 FBO Firstrust Bank	1,281.67	20943
51964	02/23/24	LN-50204 PRO CAP 8 FBO Firstrust Bank	455.54	20943
51965	02/23/24	LN-50204 PRO CAP 8 FBO Firstrust Bank	1,306.04	20943
51966	02/23/24	LN-50204 PRO CAP 8 FBO Firstrust Bank	1,990.33	20943
51967	02/23/24	LN-50204 PRO CAP 8 FBO Firstrust Bank	2,444.78	20943
51968	02/23/24	LN-50204 PRO CAP 8 FBO Firstrust Bank	533.87	20943
51969	02/23/24	LN-50204 PRO CAP 8 FBO Firstrust Bank	470.36	20943
51970	02/23/24	LN-50245 Epcot MD LLC	4,264.44	20943

Check #	Check Date	Vendor	Amount Paid	Reconciled/Void	Ref Num
TD T-TAX LIENS Trust - Tax Liens 4308903552 Continued					
Checking Account Totals			<u>Paid</u>	<u>Void</u>	<u>Amount Paid</u> <u>Amount Void</u>
	Checks:		108	0	280,374.30 0.00
	Direct Deposit:		0	0	0.00 0.00
	Total:		108	0	280,374.30 0.00
TD T-TRUST Trust - Other Trust 4308903635					
3601	02/02/24	CON53 CONNER STRONG & BUCKELEW, INC.	12,334.00		20907 Direct Deposit
3602	02/02/24	CON24 CONCENTRA MEDICAL CENTER	2,130.00		20909
3603	02/02/24	DSI02 DSI MEDICAL SERVICES INC.	954.00		20909
3604	02/09/24	NJD20 NJ DEPT OF HLTH & SR SER.	101.40		20924
Checking Account Totals			<u>Paid</u>	<u>Void</u>	<u>Amount Paid</u> <u>Amount Void</u>
	Checks:		3	0	3,185.40 0.00
	Direct Deposit:		1	0	12,334.00 0.00
	Total:		4	0	15,519.40 0.00
TD WATER Water (and Sewer) 4308903560					
8819	02/09/24	MCM03 MCMANIMON & SCOTLAND, LLC	9,123.05		20925
8825	02/23/24	NJA18 NJ AMERICAN WATER CO	268,021.37		20950
Checking Account Totals			<u>Paid</u>	<u>Void</u>	<u>Amount Paid</u> <u>Amount Void</u>
	Checks:		2	0	277,144.42 0.00
	Direct Deposit:		0	0	0.00 0.00
	Total:		2	0	277,144.42 0.00
Report Totals					
	Checks:		328	10	7,953,798.20 819,214.20
	Direct Deposit:		83	1	5,729,871.48 3,937.38
	Total:		411	11	13,683,669.68 823,151.58

Totals by Year-Fund					
Fund Description	Fund	Budget Total	Revenue Total	G/L Total	Total
Current Fund	3-01	1,288,511.37	0.00	0.00	1,288,511.37
Water Operating Fund	3-05	<u>268,021.37</u>	<u>0.00</u>	<u>0.00</u>	<u>268,021.37</u>
Year Total:		1,556,532.74	0.00	0.00	1,556,532.74
Current Fund	4-01	8,260,735.94	217.00	0.00	8,260,952.94
Payroll	4-10	351,508.19	0.00	0.00	351,508.19
Insurance Trusts Fund	4-13	15,418.00	0.00	0.00	15,418.00
Trust - TTL Redemption	4-15	280,374.30	0.00	0.00	280,374.30
Animal Control	4-32	<u>101.40</u>	<u>0.00</u>	<u>0.00</u>	<u>101.40</u>
Year Total:		8,908,137.83	217.00	0.00	8,908,354.83
Water Capital Fund	C-06	9,123.05	0.00	0.00	9,123.05
Sewer Capital Fund	C-08	<u>2,743,508.86</u>	<u>0.00</u>	<u>0.00</u>	<u>2,743,508.86</u>
Year Total:		2,752,631.91	0.00	0.00	2,752,631.91
Federal-State Grant Fund	G-02	376,420.40	0.00	0.00	376,420.40
	H-25	59,693.42	0.00	0.00	59,693.42
Total of All Funds:		<u>13,653,416.30</u>	<u>217.00</u>	<u>0.00</u>	<u>13,653,633.30</u>

Project Description	Project No.	Project Total
CARPENTERS SQUARE II, LLC	0408I855	751.97
Branch Village Assoc Phase IV	0408I858	575.72
KIPP Cooper Lanning @ Sumner	0408I866	392.74
PSE&G New State Street Substat	0408I892	2,619.08
HEMANG PATEL RAJ & AARAV, INC	0408I895	175.24
Camden's Charter School Netwrk	0408I896	856.55
PSE&G Woodlynne Substation	0408I899	610.72
CRAMER HILL FAMILY URBAN RENEW	0408I906	732.33
MATRIX ADMIRAL WILSON DEV	0408I909	4,989.03
PSE&G M&R STATION	0408I910	1,390.72
CP THORN & COPEWOOD, LLC	0408I914	3,319.42
PENNSAUKEN QOZ SELF STORAGE LL	0408I927	2,479.14
1800 DAVIS ASSOC URBAN RENEWAL	0408I934	4,763.89
CAMDEN CHARTER SCHOOL NETWORK	0408I936	322.33
Cooper Lanning Sq Ren School	0408P866	416.25
Camden's Charter School Netwrk	0408P896	555.00
CAMDEN'S CHARTER SCHOOL NETWRK	0408P936	855.00
WALNUT STREET ACQUISITION GRP	0408P952	1,300.00
THE COOPER HEALTH SYSTEM	0408P957	2,051.25
PBCIP	16037	720.00
PATRICK J KELLY DRUMS, INC	16040	160.00
Total of All Projects:		<u>30,036.38</u>



DEPARTMENT OF FINANCE
CITY OF CAMDEN
NEW JERSEY

VICTOR CARSTARPHEN
MAYOR

0-2
GERALD C. SENESKI
DIRECTOR OF FINANCE
TEL: 856-757-7582
EMAIL: FINANCE@CI.CAMDEN.NJ.US
WEBSITE: WWW.CI.CAMDEN.NJ.US

MEMORANDUM

To: Honorable Angel Fuentes, City Council President
Luis Pastoriza, Municipal Clerk

From: Gerald Seneski, Chief Financial Officer 

Date: February 26, 2024

Subject: Payroll Register Summary Communications for Forthcoming City
Council Meeting- February 13, 2024

Attached, please find the Payroll Register Summary for the City of Camden for the pay periods of 2/2/2024 and 2/16/2024 . Detailed information is available upon request to the Mayor's Office.

Please include this communication in the Agenda for the forthcoming Council Meeting to be voted on for approval.

Please contact me at extension 7582, if you have any additional questions.

GCS/mr

Attachments

cc: Honorable Victor Carstarphen, Mayor

Final Totals	622 Checks to be Printed 0 Checks Voided since Last Payroll	622 Regular 0 Regular	0 Vacation 0 Vacation	0 Manual 0 Manual	0 Other 0 Other	0 Interim 0 Interim	0 Overtime 0 Overtime	0 Special 0 Special	0 Adjustment 0 Adjustment
Totals:	This Payroll	YTD Beg	This Payroll	Void	Net	YTD End	This Payroll Direct Deposit		
Regular Pay:	1,545,854.71	3,406,868.32	1,697,806.34	0.00	1,697,806.34	5,104,674.66	Payroll Direct Deposit: 1,006,235.92		
Overtime Pay:	73,220.51	2,919,992.41	1,452,935.66	0.00	1,452,935.66	4,372,928.07	Deduction Direct Deposit: 0.00		
Vacation Pay:	0.00	100,262.36	53,799.23	0.00	53,799.23	154,061.59	Total Direct Deposit: 1,006,235.92		
Holiday Pay:	0.00	46,953.91	23,417.74	0.00	23,417.74	70,371.65			
Sick Pay:	0.00	0.00	0.00	0.00	0.00	0.00			
Special Pay:	0.00	307,998.48	151,171.66	0.00	151,171.66	459,170.14	Code 98 Exempt Fwt Wages: 1,432.54		
Admin Pay:	0.00	134,354.61	67,146.09	0.00	67,146.09	201,500.70	Code 98 Exempt Swt Wages: 853.27		
Comp Pay:	0.00	0.00	0.00	0.00	0.00	0.00	*Code 98 Employees are excluded from the Fwt Wages on this Report.		
Other Pay:	0.00	0.00	0.00	0.00	0.00	0.00			
		3,056.36	1,525.96	0.00	1,525.96	4,582.32			
		14,431.61	7,205.36	0.00	7,205.36	21,636.97			
		17,487.97	8,731.32	0.00	8,731.32	26,219.29			
Total Other Tax:		506,333.65	254,370.94	0.00	254,370.94	760,704.59			
Bef Tax Ded:		240,545.57	101,298.03	0.00	101,298.03	341,843.60			
Aft Tax Ded:		2,089,536.84	1,037,871.33	0.00	1,037,871.33	3,127,408.17			
		100,262.36	53,799.23	0.00	53,799.23	154,061.59	Employer + Employer Soc Sec: 107,598.46		
		46,953.91	23,417.74	0.00	23,417.74	70,371.65	Employee + Employer Med: 46,835.48		
		0.00	0.00	0.00	0.00	0.00	Fwt: 151,171.66		
		0.00	0.00	0.00	0.00	0.00	Total Soc Sec, Med + Fwt: 305,605.60		
		0.00	0.00	0.00	0.00	0.00			
		0.00	0.00	0.00	0.00	0.00			
		0.00	0.00	0.00	0.00	0.00			
Total Other Tax:		0.00	0.00	0.00	0.00	0.00			
Fui:		0.00	0.00	0.00	0.00	0.00			
Employer Liability Earning Codes:		709,734.34	359,842.32	0.00	359,842.32	1,069,576.66	NOTE: Ytd Totals include ALL Employees for the Current Payroll Year.		
Total Employer Liabilities:		856,950.61	437,059.29	0.00	437,059.29	1,294,009.90			
Total Gross + Employer Liabilities:		4,263,818.93	2,134,865.63	0.00	2,134,865.63	6,398,684.56			

Payroll Register Report by Dept Id/Emp Name for Check Date: 02/02/24

Total Deductions and Earnings:

Code Description	Ded Amt	Earn Amt	Void Checks Ded Amt	Earn Amt	Net Totals Ded Amt	Earn Amt
D02 BANKRUPTCY	603.50		0.00		603.50	
E02 SECOND TITLED EMPLOY		5,753.11		0.00		5,753.11
E03 ACTING STATUS		1,481.19		0.00		1,481.19
E06 DOCKING		120.09-		0.00		120.09-
E09 ADJUSTMENT		919.86-		0.00		919.86-
E10 ON CALL		1,000.00		0.00		1,000.00
E13 SUSPENSION		1,543.01-		0.00		1,543.01-
E17 Overtime \$		73,079.78		0.00		73,079.78
GBA G - BANKRUPTCY	848.50		0.00		848.50	
GNA G - GARN CANADY	709.50		0.00		709.50	
GNB G - GARN GROMAN	284.60		0.00		284.60	
GNC G - GARN LACEY	633.58		0.00		633.58	
GND G - GARN HINES	10.00		0.00		10.00	
GNE G - GARN FRANKLIN	970.40		0.00		970.40	
GNF G - GARN TODORO	189.00		0.00		189.00	
GNG G - GARN CC SHERIFF	41.95		0.00		41.95	
GPO G - SUPPORT - NJ/PA	200.00		0.00		200.00	
GPI G - SUPPORT - PA	266.77		0.00		266.77	
GS0 G - SUPPORT - NJ	12,134.81		0.00		12,134.81	
GS1 G - SUPPORT - NJ	746.54		0.00		746.54	
GS2 G - SUPPORT - NJ	1,146.00		0.00		1,146.00	
GS3 G - SUPPORT - NJ	548.00		0.00		548.00	
GS4 G - SUPPORT - NJ	190.00		0.00		190.00	
GS5 G - SUPPORT - NJ	288.00		0.00		288.00	
HEA CH 78 COST SHARE	90,187.23		0.00		90,187.23	
HEB CH 78 COST SHARE BACK ADJUST	731.00-		0.00		731.00-	
IMP IMPUTED INCOME		10,932.80		0.00		10,932.80
PD1 DCRP - PENSION	3,691.59		0.00		3,691.59	
PD2 DCRP - BACK DEDUCTION	311.22		0.00		311.22	
PE1 PERS - PENSION	52,867.57		0.00		52,867.57	
PE2 PERS - BACK DEDUCTIONS	578.64		0.00		578.64	
PE4 PERS - CONTRIBUTORY INSURANCE	3,480.84		0.00		3,480.84	
PE9 PERS - LOAN REPAYMENT	26,180.93		0.00		26,180.93	
PE1 PFRS - PENSION	79,363.81		0.00		79,363.81	
PE2 PFRS - BACK DEDUCTIONS	72.92		0.00		72.92	
PF9 PFRS - LOAN REPAYMENT	26,272.07		0.00		26,272.07	
PTA DEF COMP - NATIONWIDE	4,386.96		0.00		4,386.96	
PTB DEF COMP - NATIONWIDE ROTH	525.00		0.00		525.00	

Payroll Register Report by Dept Id/Emp Name for Check Date: 02/02/24

Code	Description	Liability Amt	Void Amt	Net Amt
PTF	DEF COMP - COREBRIDGE	21,272.08	0.00	21,272.08
PTG	DEF COMP - COREBRIDGE ROTH	271.92	0.00	271.92
PTX	DEF COMP - MET LIFE	468.35	0.00	468.35
S10	AFLAC PRE-TAX	2,032.65	0.00	2,032.65
S22	AFLAC GEORGIA POST-TAX	2,524.40	0.00	2,524.40
S31	AFLAC NY PRE-TAX	8.44	0.00	8.44
S32	AFLAC NY POST-TAX	42.96	0.00	42.96
S81	AFLAC XGRD POST-TAX	288.95	0.00	288.95
S99	AFLAC FSA WAGE WORKS	249.99	0.00	249.99
SC1	SUPP - COLONIAL PRE-TAX	78.84	0.00	78.84
SC2	SUPP - COLONIAL POST-TAX	2,942.86	0.00	2,942.86
SC8	SUPP - COLONIAL X-GUARDS	93.52	0.00	93.52
UC1	DUES - CWA STAFF	4,126.88	0.00	4,126.88
UC2	DUES - CWA X-GRD	540.00	0.00	540.00
UC3	DUES - CWA SUPERVISORS	1,248.20	0.00	1,248.20
UC4	DUES - CWA PAC	55.00	0.00	55.00
UC5	DUES - CWA PARKING DEDUCTION	713.00	0.00	713.00
UF1	DUES - FIRE 2578	3,138.39	0.00	3,138.39
UF2	DUES - FIRE 788	5,816.61	0.00	5,816.61
UF5	DUES - FIRE HOUSE FUND	2,685.00	0.00	2,685.00
Z01	MISC - WAGE GARNISHMENT FEE	72.00	0.00	72.00
		<u>355,668.97</u>	<u>89,663.92</u>	<u>355,668.97</u>
			0.00	
				<u>89,663.92</u>

Employer Liability Codes:

Code Description	Liability Amt	Void Amt	Net Amt
940 HEALTH BENEFIT EMPLOYER	359,842.32	0.00	359,842.32
	<u>359,842.32</u>	<u>0.00</u>	<u>359,842.32</u>

Break Down of Employees Paid:

Total Male:	383
Total Female:	227
Total Unknown:	0
Total Employees:	622

There are NO errors or warnings in this Payroll Register.

Final Totals	643 Checks to be Printed	635 Regular	0 Vacation	3 Manual	0 Other	5 Interim	0 Overtime	0 Special	0 Adjustment
	0 Checks Voided since Last Payroll	0 Regular	0 Vacation	0 Manual	0 Other	0 Interim	0 Overtime	0 Special	0 Adjustment
Totals:	This Payroll	YTD Beg	This Payroll	Void	Net	YTD End	This Payroll Direct Deposit		
Regular Pay:	1,570,325.89	5,104,674.66	1,719,183.67	0.00	1,719,183.67	6,823,858.33	Payroll Direct Deposit:		993,980.47
Overtime Pay:	71,298.92	4,372,928.07	1,467,193.80	0.00	1,467,193.80	5,840,121.87	Deduction Direct Deposit:		0.00
Vacation Pay:	0.00	154,061.59	54,463.68	0.00	54,463.68	208,525.27	Total Direct Deposit:		993,980.47
Holiday Pay:	0.00	70,371.65	23,639.67	0.00	23,639.67	94,011.32			
Sick Pay:	0.00	0.00	0.00	0.00	0.00	0.00			
Special Pay:	0.00	459,170.14	156,206.58	0.00	156,206.58	615,376.72	Code 98 Exempt Fwt Wages:		1,432.54
Admin Pay:	0.00	201,500.70	68,221.32	0.00	68,221.32	269,722.02	Code 98 Exempt Swt Wages:		833.27
Comp Pay:	0.00	0.00	0.00	0.00	0.00	0.00			
Other Pay:	0.00	0.00	0.00	0.00	0.00	0.00			
		4,582.32	1,545.34	0.00	1,545.34	6,127.66	*Code 98 Employees are excluded from the Fwt Wages on this Report.		
		21,636.97	7,296.14	0.00	7,296.14	28,933.11			
Total Other Tax:		26,219.29	8,841.48	0.00	8,841.48	35,060.77			
Bef Tax Ded:		760,704.59	256,764.77	0.00	256,764.77	1,017,469.36			
Aft Tax Ded:		347,494.94	110,749.59	0.00	110,749.59	458,244.53			
Net:		3,127,408.17	1,040,296.58	0.00	1,040,296.58	4,167,704.75			
Employer Liability Totals:		154,061.59	54,463.68	0.00	54,463.68	208,525.27	Employee + Employer Soc Sec:		108,927.36
		70,371.65	23,639.67	0.00	23,639.67	94,011.32	Employee + Employer Med:		47,279.34
		0.00	0.00	0.00	0.00	0.00	Fwt:		156,206.58
		0.00	0.00	0.00	0.00	0.00	Total Soc Sec, Med + Fwt:		312,413.28
		0.00	0.00	0.00	0.00	0.00			
Total Other Tax:		0.00	0.00	0.00	0.00	0.00			
Fut:		0.00	0.00	0.00	0.00	0.00			
Employer Liability Earning Codes:		1,069,576.66	357,703.29	0.00	357,703.29	1,427,279.95	NOTE: Ytd Totals include ALL Employees for the Current Payroll Year.		
Total Employer Liabilities:		1,294,009.90	435,806.64	0.00	435,806.64	1,729,816.54			
Total Gross + Employer Liabilities:		6,398,684.56	2,154,990.31	0.00	2,154,990.31	8,553,674.87			

Total Deductions and Earnings:

Code Description	Ded Amt	Earn Amt	Void Checks Ded Amt	Earn Amt	Net Totals Ded Amt	Earn Amt
E02 SECOND TITLED EMPLOY		5,354.96		0.00		5,354.96
E03 ACTING STATUS		1,040.55		0.00		1,040.55
E06 DOCKING		493.96-		0.00		493.96-
E09 ADJUSTMENT		38.15		0.00		38.15
E10 ON CALL		1,000.00		0.00		1,000.00
E12 SEVERENCE		16,844.38		0.00		16,844.38
E14 AUTO ALLOWANCE		525.00		0.00		525.00
E17 Overtime \$		10,976.01		0.00		10,976.01
E18 Sick Payout		15,097.98		0.00		15,097.98
E19 Vacation Payout		13,498.54		0.00		13,498.54
E20 Comp Payout		8,625.16		0.00		8,625.16
GBA G - BANKRUPTCY	848.50		0.00		848.50	
GNA G - GARN CANADY	685.00		0.00		685.00	
GNB G - GARN GROMAN	297.60		0.00		297.60	
GNC G - GARN LACEY	423.23		0.00		423.23	
GND G - GARN HINES	10.00		0.00		10.00	
GNE G - GARN FRANKLIN	905.40		0.00		905.40	
GNF G - GARN TODORO	189.00		0.00		189.00	
GNG G - GARN CC SHERIFF	40.10		0.00		40.10	
GPO G - SUPPORT - NJ/PA	200.00		0.00		200.00	
GPI G - SUPPORT - PA	289.85		0.00		289.85	
GS0 G - SUPPORT - NJ	12,343.63		0.00		12,343.63	
GS1 G - SUPPORT - NJ	669.74		0.00		669.74	
GS2 G - SUPPORT - NJ	873.00		0.00		873.00	
GS3 G - SUPPORT - NJ	504.50		0.00		504.50	
GS4 G - SUPPORT - NJ	190.00		0.00		190.00	
GS5 G - SUPPORT - NJ	288.00		0.00		288.00	
HEA CH 78 COST SHARE	91,451.16		0.00		91,451.16	
HEB CH 78 COST SHARE BACK ADJUST	691.33-		0.00		691.33-	
HEC ch 78 adj post enrollment		5,052.09		0.00		5,052.09
IMP IMPUTED INCOME		11,259.53		0.00		11,259.53
PD1 DCRP - PENSION	3,724.57		0.00		3,724.57	
PD2 DCRP - BACK DEDUCTION	311.22		0.00		311.22	
PE1 PERS - PENSION	52,716.53		0.00		52,716.53	
PE2 PERS - BACK DEDUCTIONS	578.64		0.00		578.64	
PE3 PERS - ARREARS	430.91		0.00		430.91	
PE4 PERS - CONTRIBUTORY INSURANCE	3,470.78		0.00		3,470.78	
PE5 PERS - INSURANCE ARREARS	168.41		0.00		168.41	

Payroll Register Report by Dept Id/Emp Name for Check Date: 02/16/24

Code	Description	Liability Amt	Void Amt	Net Amt
PE9	PERS - LOAN REPAYMENT	26,180.88		26,180.88
PF1	PFRS - PENSION	80,376.46		80,376.46
PF2	PFRS - BACK DEDUCTIONS	72.92		72.92
PF3	PFRS - ARREARS	1,813.66		1,813.66
PF9	PFRS - LOAN REPAYMENT	26,272.07		26,272.07
PTA	DEF COMP - NATIONWIDE	4,436.96		4,436.96
PTB	DEF COMP - NATIONWIDE ROTH	725.00		725.00
PTF	DEF COMP - COREBRIDGE	21,372.08		21,372.08
PTG	DEF COMP - COREBRIDGE ROTH	271.92		271.92
PTK	DEF COMP - MET LIFE	468.35		468.35
S10	AFLAC PRE-TAX	2,032.65		2,032.65
S22	AFLAC GEORGIA POST-TAX	2,524.40		2,524.40
S31	AFLAC NY PRE-TAX	54.08		54.08
S32	AFLAC NY POST-TAX	42.96		42.96
S81	AFLAC XGRD POST-TAX	288.94		288.94
S99	AFLAC FSA WAGE WORKS	249.99		249.99
SC1	SUPP - COLONIAL PRE-TAX	78.84		78.84
SC2	SUPP - COLONIAL POST-TAX	2,942.86		2,942.86
SC8	SUPP - COLONIAL X-GUARDS	93.52		93.52
SF1	SUPP - FIRE INSURANCE	5,872.01		5,872.01
UC1	DUES - CWA STAFF	4,118.98		4,118.98
UC2	DUES - CWA X-GRD	570.00		570.00
UC3	DUES - CWA SUPERVISORS	1,248.20		1,248.20
UC4	DUES - CWA PAC	55.00		55.00
UC5	DUES - CWA PARKING DEDUCTION	713.00		713.00
UF1	DUES - FIRE 2578	3,138.39		3,138.39
UF2	DUES - FIRE 788	5,816.61		5,816.61
UF3	DUES - BUFF	1,512.19		1,512.19
UF4	DUES - LPFFA	500.00		500.00
UF5	DUES - FIRE HOUSE FUND	2,685.00		2,685.00
Z01	MISC - WAGE GARNISHMENT FEE	68.00		68.00
		<u>367,514.36</u>	<u>88,818.39</u>	<u>367,514.36</u>
			0.00	
				<u>88,818.39</u>

Employer Liability Codes:

Code Description	Liability Amt	Void Amt	Net Amt
940 HEALTH BENEFIT EMPLOYER	357,703.29	0.00	357,703.29
	<u>357,703.29</u>	<u>0.00</u>	<u>357,703.29</u>

Break Down of Employees Paid:
 Total Male: 399
 Total Female: 229
 Total Unknown: 0

Total Employees: 640

There are NO errors or warnings in this Payroll Register.

Ordinances 1st
Reading

SORIA-PEREZ
3/12/2024

01

ORDINANCE AMENDING MC-5483, TO BE FINALLY ADOPTED ON MARCH 20, 2024, AND MC-5419, ADOPTED ON OCTOBER 11, 2022 AND MC-5384 ADOPTED ON MAY 10, 2022 WHICH ALL AMENDED CHAPTER 578 OF THE CAMDEN CITY CODE CONCERNING THE LICENSING OF PEDDLERS, VENDING UNITS AND FOOD TRUCKS TO NOW PERMIT LICENSED FOOD TRAILERS TO OPERATE IN THE CITY OF CAMDEN AT THE SAME LOCATIONS AS FOOD TRUCKS

WHEREAS, the City Council of the City of Camden amended Chapter 578 of the Camden City Code through MC-5483, to be finally adopted on March 20, 2024, and MC-5419, adopted on October 11, 2022 and MC-5384, adopted on May 10, 2022, to allow for food trucks to be licensed and operate in certain locations in the City of Camden; and

WHEREAS, the City Council of the City of Camden now seeks to amend MC-5483, to be finally adopted on March 20, 2024, and MC-5419, adopted on October 11, 2022 and MC-5384, adopted on May 10, 2022, to now permit certain food trailers to be licensed and to operate in the City of Camden at the same locations as those allowed for food trucks pursuant to Section 578-16; now therefore

BE IT ORDAINED by the City Council of the City of Camden that MC-5483, to be finally adopted on March 20, 2024, and MC-5419, adopted on October 11, 2022 and MC-5384, adopted on May 10, 2022 which amended Chapter 578 of the Camden City Code is now further amended as follows:

BE IT ORDAINED by the City Council of the City of Camden that Chapter 578 of the City of Camden is amended as follows:

ARTICLE I. Definitions.

578-1. Terms defined.

For the purposes of this chapter, the following additional terms, words and phrases shall have the meanings indicated:

Food Trailer – An enclosed trailer, which is a trailer in which the space between its floor and ceiling is enclosed on all sides by trailer walls, windows and/or doorways, and which is equipped with equipment and facilities as required by the various departments of the City of Camden, including but not limited to, the Fire Department and the Department of Code Enforcement as well as various departments of Camden County, including but not limited to, the Camden County Health Department and the Camden County Police Department, in which such food trailer may include but not be limited to: cookers, grills smokers and other similar equipment for preparing, cooking and then selling various types and forms of food products and beverages, which upon issuance of a license by the City of Camden, may temporarily park upon an approved public street or in an approved public parking lot and engage in the preparation, service, sale or distribution of prepared and other forms of food products and beverages to the general public. A food trailer shall be no more than seven (7) feet wide and no more than fifteen (15) feet long.

ARTICLE II. Licensing.

578-2. Licensing of peddlers, vending units, food trucks and food trailers.

In addition to the provisions of this chapter, Chapter 485 of the City of Camden Code, Licenses and Business Regulations and the Camden County Health Code, if applicable, shall also apply to all peddler licenses, vending unit registrations, food truck and food trailer licenses and all peddlers, vending unit owners and operators, food truck owners and operators and food trailer owners and operators must comply with all of the

provisions of this chapter, chapter 485 and the Camden County Health Code, as applicable.

578-3. License required. Fees.

- A. Same
- B. Same.
- C. No person shall operate or make use of a food truck or food trailer on or over the streets, highways, sidewalks, or public areas unless such food truck or food trailer has been inspected and has been issued a food truck or food trailer license.
- D. Fees. Any person who is not exempt by virtue of N.J.S.A. 45:24-9 et seq., shall be required to pay a licensing fee of \$189.40. All persons who shall be regulated under this chapter shall be required to pay an administrative charge of \$414.00 for each vending unit, food truck or food trailer, as described herein.

578-4. Application.

- A. Peddler's License.
Same.
- B. Vending Unit Registration.
Same.
- C. Food Truck License.
Same.
- D. Food Trailer License. An application for a food truck license shall include:
 - 1. The name, address, telephone number and e-mail address and photograph of the food trailer applicant and whether the applicant is an individual, form or corporation, and if a partnership, the names of the partner, together with their addresses.
 - 2. The name, address, telephone number and e-mail address and photograph of the food trailer operator if different than the owner and whether the operator is an individual, form or corporation, and if a partnership, the names of the partner, together with their addresses.
 - 3. Vehicle information including, a complete description of the Food Trailer, make, model, license plate number, VIN or serial number, insurance policy number, insurance policy coverages and policy limits, a photograph of the trailer and any other documents as determined by the Director.
 - 4. Vehicle information regarding the width and length of the food trailer.
 - 5. Title, bill of sale or any other such proof sufficient to establish lawful ownership of the food trailer to be registered.
 - 6. Driver's license information for the driver of the Truck attached to, towing and/or delivering the food trailer to an approved location as provided for herein.
 - 7. Business records of the Food Trailer company including a New Jersey business registration certificate, articles of incorporation, if any, inspection certificates, if any, Trade Name information, and any other documents as determined by the Director.
 - 8. A valid certificate issued by the Camden County Department of Health and Human Services, pursuant to N.J.A.C. 8:24-9.1.
 - 9. A listing of expected location(s) of operations, a schedule of such operations, including expected days and hours of operation for the Food Trailer.
 - 10. Manufacturer specifications on decibels ranges generated by generators to be used during operations, if any.

11. A map or drawing of the expected location(s) of operation, including the location of all buildings or other structures in the area of proposed operation and the proximity to any adjacent residential areas as well as commercial food service businesses.

12. A description of the method to be used for waste disposal and recycling of materials.

13. Any seating arrangements that will be provided on-site [only when public parking lots are being utilized as the on-site location].

14. Compliance with the State Fire Prevention Code and the State Fire Safety Code, including but not limited to, N.J.A.C. 5:70-2.7(a)(3xii) and N.J.A.C. 5:70-4.7(g) and any other additional fire safety items as required by the Fire Official in his discretion.

15. Any permits as required by the Fire Official, the State Fire Prevention Code and the State Fire Safety Code, including but not limited to, N.J.A.C. 5:70-2.7(a)(3xii) and N.J.A.C. 5:70-4.7(g).

16. Any other documents or other information as determined by the Fire Official, the Director, the Chief License Inspector or the Camden County Health Officer, to carry out the purpose and intent of this chapter, any other provision of the State Fire Prevention Code, the State Fire Safety Code, the City of Camden Code and the Camden County Health Code.

17. An affidavit or certification from the owner/operator that the truck used to tow the food trailer to an approved location as provided for herein, shall remain in close proximity to the trailer during hours that the food trailer is in operation, in case an emergency arises and the trailer must be removed from such location, including but not limited to, police or fire activity or other identified emergency.

578-5. Issuance; contents.

- A. Upon satisfactory completion of all application requirements of this chapter and chapter 485 by Peddlers, Vending Units, Food Trucks and Food Trailers, the Director, when deemed necessary, shall then seek input from the Camden County Police Chief or his designee in determining whether the issuance of such license will infringe upon the public health, safety or welfare of the residents and pedestrians of the City of Camden. In rendering a decision as to whether a license shall be issued, the Director shall also consider and give preference to those applicants with ties to the City of Camden, including whether an applicant is a Camden-owned Business or is a certified New Jersey MBE, WBE, DVBE, VBE or SBE. The Director, in determining whether a food truck or food trailer license is to be permitted for a certain location, shall also consider and take into account whether the overall length and overall width of a food truck or food trailer are appropriate for that specific location. Such a determination by the Director shall be in his sole discretion. Thereafter, the Director shall immediately issue a temporary license, valid for 30 days, which temporary license may be revoked in the event that all requirements of the licensing ordinances of the City of Camden are not met. However, after the application of the above preference, if the number of applicants for a Vending Unit, Food Truck or Food Trailer license or licenses remaining is greater than the remaining number of licenses available from the City of Camden, the City shall conduct a lottery among the remaining eligible license applicants in awarding such license or licenses. Upon the expiration of the temporary license, the applicant shall be issued the appropriate peddler's license, vending unit registration, food truck license or food trailer license authorizing the applicant to conduct the appropriate activities described in the application as approved by the Director.
- B. Same.
- (1) Same.
- (2) Same.

- (3) Same.
- (4) Food Trailer License. A food trailer license shall include the information as specified in section 485-15 of the Camden City Code. A food trailer license shall also include the requirement that a food trailer operating at an approved location shall have the towing truck in close proximity to tow such trailer in case of an emergency pursuant to Section 578-4 herein.

578-6. Display by licensee.

- A. Same.
- B. Same.
- C. Same.
- D. Food Trailer licenses shall be attached to the food trailer in such a way as to be conspicuously displayed to the public during all times of operation.

578-7. Transfer, Assignment and Use.

- A. Same.
- B. Same.
- C. Same.
- D. A Food Trailer license shall not be assignable or transferable and may be used only in the operation of the food trailer as provided for in the license and its application.

578-8. Term; Renewal.

Same.

578-9. Revocation.

- A. The revocation and/or suspension of any license issued hereunder and/or the termination of any vending unit registration, food truck or food trailer license shall be effectuated by the procedures set forth in the Administrative Code of the City of Camden, Section 485-19 et seq.
- B. For purposes of the Chapter, any peddler operating or utilizing a vending unit registration or utilizing a food truck or food trailer license in the name of any other person or business shall be deemed to be an employee of said registrant or license holder. In the event that a peddler, vending unit, food truck or food trailer owner or operator whose license is revoked under this Section or Chapter 485 is found by the Director to be an employee, contract peddler, business representative or agent of another person or business entity licensed under this Chapter, the Director shall also revoke the peddler's license of such principal party.

578-10. Hearings and appeals.

Same.

578-11. Changes of Information.

Same.

ARTICLE III. General Regulations.

578-12. Vending unit standards.

Same.

578-13. Location of vending units.

Same.

578.14. Prohibited activities; peddlers, vending units, food trucks and food trailers.

No peddler, vending unit, food truck or food trailer owner or operator shall:

- A. Same.
- B. Place, stack, station or otherwise maintain any goods, wares, merchandise, signs or other items, other than an approved vending unit, food truck or food trailer, on the streets or sidewalks.
- C. Use public litter receptacles for the disposal of business-related trash or recycling of the peddler, vending unit, food truck or food trailer.
- D. Operate a vending unit, food truck or food trailer that is so constructed, loaded or covered as to prevent its driver from having a clear and unobstructed view of all persons and fixtures located in front of such vending unit, food truck or food trailer while being moved or operated.
- E. Leave any vending unit, food truck or food trailer unattended, at any time, on the streets or sidewalks.
- F. Store, place or leave any vending unit, food truck or food trailer overnight on the streets or sidewalks.
- G. Use or operate any excessive lighting, or amplified noisemakers, loudspeakers, public address system, sound amplifier or other similar devices to attract customers or the attention of the public.
- H. Same.
- I. Conduct the business of peddling or operating a vending unit, food truck or food trailer in such a way as to be a public nuisance.
- J. No person shall place a vending unit, food truck, food trailer or any other device designed to secure a vending unit, food truck or food trailer location on City streets, sidewalks or public property between the hours of 12:00 a.m. to 8:00 a.m., nor shall any person camp out or otherwise occupy such space for the purpose of securing a vending unit, food truck or food trailer location on City streets, sidewalks or public property during said hours. Any person who has conducted vending, food truck or food trailer activities at a location on the City streets, sidewalks or public property shall be allotted thirty (30) minutes set-up and thirty (30) minutes breakdown before and after the stated operating hours, provided however, that nothing herein shall authorize the peddler, vending unit, food truck or food trailer to make sales between 12:00 a.m. to 8:00 a.m.
- K. No peddler, vending unit, food truck or food trailer shall impede or obstruct any street, street intersection or crosswalk.
- L. No peddler, vending unit, food truck or food trailer shall impede the ingress or egress of any public or private driveway.
- M. No peddler, vending unit, food truck or food trailer shall obstruct pedestrian space.
- N. No vending unit, food truck or food trailer shall permit litter or garbage arising from their operations.

578-15. Activities; Food trucks and Food trailers

In addition to Section 578-13 above, whose provisions shall also apply to food trucks and food trailers, a food truck or food trailer owner or operator shall:

- A. Operate a food truck or food trailer only within the following time restrictions: Sunday through Saturday, 8:00 a.m. to 12:00 a.m.
- B. Be prohibited from conducting business or operating a food truck or food trailer on private property, without the express consent of the property owner and approval of the City of Camden.
- C. Be prohibited from conducting business or operating a food truck or food trailer within two hundred (200) feet of a brick and mortar restaurant or any other brick and mortar food establishment.
- D. Utilize power sources of the food truck or food trailer that meet all applicable electrical code standards.

- E. Be prohibited from having a food truck or food trailer in motion unless all propane and natural gas tanks are shut off.
- F. Be prohibited from leaving a food truck or food trailer in overnight storage unless all propane and anural gas tanks are shut off.
- G. Ensure all food truck of food trailer operations take place from the side of the food truck or food trailer only.
- H. Ensure that no food truck or food trailer makes use of a drive-through service.
- I. Ensure that the decibel levels for any generator used shall meet the requirements set forth in Section 870-251 of the City of Camden Code.
- J. Ensure that there are two (2) fully functioning fire extinguishers on the food truck or food trailer: one Class K and one Class 2A-10BC.
- K. Ensure that a food truck or food trailer provides a suitably-sized receptacle for waste, which shall be located no more than ten (10) feet from the service window of the food truck or food trailer. The receptacle shall be maintained and regularly emptied.
- L. Ensure that all waste generated by the operations of a food truck or food trailer , including waste from customers and staff, is disposed of at the base of operations of the food truck or food trailer.
- M. Ensure that a food truck or food trailer is responsible for maintaining the premises on which it is operating in a safe and hygienic manner.

578-16. Food truck and Food trailer licenses and locations.

Subject to Section 578-19 below, the City of Camden shall issue no more than a total of sixteen (16) food truck/food trailer licenses during any specific timeframe to operate in the City of Camden. Licensed food trucks or food trailers shall be permitted to operate in the following areas:

1. Camden Business District
2. Areas with High Levels of Pedestrian Traffic:
 - a. Federal Street at 5th Street
 - b. 200 Block of South Broadway
 - c. Park Boulevard between Kaighn Avenue and Baird Boulevard
 - d. Federal Street between 30th and 33rd Streets
 - e. Morgan Boulevard at 9th Street
 - f. Waterfront area, including:
 1. Children's Garden at Three Riverside Drive.
 2. Aquarium Loop Drive.
 3. Cooper's Point Park and State Street; to include 3 Parking Spots.
 - g. 5th Street between Federal Street and Martin Luther King, Jr. Blvd. [in front of the Camden County Hall of Justice]
 - h. Other areas as deemed appropriate by the Director.

The Director shall have the discretion to take into account the proposed location(s) for a food truck or food trailer for operations and its proximity to other vending units, food trucks or food trailers in that area as well as the types of food offered by those vending units, food trucks or food trailers, in determining whether a food truck or food trailer license shall be issued for a specific time and location.

578-17. Applicable Laws.

A peddler, vending unit, food truck and food trailer shall meet all federal and state laws, regulations and Camden County and City of Camden Code provisions, including but not limited to, health, police and fire safety codes.

578-18. Applicability.

Same.

578-19. Special events.

In addition to the licenses issued pursuant to Section 578-16, above, any person satisfying the application requirements of this Chapter may, at the discretion of the Director, be issued a one- to three-day special events peddler's license, vending unit registration, food truck or food trailer license. The Director, in issuing such a license, may establish specific rules or other policies for this licensee that will remain in effect during the term of the issued license. A one-day license shall permit the licensee to conduct the business activities of a peddler, vending unit, food truck or food trailer within the City of Camden according to the provisions of this Chapter and all other applicable provisions of the City of Camden Code. A one-day license period shall extend for a single twenty-four (24) hour period beginning at 12:00 a.m. on the date specified on the license. All provisions of this Chapter shall apply to a one-day licensee.

578-20. Violations and penalties.

Same.

ARTICLE IV. Emergency Restrictions.

578-21. Authority to issue.

The Camden County Police Department, Metro Division, shall have the authority to issue temporary regulations restricting or prohibiting vending units, food trucks or food trailers when an emergency has been declared by the Chief or his designee in the area of Delaware Avenue, south of the light rail line to Clinton Street and the entire length of Harbor Boulevard or other areas as determined by the Police Chief or his designee.

578-22. Applicability.

Such temporary regulation provided for in section 578-21 above, may be issued when the Camden County Police Department, Metro Division determines that an emergency exists due to the size of scheduled events in the Waterfront Entertainment District, restrictions should be placed on vending and food truck activities in the areas described in section 578-21, herein.

578-23. Advance certification required; exception.

- A. Any regulation issued pursuant to this article, with the exception of emergent regulations, shall be filed with the office of the Municipal Clerk three business days prior to its effective date. The regulation shall be accompanied by a certification issued by the police official designated by the appropriate authority in the Police Department to prepare said certification. The certification shall set forth the reasons requiring the imposition of the temporary restrictions.
- B. Where, due to unforeseen circumstances, crowd control issues require the issuance of temporary regulations concerning the need to restrict vending units, food trucks and/or food trailers, the Camden County Police Department, Metro Division, may issue an emergent temporary regulation; provided however, the Camden County Police Department, Metro Division, shall file the temporary regulation and a certification, with the Office of the Municipal Clerk within two (2) business days of the issuance of the regulation. The certification shall set forth the reasons why the situation giving rise to the regulation could not have been anticipated so that the regulation could have been filed in advance of the event.

578-24. Posting of notices.

Same.

578-25. Responsibility of Police Department.

Same.

578-26. Duties and responsibilities.

The Director and the Chief License Inspector of the Department of Code Enforcement shall have all of the duties and responsibilities provided for in Section 485-9 of the Camden City Code to take all actions necessary by law to prosecute all violators of the provisions provided for herein, including but not limited to Section 485-9K of the Camden City Code.

BE IT FURTHER ORDAINED that all ordinances or parts of ordinances inconsistent with the provisions of this ordinance are hereby repealed as to such inconsistency only.

BE IT FURTHER ORDAINED that this ordinance shall take effect twenty (20) days after its final passage and publication as provided by law.

BE IT FURTHER ORDAINED that if any provision of this ordinance is declared invalid, such invalidity shall not affect the other provisions of this ordinance. Furthermore, the other provisions of this ordinance are deemed to be severable and remain in full force and effect.

BE IT FURTHER ORDAINED that pursuant to N.J.S.A. 52:27BBB-23 and N.J.S.A. 40:69A-41, a true copy of this Ordinance shall be forwarded to the Mayor, who shall have ten (10) days from the receipt thereof to approve or veto this Ordinance. Additionally, pursuant to N.J.S.A. 52:27BBB-23, a true copy of this Ordinance shall be forwarded to the State Commissioner of Community Affairs, who shall have ten (10) days from the receipt thereof to veto this Ordinance, and the action by the Commissioner regarding this Ordinance shall supersede any action by the Mayor on the same Ordinance. All notices of approval and/or veto shall be filed in the Office of the Municipal Clerk.

Date of Introduction: March 12, 2024

The above has been reviewed
and approved as to form.

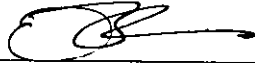

DANIEL S. BLACKBURN
City Attorney

ANGEL FUENTES
President City Council

VICTOR CARSTARPHEN
Mayor

ATTEST: _____
LUIS PASTORIZA
Municipal Clerk

DB:yrh
3-12-24

0-2

**ORDINANCE AUTHORIZING THE TRANSFER OF (2) PARCELS TO
THE HEART OF CAMDEN (HOC)**

WHEREAS, the City of Camden desires to sell these two parcels to the Heart of Camden for the building of two new homes; and

WHEREAS, HOC has requested that it be allowed to purchase two vacant City owned lots for the building of homes on Webster Street and Carl Miller Blvd; and

WHEREAS, the City desires to sell these lots for the agreed assessed amount of Eighteen Thousand Nine hundred Dollars (\$18,900.00) for the two parcels; and

WHEREAS, a municipality is authorized to transfer by ordinance certain real properties to any duly incorporated nonprofit organization for the purpose of building or rehabilitating residential property for resale pursuant to N.J.S.A. 40A: 12-21 (j); and

WHEREAS, the governing body of the City of Camden does hereby authorize the sale of two (2) vacant lots known as 411 Carl Miller Blvd., Block 467, Lots 53 and 410 Webster Street, Block 467 and Lot 20 on the City's Official Tax Map to The Heart of Camden; now, therefore

BE IT ORDAINED, by the City Council of the City of Camden that the proper officer(s) shall be and are hereby authorized to execute the necessary Deed:

SECTION 1. Any portion of this ordinance not herein amended and supplemented shall remain in full force and effect.

SECTION 2. All ordinance or parts of ordinances inconsistent with the provisions of this ordinance are hereby repealed as to such inconsistency only.

SECTION 3. This ordinance shall take effect twenty (20) days after final passage and publications as provided by law.

BE IT FURTHER ORDAINED, that pursuant to N.J.S.A. 52:27BBB-23 and N.J.S.A. 40:69A-41, a true copy of this Ordinance shall be forwarded to the Mayor, who shall have ten (10) days from the receipt thereof to approve or veto this Ordinance. Additionally, pursuant to N.J.S.A. 52:27BBB-23, a true copy of this Ordinance shall be forwarded to the State Commissioner of Community Affairs, who shall have ten (10) days from the receipt thereof to veto this Ordinance, and the action by the Commissioner regarding this Ordinance shall supersede any action by the Mayor on the same Ordinance. All notices of approval and/or veto shall be filed in the Office of the Municipal Clerk.

Date of Introduction: March 12, 2024

The above has been reviewed
and approved as to form.



DANIEL BLACKBURN
City Attorney

ANGEL FUENTES
President, City Council

VICTOR CARSTARPHEN
Mayor

ATTEST:

LUIS PASTORIZA
Municipal Clerk



CITY OF CAMDEN — CITY COUNCIL ACTION REQUEST FORM

COUNCIL MEETING DATE: MARCH 12, 2024

TO: City Council
FROM: Daniel S. Blackburn, City Attorney

TITLE OF ORDINANCE/RESOLUTION: ORDINANCE AUTHORIZING THE TRANSFER OF
(2) PARCELS TO THE HEART OF CAMDEN (HOC)

Point of Contact:	Daniel Blackburn	Law Dept.	X 7170	dablackb@ci.camden.nj.us
	Name	Department-Division-Bureau	Phone	Email

ENDORSEMENTS

	Recommend Approval (Y/N)	Signature	Date	Comments
Responsible				
Department Director				
Supporting Department Director (if necessary)				
Director of Grants Management				
Qualified Purchasing Agent				
Director of Finance				

Approved by:
Business Administrator

Signature	Date
-----------	------

Attachments (list and attach all available):

1. Waiver Request Form Attached for State DCA/DLGS Approval - (If applicable)¹
2. Certification of Funds²
3. Addition supporting documents.

“Walk-on” note: All walk-on legislation must be pre-approved by the Business Administrator. The Department Director and Contact Person are jointly responsible for delivering all necessary documents to the City Clerk for distribution at the Council Meeting.

Received by:
City Attorney

Signature	Date
-----------	------

¹ For Example: Form “A” - Request for approval of Employees Requiring Advice and Consent of Governing Body, Form “D” - Contract Request, Form “E” - Creation/Extension of Services, Form “G” - Grant Approval, Form “H” - Bond Ordinance or Contract Request, Form “I”, “Best Price Insurance Contracting” Model Ordinance

² Mandatory for any financial commitment to the City or expenditure of City Funds.

EXECUTIVE SUMMARY

TITLE OF ORDINANCE/RESOLUTION: ORDINANCE AUTHORIZING THE TRANSFER OF (2) PARCELS TO THE HEART OF CAMDEN (HOC)

FACTS/BACKGROUND: (Executive level details. Short concise bullets)

- The City of Camden is selling these two parcels to a non-profit agency to build two new homes for low to moderate-income families.
- **Time constraints, if any.**
The closing will be held within two weeks of the final City council approval in April 2024.
The purchaser will immediately pull permits and begin the process.
- What legal authorities cover this legislation?

N/A

AMOUNT OF PROPOSED CONTRACT or TOTAL COST OF PROPOSAL:

IMPACT STATEMENT:

- The City will receive compensation of \$18,900
- As part of a negotiation, the City accepted the assessed values for the two lots, which were (\$10,000 and \$8,900)

SUBJECT MATTER EXPERTS/ADVOCATES:

- Yolanda Hawkins, Real Estate Officer

COORDINATION:

Prepared by: Daniel S. Blackburn, City Attorney

X 7170

Name

Phone/Email



OFFICE OF THE CITY ATTORNEY

DANIEL S BLACKBURN
CITY ATTORNEY

VICTOR CARSTARPHEN
MAYOR

CITY OF CAMDEN
NEW JERSEY

TEL: 856757-7170
FAX: 856342-7728

EMAIL: LAW@CI.CAMDEN.NJ.US
WEBSITE: CI.CAMDEN.NJ.US

EXECUTIVE SUMMARY FOR PROPOSED ORDINANCE/RESOLUTION

TITLE OF ORDINANCE/RESOLUTION: ORDINANCE AUTHORIZING THE TRANSFER OF
(2) PARCELS TO THE HEART OF CAMDEN (HOC)

FACTS/BACKGROUND: (Executive level details. Short concise bullets)

- The City of Camden is selling these two parcels to a non-profit agency to build two new homes for low to moderate-income families.
- **Time constraints, if any.**
The closing will be held within two weeks of the final City council approval in April 2024. The purchaser will immediately pull permits and begin the process.
- What legal authorities cover this legislation?
N/A

SUBJECT MATTER EXPERTS/ADVOCATES:

- Yolanda Hawkins, Real Estate Officer

LEGAL ISSUES (if any):

N/A

QUESTIONS & ANSWERS

Q: What will happen if this ordinance/resolution is enacted?

A: **The City will receive compensation of \$18,900**

Q: (For property Ordinances/Resolutions): How was the value of the transaction determined?

A: **As part of a negotiation, the City accepted the assessed values for the two lots, which were (\$10,000 and \$8,900)**

Q: Additional anticipated questions by City Council or Public. . .

N/A

SUITE 419, CITY HALL, P.O. Box 95120, CAMDEN, NEW JERSEY 08101-5120

DSB:dh
03-12-24

0-3

**AN ORDINANCE AUTHORIZING CONDEMNATION
TO ACQUIRE CERTAIN REAL PROPERTY SITUATED IN TAX
BLOCK 331, LOT 53 OF THE CITY OF CAMDEN**

WHEREAS, the "Local Lands and Buildings Law," N.J.S.A. 40A:12-5, provides that a municipality may acquire "any real property ... [b]y purchase, gift, devise, lease, exchange, condemnation, or installment purchase agreement"; and

WHEREAS, the City Council of the City of Camden hereby determines that it is necessary and in the public interest to acquire certain property for the public purpose of remediating environmental contamination; and

WHEREAS, N.J.S.A. 40A:12-1 et seq., the City of Camden is hereby authorized to condemn the real property hereinafter described pursuant to the provisions of the "Eminent Domain Act of 1971," N.J.S.A. 20:3-1 et seq.,

BE IT ORDAINED by the City Council of the City of Camden as follows:

SECTION 1. Pursuant to the provisions of the "Local Lands and Buildings Law," N.J.S.A. 40A:12-1 et seq., the City of Camden is hereby authorized to condemn the real property hereinafter described pursuant to the provisions of the "Eminent Domain Act of 1971," N.J.S.A. 20:3-1 et seq., as follows:

Block 331, Lot 53 on the City of Camden Tax Map, consisting
of approximately 2140 SF, for the public purpose of the
remediating environmental contamination.

SECTION 2. The proper officials or representatives of the City of Camden, are hereby authorized and instructed to negotiate in good faith with the owners(s) of the aforementioned property to seek the voluntary acquisition of this property for its fair market value.

SECTION 3. In event that such negotiations are not successful, the Mayor of the City of Camden or his designees are hereby authorized and instructed to take such actions as may be necessary to acquire the aforementioned property through the exercise of eminent domain as permitted by law.

SECTION 4. The Mayor of the City of Camden or his designees and the Municipal Clerk are hereby authorized and directed to execute such documents and take such actions as may be necessary in order to carry out the purpose and intent of this Ordinance.

SECTION 5. This ordinance shall take effect twenty (20) days after its final passage and publication as provided by law.

BE IT FURTHER ORDAINED, that all ordinances or parts of ordinances inconsistent with the provisions of this ordinance are hereby repealed as to such inconsistency only.

BE IT FURTHER ORDAINED, that pursuant to N.J.S.A. 52:27BBB-23 and N.J.S.A. 40:69A-41, a true copy of this Ordinance shall be forwarded to the Mayor, who shall have ten (10) days from the receipt thereof to approve or veto this Ordinance. Additionally, pursuant to N.J.S.A. 52:27BBB-23, a true copy of this Ordinance shall be forwarded to the State Commissioner of Community Affairs, who shall have ten (10) days from the receipt thereof to veto this Ordinance, and the action by the Commissioner regarding this Ordinance shall supersede any action by the Mayor on the same Ordinance. All notices of approval and/or veto shall be filed in the Office of the Municipal Clerk.

Date of Introduction: March 12, 2024

The above has been reviewed
and approved as to form.



DANIEL S. BLACKBURN
City Attorney

ANGEL FUENTES
President, City Council

VICTOR G. CARSTARPHEN
Mayor

ATTEST: _____
LUIS PASTORIZA
Municipal Clerk



CITY OF CAMDEN — CITY COUNCIL ACTION REQUEST FORM

COUNCIL MEETING DATE: MARCH 12, 2024

TO: City Council
FROM: Daniel S. Blackburn, City Attorney

TITLE OF ORDINANCE/RESOLUTION: AN ORDINANCE AUTHORIZING CONDEMNATION TO ACQUIRE CERTAIN REAL PROPERTY SITUATED IN TAX BLOCK 331, LOT 53 OF THE CITY OF CAMDEN.

Point of Contact:	Michelle Banks-Spearman	Law	X7170	mispearm@ci.camden.nj.us
	Name	Department-Division-Bureau	Phone	Email

ENDORSEMENTS

	Recommend Approval (Y/N)	Signature	Date	Comments
Responsible Department Director Supporting Department Director (if necessary) Director of Grants Management Qualified Purchasing Agent Director of Finance			FEB 29 2024	

Approved by:
Business Administrator

Signature	Date
-----------	------

Attachments (list and attach all available):

1. Waiver Request Form Attached for State DCA/DLGS Approval - (If applicable)¹
2. Certification of Funds²
3. Addition supporting documents.

“Walk-on” note: All walk-on legislation must be pre-approved by the Business Administrator. The Department Director and Contact Person are jointly responsible for delivering all necessary documents to the City Clerk for distribution at the Council Meeting.

Received by:

FEB 29 2024

¹ For Example: Form “A” - Request for approval of Employees Requiring Advice and Consent of Governing Body, Form “D” - Contract Request, Form “E” - Creation/Extension of Services, Form “G” - Grant Approval, Form “H” - Bond Ordinance or Contract Request, Form “I”, “Best Price Insurance Contracting” Model Ordinance

² Mandatory for any financial commitment to the City or expenditure of City Funds.

City Attorney

Signature

Date

EXECUTIVE SUMMARY

TITLE OF ORDINANCE/RESOLUTION: AN ORDINANCE AUTHORIZING CONDEMNATION TO ACQUIRE CERTAIN REAL PROPERTY SITUATED IN TAX BLOCK 331, LOT 53 OF THE CITY OF CAMDEN.

FACTS/BACKGROUND:

- Tax Block 331, Lot 53, also known as 620 Chestnut St., is adjacent to the Weyhill Solid Waste Site located at 619-635 Chestnut, which the City now owns by way of foreclosure.
- 620 Chestnut St. is surrounded by the solid waste site and solid waste has encroached on the yard of 620 Chestnut.
- The City has entered into contracts to remediate the solid waste site and 620 Chestnut. In order to complete the environmental remediation of the solid waste site it is necessary for the City to acquire 620 Chestnut.
- In order for the remediation to be completed before the termination of those contracts it is necessary for the City to acquire 620 Chestnut St. as soon as possible.
- The property will be acquired for its fair market value as determined by an appraisal or by the Condemnation Commissioners.

AMOUNT OF PROPOSED CONTRACT or TOTAL COST OF PROPOSAL: To be determined.

IMPACT STATEMENT:

- The solid waste at 620 Chestnut will not be removed.
- If City Council approves this legislation, the City will be able to complete the remediation on 620 Chestnut St.
- The City will be able to complete the remediation of the Weyhill Solid Waste Site and 620 Chestnut St. and improve the conditions for the residents of the affected neighborhood.
- If City Council does not approve this legislation, the City will not be able to complete the remediation of the Weyhill Solid Waste Site.

SUBJECT MATTER EXPERTS/ADVOCATES:

- Daniel S. Blackburn, Esq.
 - Attendance: (Y). Confirmed? Y
- Michelle Banks-Spearman, Esq.
 - Attendance: (Y). Confirmed? Y
- Olivette Simpson, Interim Executive Director, CRA
 - Attendance: (Y). Confirmed? Y

COORDINATION:

- If this legislation is passed the residents, schools, churches, businesses and other institutions located in the affected neighborhood will benefit from a cleaner environment and the elimination of an eyesore.

Prepared by:

Michelle Banks-Spearman

X7170

mispearm@ci.camden.nj.us

Name

Phone/Email

0-4

DB:HM
03-12-24

ORDINANCE AMENDING MC-5479, ADOPTED ON DECEMBER 12, 2023 ESTABLISHING SECTION 450-16, LEAD-BASED INSPECTIONS, TO MODIFY THE FEES TO BE CHARGED FOR LEAD INSPECTIONS TO NOW INCLUDE THE CITY'S COSTS INCURRED FOR UTILIZING A CERTIFIED LEAD EVALUATION CONTRACTOR FOR SUCH SERVICES

WHEREAS, on December 12, 2023, the City Council of the City of Camden adopted MC-5479, which established Section 450-16; Lead-Based Paint Inspections; and

WHEREAS, Section 450-16.4; Fees for Inspection, failed to take into account the amount of fees that the City of Camden would incur in making use of an outside contractor who is a Certified Lead Evaluation Contractor and who has been procured following a procurement process instituted by the City of Camden to provide such lead-based paint inspection services; and

WHEREAS, the City Council of the City of Camden, now seeks to amend Section 450-16; Fees for Inspection, to include fees charged to the City of Camden by a Certified Lead Evaluation Contractor, for such lead-based paint inspection services; now therefore,

BE IT ORDAINED, by the City Council of the City of Camden that Section 450-16 is amended as follows:

§450-16.4. Fees for Inspection

- (1) The fees incurred by the City of Camden for the use of a Certified Lead Evaluation Contractor who has been procured following a procurement process instituted by the City of Camden to provide such lead-based paint inspection services shall be the responsibility of the owner. All of the fees as provided for in this Section must be paid directly to the City of Camden prior to the lead-based inspection services being provided.
- (2) The fee for a dust wipe sampling inspection shall be based on the City's actual cost incurred and may vary based on the square footage and number of bedrooms in a rental unit.
- (3) There is an additional assessment of \$40.00 per dwelling unit which encompasses fees for the City and the State. This \$40.00 per dwelling assessment includes an assessment pursuant to N.J.S.A 52:27D-437.1 et seq. which requires the assessment of a \$20.00 fee per dwelling unit, for the New Jersey Lead Hazard Control Assistance Fund, unless the owner demonstrates that the New Jersey Department of Community Affairs has already assessed the additional inspection fee of \$20.00. The other \$20.00 of the \$40.00 assessment covers the City's administrative costs associated with the requirements of the lead-based paint inspection law.
- (4) In a common-interest community, any inspection fee charged pursuant to this subsection shall be the responsibility of the unit owner and not the homeowner's association, unless the homeowner's association is the owner of the unit.

BE IT FURTHER ORDAINED that all ordinances or parts of ordinances inconsistent with the provisions of this ordinance are hereby repealed as to such inconsistency only.

BE IT FURTHER ORDAINED that this ordinance shall take effect twenty (20) days after its final passage and publication as provided by law.

BE IT FURTHER ORDAINED that if any provision of this ordinance is declared invalid, such invalidity shall not affect the other provisions of this ordinance. Furthermore, the other provisions of this ordinance are deemed to be severable and remain in full force and effect.

BE IT FURTHER ORDAINED that pursuant to N.J.S.A. 52:27BBB-23 and N.J.S.A. 40:69A-41, a true copy of this Ordinance shall be forwarded to the Mayor, who shall have ten (10) days from the receipt thereof to approve or veto this Ordinance. Additionally, pursuant to N.J.S.A. 52:27BBB-23, a true copy of this Ordinance shall be forwarded to the State Commissioner of Community Affairs, who shall have ten (10) days from the receipt thereof to veto this Ordinance, and the action by the Commissioner regarding this Ordinance shall supersede any action by the Mayor on the same Ordinance. All notices of approval and/or veto shall be filed in the Office of the Municipal Clerk.

Date of Introduction: March 12, 2024

The above has been reviewed
and approved as to form.

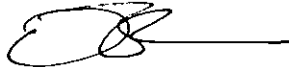

DANIEL S. BLACKBURN
City Attorney

ANGEL FUENTES
President City Council

VICTOR CARSTARPHEN
Mayor

ATTEST: _____
LUIS PASTORIZA
Municipal Clerk

*O-S
revised*

ORDINANCE AMENDING SECTION 562-14 AND SECTION 562-16 OF THE CAMDEN CODE TO AUTHORIZE THE PRIVATE USE OF CITY FACILITIES AND INCREASING FEES FOR THE USE OF SUCH FACILITIES

WHEREAS, the Administration of the City of Camden is now seeking to amend Section 562-14 to authorize and establish the private use of City facilities; and

WHEREAS, , the Administration of the City of Camden is also seeking to amend Section 562-16 of the Camden City Code to increase the fees to be charged for the private use of City facilities; now therefore,

BE IT ORDAINED, by the City Council of the City of Camden that Section 562-14 and Section 562-26 of the Camden City Code are amended as follows:

§ 562-14. Groups to use application to reserve facility.

- A. Any community-oriented organization or group which desires to reserve the use of a City park or ball field must do so by an application to the Department of Human Services. The use of the park or ball field must be directly related to the community-oriented purpose of said organization or group.
- B. Any individual, organization or group which desires to utilize a recreational facility for a private purpose, such as a wedding or anniversary reception, must do so by an application to the Department of Human Services. Private use of City of Camden facilities shall be extended to the following recreational facilities pending approval for use:
 - 1. Cramer Hill Community Center, 1035 Reeves Avenue
 - 2. Malandra Hall Community Center, 1200 S. Merrimac Road
 - 3. Isabel Miller Community Center, Eighth & Carl Miller Blvd.
 - 4. Martin Luther King Community Center, 1151 Haddon Avenue
 - 5. North Camden Gymnasium, 1000 N. Sixth Street
 - 6. Watertower, Rose & Everett Streets
- C. The Department of Human Services shall be the final authority as to whether a proposed use is community-oriented or private in nature. The Department of Human Services shall determine whether the proposed private use is appropriate, pursuant to the standard set forth in § 562-10 of this chapter. The Department of Human Services shall have the right to deny use of a recreational facility if the proposed use is deemed to be inappropriate.

§ 562-16. Application fees for private individuals or groups.

- A. A non-refundable security deposit in the amount of \$150 shall be assessed for each application submitted by an individual or group for private use of a recreational facility. The City of Camden shall be permitted to charge the applicant for the cost for any damage to the facility resulting from the applicant's use of the facility.
- B. The applicant may be required to hire one Camden County police officer and/or a security guard for the duration of the applicant's use of the facility. The police officer must be hired in accordance with the terms of employment, including off-duty employment, established by the Camden County Police Department. The hourly rate and other applicable costs, for such police officer or security guard shall be set by the employer of the Camden County police officer or security guard.
- C. Should the applicant's use of the facility extend beyond the agreed upon number of hours for a specific recreational facility, the applicant shall be required to pay the specified hourly fee for the additional use of that recreational facility, as provided for in section 562-16 E, herein. The applicant shall also be required to pay the hourly rate and other applicable costs, for the additional hours worked by the Camden County police officer, security guard and/or the City of Camden employee when the applicant's use of the facility is beyond any agreed upon number of hours.
- D. All fees shall be due seven days prior to the private use of the facility or the applicant shall be denied access to the facility. Any additional fees assessed related to the additional use of the Camden County police officer, security guard and/or the City

employee, caused by the applicant's continued use of the facility beyond the permitted time-frame, shall be charged to the applicant.

E. Recreational facility rates shall be as follows:

1. Cramer Hill Community Center - \$100.00 per hour and a maximum capacity of 100 people
2. Malandra Hall Community Center - \$150.00 per hour and a maximum capacity of 150 people
3. Isabel Miller Community Center - \$100.00 per hour and a maximum capacity of 75 people
4. Martin Luther King Community Center - \$100.00 per hour and a maximum capacity of 50 people
5. North Camden Gymnasium - \$100.00 per hour and the maximum capacity of people shall be based on the approved activity
6. Watertower, Rose & Everett Streets - \$100 per hour and a maximum capacity of 100 people.

BE IT FURTHER ORDAINED that all ordinances or parts of ordinances inconsistent with the provisions of this ordinance are hereby repealed as to such inconsistency only.

BE IT FURTHER ORDAINED that this ordinance shall take effect twenty (20) days after its final passage and publication as provided by law.

BE IT FURTHER ORDAINED that if any provision of this ordinance is declared invalid, such invalidity shall not affect the other provisions of this ordinance. Furthermore, the other provisions of this ordinance are deemed to be severable and remain in full force and effect.

BE IT FURTHER ORDAINED that pursuant to N.J.S.A. 52:27BBB-23 and N.J.S.A. 40:69A-41, a true copy of this Ordinance shall be forwarded to the Mayor, who shall have ten (10) days from the receipt thereof to approve or veto this Ordinance. Additionally, pursuant to N.J.S.A. 52:27BBB-23, a true copy of this Ordinance shall be forwarded to the State Commissioner of Community Affairs, who shall have ten (10) days from the receipt thereof to veto this Ordinance, and the action by the Commissioner regarding this Ordinance shall supersede any action by the Mayor on the same Ordinance. All notices of approval and/or veto shall be filed in the Office of the Municipal Clerk.

March 12, 2024

The above has been reviewed
and approved as to form.



DANIEL S. BLACKBURN
City Attorney

ANGEL FUENTES
President City Council

VICTOR CARSTARPHEN
Mayor

ATTEST: _____
LUIS PASTORIZA
Municipal Clerk



CITY OF CAMDEN — CITY COUNCIL ACTION REQUEST FORM

COUNCIL MEETING DATE: 3-12-24

TO: City Council
FROM: Dorri Brown, Acting Director, Human Services

TITLE OF ORDINANCE/RESOLUTION: Ordinance editing use of additional community centers for private use.

Point of Contact: Janean Gooden Human Services, 856-968- jagooden@ci.camden.nj.us
Neighborhood Services 6406

ENDORSEMENTS

	Recommend Approval (Y/N)	Signature	Date	Comments
Responsible Department Director	Y	Dorri Brown	2-22-23	
Supporting Department Director (if necessary)	Y			
Director of Grants Management	Y			
Qualified Purchasing Agent				
Director of Finance				

Approved by:
Business Administrator

2-23-24

Signature

Date

Attachments (list and attach all available):

1. Waiver Request Form Attached for State DCA/DLGS Approval - (If applicable)¹
2. Certification of Funds²
3. Addition supporting documents.

"Walk-on" note: All walk-on legislation must be pre-approved by the Business Administrator. The Department Director and Contact Person are jointly responsible for delivering all necessary documents to the City Clerk for distribution at the Council Meeting.

Received by:
City Attorney

FEB 27 2024

Signature

Date

¹ For Example: Form "A" - Request for approval of Employees Requiring Advice and Consent of Governing Body, Form "D" - Contract Request, Form "E" - Creation/Extension of Services, Form "G" - Grant Approval, Form "H" - Bond Ordinance or Contract Request, Form "I", "Best Price Insurance Contracting" Model Ordinance

² Mandatory for any financial commitment to the City or expenditure of City Funds.

EXECUTIVE SUMMARY

TITLE OF ORDINANCE/RESOLUTION: A concise, precise, and complete description of the action the City Council is going to take.

FACTS/BACKGROUND: (Executive level details. Short concise bullets)

- Resolution to amend City Ordinance 562:14 and 562:16 to authorize private use of all city facilities by the Dept. of Human Services, Neighborhood Services.
- Also increasing the rates from \$150 deposit and \$50 per hour use to: \$50 non-refundable fee and hourly use rate of \$100 or \$150 per hour based on the facility.

AMOUNT OF PROPOSED CONTRACT or TOTAL COST OF PROPOSAL: No Cost to City

IMPACT STATEMENT:

- Facility rate have been \$50 per hour since 2012. With newly renovated facilities and to maintain upkeep of facility for years to follow.
- Average rental fees for facility use in and around our area is \$200 plus per hour

SUBJECT MATTER EXPERTS/ADVOCATES:

COORDINATION:

Prepared by: **Janean Gooden**

856-968-6406 jagooden@ci.camden.nj.us

Name

Phone/Email

§ 562-14. Groups to use application to reserve facility.

Latest version.

A.

Any community-oriented organization or group which desires to reserve the use of a City park or recreational facility must do so by an application to the Bureau of Recreation. The use of the park or facility must be directly related to the community-oriented purpose of said organization or group.

B.

Any individual, organization or group which desires to utilize a recreational facility for a private purpose, such as a wedding or anniversary reception, must do so by an application to Bureau of Recreation. Private use of City of Camden facilities shall be limited to the Cramer Hill Community Center.

C.

The Bureau of Recreation shall be the final authority as to whether a proposed use is community-oriented or private in nature. The Bureau shall determine whether the proposed private use is appropriate, pursuant to the standard set forth in § 562-10 of this chapter. The Bureau shall have the right to deny use of a recreational facility if the proposed use is deemed to be inappropriate.

Amended 4-26-2001 by Ord. No. MC-3653

§ 562-14. Groups to use application to reserve facility.

Edit to read

A.

Any community-oriented organization or group which desires to reserve the use of a City park or [REDACTED] must do so by an application to the Bureau of Recreation. The use of the park or [REDACTED] must be directly related to the community-oriented purpose of said organization or group.

B.

Any individual, organization or group which desires to utilize a recreational facility for a private purpose, such as a wedding or anniversary reception, must do so by an application to [REDACTED]

[REDACTED]

[REDACTED]

[REDACTED]

C.

The [REDACTED] shall be the final authority as to whether a proposed use is community-oriented or private in nature. The [REDACTED] shall determine whether the proposed private use is appropriate, pursuant to the standard set forth in § 562-10 of this chapter. The [REDACTED] shall have the right to deny use of a recreational facility if the proposed use is deemed to be inappropriate.

Amended 4-26-2001 by Ord. No. MC-3653

§ 562-16. Application fees for private individuals or groups.

Latest version.

A.

A refundable security deposit in the amount of \$150 is assessed for each application submitted by an individual or group for private use of a recreational facility. The City of Camden will be permitted to deduct the cost of any damage to the facility resulting from the applicant's use of the facility or outstanding fees.

B.

The applicant may be required to hire one City of Camden police officer and/or a security guard for the duration of the applicant's use of the facility. The police officer must be hired in accordance with the terms of § 110-15, Off-duty employment, of the Code of the City of Camden.

[Amended 6-12-2012 by Ord. No. MC-4672]

C.

The applicant will be required to pay a fee of \$50 per hour, for any applicable overtime costs for one City of Camden employee who will be responsible for monitoring the applicant's use of the facility. The applicant shall be required to pay the cost of one full day (seven hours) fee of \$350 should the applicant's use extend past four hours.

[Amended 6-12-2012 by Ord. No. MC-4672]

D.

The fees for the security deposit, City of Camden police officer and employee shall be due seven days prior to the private use of the facility or the applicant will be denied access to the facility. Any additional fees assessed for the police officer and employee, due to an extension past the applicant's estimated duration of use, will be deducted from the security deposit.

Added 4-26-2001 by Ord. No. MC-3653

§ 562-16. Application fees for private individuals or groups.

Edit to read

A.
[REDACTED] is assessed for each application submitted by an individual or group for private use of a recreational facility. The City of Camden will be permitted to [REDACTED] [REDACTED] cost of any damage to the facility resulting from the applicant's use of the facility.

B.
The applicant may be required to hire one City of Camden police officer and/or a security guard for the duration of the applicant's use of the facility. The police officer must be hired in accordance with the terms of § 110-15, Off-duty employment, of the Code of the City of Camden.
[Amended 6-12-2012 by Ord. No. MC-4672]

C.
The applicant will be required to pay a fee [REDACTED], for any applicable overtime costs for one City of Camden employee who will be responsible for monitoring the applicant's use of the facility. The applicant shall be required to pay the cost of one full day (seven hours) fee of [REDACTED] should the applicant's use extend past four hours.
[Amended 6-12-2012 by Ord. No. MC-4672]

D.
[REDACTED]

Added 4-26-2001 by Ord. No. MC-3653

E.
Recreational facility rates are as follows:

[REDACTED]

0-6

DB:HM
03-12-24

ORDINANCE AMENDING AND SUPPLEMENTING MC-3475, ADOPTED ON MAY 13, 1999, GOVERNING PREVIOUS SECTION 451-2 WHICH IS CURRENTLY LOCATED AND LISTED AS SECTION 656-2 OF THE CAMDEN CODE OF THE CITY OF CAMDEN CONCERNING THE APPOINTMENT OF MEMBERS OF THE CAMDEN ROOMING AND BOARDING HOUSE SITE LICENSING BOARD

WHEREAS, on May 13, 1999, the City Council of the City of Camden adopted MC-3475, which amended then Chapter 451, Section 451-2; Establishment of Licensing Board, to add the following:

Section 451-2. Establishment of Licensing Board

The Camden Rooming and Boarding House Site Licensing Board, is hereby established pursuant to the provisions of N.J.S.A. 40: 52-9 et. seq., which shall be the licensing authority for the City of Camden. The Board shall consist of three (3) persons, no more than two (2) of whom may be of the same political party, to be appointed by resolution of the municipal governing body. Members shall serve for terms of three (3) years and until their successors are appointed and qualified into office; except that of the initial three (3) appointments, one (1) shall be for a term of one (1) year and one (1) for a term of two (2) years. Members of the municipal governing body shall be eligible for appointment to the Board. Members of the Board shall receive no salaries, but shall be entitled to reimbursement for actual expenses necessarily incurred in the performance of their duties as such members. There shall be two (2) alternate members to the Board to serve for a term of one (1) year. In the event of vacancies or absences, the alternate members may act in lieu of the regular members provided, however, no alternate member shall participate in Board action if by reason of his or her participation, more than two members of the Board shall be of the same political party. Members may be removed by the appointing authority for cause. They shall not be subject to the provisions of Title 11A, Civil Service, of the New Jersey Statutes; and

WHEREAS, the City Council of the City of Camden now seeks to clarify and expound upon the above language, specifically the term: "to be appointed by resolution of the municipal governing body" to provide that Board Appointees shall initially be recommended by the Mayor to the City Council of the City of Camden who shall then approve such recommendations by resolution of the City Council of the City of Camden; now therefore

BE IT ORDAINED, by the City Council of the City of Camden, that MC-3475, adopted on May 13, 1999, now located and listed as Section 656-2 of the Camden Code is hereby amended as follows:

Section 656-2. Establishment of Licensing Board

The Camden Rooming and Boarding House Site Licensing Board, established pursuant to the provisions of N.J.S.A. 40: 52-9 et. seq., shall be the licensing authority for the City of Camden. The Board shall consist of three (3) persons, no more than two (2) of whom may be of the same political party, who shall be recommended by the Mayor to the City Council of the City of Camden for approval by resolution of the City Council of the City of Camden. Members shall serve for terms of three (3) years and until their successors are appointed and qualified into office; except that of the initial three (3) appointments, one (1) shall be for a term of one (1) year and one (1) for a term of two (2) years. Members of the municipal governing body shall be eligible for appointment to the Board. Members of the Board shall receive no salaries, but shall be entitled to reimbursement for actual expenses necessarily incurred in the performance of their duties as such members. There shall be two (2) alternate members to the Board to serve for a term of one (1) year. In the event of vacancies or

absences, the alternate members may act in lieu of the regular members provided, however, no alternate member shall participate in Board action if by reason of his or her participation, more than two members of the Board shall be of the same political party. Members may be removed by the appointing authority for cause. They shall not be subject to the provisions of Title 11A, Civil Service, of the New Jersey Statutes.

BE IT FURTHER ORDAINED that all ordinances or parts of ordinances inconsistent with the provisions of this ordinance are hereby repealed as to such inconsistency only.

BE IT FURTHER ORDAINED that this ordinance shall take effect twenty (20) days after its final passage and publication as provided by law.

BE IT FURTHER ORDAINED that if any provision of this ordinance is declared invalid, such invalidity shall not affect the other provisions of this ordinance. Furthermore, the other provisions of this ordinance are deemed to be severable and remain in full force and effect.

BE IT FURTHER ORDAINED that pursuant to N.J.S.A. 52:27BBB-23 and N.J.S.A. 40:69A-41, a true copy of this Ordinance shall be forwarded to the Mayor, who shall have ten (10) days from the receipt thereof to approve or veto this Ordinance. Additionally, pursuant to N.J.S.A. 52:27BBB-23, a true copy of this Ordinance shall be forwarded to the State Commissioner of Community Affairs, who shall have ten (10) days from the receipt thereof to veto this Ordinance, and the action by the Commissioner regarding this Ordinance shall supersede any action by the Mayor on the same Ordinance. All notices of approval and/or veto shall be filed in the Office of the Municipal Clerk.

Date of Introduction: March 12, 2024

The above has been reviewed
and approved as to form.

DANIEL S. BLACKBURN
City Attorney

ANGEL FUENTES
President City Council

VICTOR CARSTARPHEN
Mayor

ATTEST: _____
LUIS PASTORIZA
Municipal Clerk

DB:dh
03-12-24

**AN ORDINANCE DESIGNATING RESTRICTED RESIDENTIAL PARKING ZONES
FOR INDIVIDUALS WITH DISABILITIES IN CERTAIN AREAS IN THE CITY OF
CAMDEN AS HANDICAP PARKING PRIVILEGES ONLY**

WHEREAS, Frances May Jackson, upon providing the appropriate proof that she is the holder of the required specifications, seeks to have handicapped parking as a Type #1 permit in front of or near her home at 213 Erie Street; and

WHEREAS, Etanislao Rosado upon providing the appropriate proof that he is the holder of the required specifications, seeks to have handicapped parking as a Type #1 permit in front of or near his home at 1043 Beideman Avenue; and

WHEREAS, Ricardo Cordero, upon providing the appropriate proof that he is the holder of the required specifications, seeks to have handicapped parking as a Type #1 permit in front of or near his home at 1002 Collings Road; and

WHEREAS, Wilbert Cotton, upon providing the appropriate proof that he is the holder of the required specifications, seeks to have handicapped parking as a Type #1 permit in front of or near his home at 1264 Everett Street; and

WHEREAS, Vanessa L. Gourdine, upon providing the appropriate proof that she is the holder of the required specifications, seeks to have handicapped parking as a Type #1 permit in front of or near her home at 1515 Mt. Ephraim; and

WHEREAS, Maurice Potter, upon providing the appropriate proof that he is the holder of the required specifications, seeks to have handicapped parking as a Type #1 permit in front of or near his home at 2904 Royden Street; and

WHEREAS, Aida I. Calaf, upon providing the appropriate proof that she is the holder of the required specifications, seeks to have handicapped parking as a Type #1 permit in front of or near her home at 430 S. 3rd Street; and

WHEREAS, Nettie Bussey-Berian, upon providing the appropriate proof that she is the holder of the required specifications, seeks to have handicapped parking as a Type #1 permit in front of or near her home at 345 Erie Street; and

WHEREAS, Maria I. Cedeno Martinez, upon providing the appropriate proof that she is the holder of the required specifications, seeks to have handicapped parking as a Type #1 permit in front of or near her home at 1029 Liberty Street; and

WHEREAS, Regina Rowan, upon providing the appropriate proof that she is the holder of the required specifications, seeks to have handicapped parking as a Type #1 permit in front of or near her home at 1671 Minnesota Road; and

WHEREAS, Belinda R. Young, upon providing the appropriate proof that she is the holder of the required specifications, seeks to have handicapped parking as a Type #1 permit in front of or near her home at 3155 Colorado Road; and

WHEREAS, Heriberta Gonzalez, upon providing the appropriate proof that he is the holder of the required specifications, seeks to have personalized signage handicapped parking as a Type #2 permit in front of or near his home at 1040 Mechanic Street; and

WHEREAS, Kimberly S. Ortega, upon providing the appropriate proof that she is the holder of the required specifications, seeks to have personalized signage handicapped parking as a Type #2 permit in front of or near her home at 312 Morse Street; and

WHEREAS, Raquel M. Cabral-Marte, upon providing the appropriate proof that she is the holder of the required specifications, seeks to have personalized signage handicapped parking as a Type #2 permit in front of or near her home at 2040 Berwick Street; and

WHEREAS, Earl Alford, upon providing the appropriate proof that he is the holder of the required specifications, seeks to have personalized signage handicapped parking as a Type #2 permit in front of or near his home at 517 Royal Avenue; and

WHEREAS, Vivian Brice, upon providing the appropriate proof that she is the holder of the required specifications, seeks to have personalized signage handicapped parking as a Type #2 permit in front of or near her home at 1612 Fillmore Street; and

WHEREAS, Donald E. White, upon providing the appropriate proof that he is the holder of the required specifications, seeks to have personalized signage handicapped parking as a Type #2 permit in front of or near his home at 3217 Federal Street; and

WHEREAS, Michael A. Smith, upon providing the appropriate proof that he is the holder of the required specifications, seeks to have personalized signage handicapped parking as a Type #2 permit in front of or near his home at 2748 Arthur Avenue; now, therefore

BE IT ORDAINED, by the City Council of the City of Camden that, all the addresses listed above, shall be designated as either a Type 1 or Type 2 "Handicapped Parking" to have access to parking or personalized signage during the period of time that the said premises are occupied by the handicapped individuals.

SECTION 1. Type 1 Handicapped Parking locations shall be reserved for any handicapped operator. All others shall be prohibited from parking in such space.

SECTION 2. Type 2 Handicapped Parking locations shall only be utilized by the approved applicant and only by the vehicle whose license plate corresponds with the license plate number on the posted sign. All others shall be prohibited from parking in such space.

SECTION 3. By the adoption of this ordinance, we are creating a schedule of Personalized Signage "Handicapped Parking" areas, including those set forth herein and including any other "Handicapped Parking" areas heretofore adopted by ordinance. Any ordinance prohibiting parking at the location specified is hereby rescinded and repealed, in part, wherein it conflicts with the ordinance to be adopted.

SECTION 4. Any portion of this ordinance not herein amended and supplemented shall remain in full force and effect.

SECTION 5. All ordinances or parts of ordinances inconsistent with the provisions of this ordinance are hereby repealed as to such inconsistency only.

SECTION 6. This ordinance shall take effect twenty (20) days after its final passage and publication as provided by law.

BE IT FURTHER ORDAINED, that pursuant to N.J.S.A. 52:27BBB-23 and N.J.S.A. 40:69A-41, a true copy of this Ordinance shall be forwarded to the Mayor, who shall have ten (10) days from the receipt thereof to approve or veto this Ordinance. Additionally, pursuant to N.J.S.A. 52:27BBB-23, a true copy of this Ordinance shall be forwarded to the State Commissioner of Community Affairs, who shall have ten (10) days from the receipt thereof to veto this Ordinance, and the action by the Commissioner regarding this Ordinance shall supersede any action by the Mayor on the same Ordinance. All notices of approval and/or veto shall be filed in the Office of the Municipal Clerk.

Date of Introduction: March 12, 2024

The above has been reviewed
and approved as to form.



DANIEL S. BLACKBURN
City Attorney

ANGEL FUENTES
President, City Council

VICTOR CARSTARPHEN
Mayor

ATTEST: _____
LUIS PASTORIZA
Municipal Clerk



CITY OF CAMDEN — CITY COUNCIL ACTION REQUEST FORM

COUNCIL MEETING DATE: MARCH 12, 2024

TO: City Council
FROM: Keith L. Walker, Director of Public Works

TITLE OF ORDINANCE/RESOLUTION: AN ORDINANCE DESIGNATING RESTRICTED RESIDENTIAL PARKING ZONES FOR INDIVIDUALS WITH DISABILITIES TO CERTAIN AREAS IN THE CITY OF CAMDEN AS HANDICAP PARKING PRIVILEGES ONLY

Point of Contact:	Keith L. Walker	Public Works	757-7139	kewalker@ci.camden.nj.us
	Name	Department-Division-Bureau	Phone	Email

ENDORSEMENTS

	Recommend Approval (Y/N)	Signature	Date	Comments
Responsible Department Director	Y		2-16-24	
Supporting Department Director (if necessary)				
Director of Grants Management				
Qualified Purchasing Agent				
Director of Finance				

Approved by: 
Business Administrator

Signature Date 2/22

- Attachments:
1. Disabled Parking Approvals Submission – March 12, 2024 Council Meeting

“Walk-on” note: All walk-on legislation must be pre-approved by the Business Administrator. The Department Director and Contact Person are jointly responsible for delivering all necessary documents to the City Clerk for distribution at the Council Meeting.

Received by: 
City Attorney

Signature Date FEB 29 2024

EXECUTIVE SUMMARY

TITLE OF ORDINANCE/RESOLUTION: *AN ORDINANCE DESIGNATING RESTRICTED RESIDENTIAL PARKING ZONES FOR INDIVIDUALS WITH DISABILITIES TO CERTAIN AREAS IN THE CITY OF CAMDEN AS HANDICAP PARKING PRIVILEGES ONLY*

FACTS/BACKGROUND:

- Ordinance establishing a handicapped parking zone in front of a residence occupied by an individual with disability, who has been issued a windshield placard or wheelchair symbol license plate for the vehicle registered by the individual, or a family member who provides transportation for the individual with disability.

AMOUNT OF PROPOSED CONTRACT or TOTAL COST OF PROPOSAL: N/A

IMPACT STATEMENT:

- If City Council approves the legislation, City residents issued disabled parking placards or vehicle plates, who have submitted application to the City and been approved for disabled parking privileges, will have disabled parking privileges established at their residence.

SUBJECT MATTER EXPERTS/ADVOCATES:

- **Keith L. Walker, Director of Public Works**
 - Attendance: Yes

COORDINATION: N/A

Prepared by: Angela M. Watkins

(856) 757-7139/ anjohnst@ci.camden.nj.us

Name

Phone/Email



**INDIVIDUALS WITH DISABILITIES
HANDICAPPED PARKING ZONE APPROVALS**
Submitted for City Council Meeting of: March 12, 2024

APPLICANT	ADDRESS	FEE PAID	PLACARD #/ PLATE #	PERMIT TYPE
1. Frances May Jackson	213 Erie St	120.00	P2420272	TYPE 1
2. Etanislao Rosado	1043 Beideman Ave	120.00	P2764053	TYPE 1
3. Ricardo Cordero	1002 Collings Rd	120.00	P2764049	TYPE 1
4. Wilbert Cotton	1264 Everett St	120.00	P2763148	TYPE 1
3. Vanessa L. Gourdine	1515 Mt Ephraim Ave	120.00	P2768154	TYPE 1
4. Maurice Potter	2904 Royden St	120.00	P2501124	TYPE 1
5. Aida I. Calaf	430 S 3rd St	120.00	P2765638	TYPE 1
6. Nettie Bussey-Berian	345 Erie St	120.00	P2774071	TYPE 1
7. Maria I. Cedeno Martinez	1029 Liberty St	120.00	P2384653	TYPE 1
8. Regina Rowan	1671 Minnesota Rd	120.00	P2802580	TYPE 1
9. Belinda R. Young	3155 Colorado Rd	120.00	P2802581	TYPE 1
10. Heriberta Gonzalez	1040 Mechanic St	145.00	7981HG	TYPE 2
11. Kimberly S. Ortega	312 Morse St	145.00	7281HE	TYPE 2
12. Raquel M. Cabral-Marte	2040 Berwick St	145.00	3823HK	TYPE 2
13. Earl Alford	517 Royal Ave	145.00	V57MCF	TYPE 2
14. Vivian Brice	1612 Fillmore St	145.00	2494HK	TYPE 2
15. Donald E. White	3217 Federal St	45.00	8395HJ	TYPE 2 upgrade
16. Michael A. Smith	2748 Arthur Ave	145.00	2394HK	TYPE 2

0-8

DB:dh
03-12-24

**ORDINANCE AUTHORIZING THE REMOVAL OF DESIGNATED RESIDENTIAL
PARKING ZONES FOR INDIVIDUALS WITH DISABILITIES IN CERTAIN
LOCATIONS**

WHEREAS, an ordinance was adopted designating a "Handicapped Parking Only" area for the following properties:

1154 Princess Avenue	Lora Butler
1449 Princess Avenue	Alice E. Gatewood
1249 Magnolia Avenue	Shermain Gay
1442 Princess Avenue	Louise Kirkland
1675 Minnesota Road	Marisol Montero
1338 Decatur Street	Alma Peterson
1436 Belleview Avenue	Jessica Ramos
10 Ablett Village	Cruz Rivera
319 Liberty Street	Tiwaney Robinson
1410 Baird Blvd	Dorothy Rodgers
529 Pfeiffer Street	Elba Rosario
335 Fountain Avenue	Jason Velez
1532 Bradley Avenue	Nathalee Williams
833 Spruce Street	Dawn Mears

WHEREAS, it has been advised that the individual(s), no longer need accessible parking at the above location(s) due to no response to renewal correspondence, no payment of annual renewal fees and/or by request as per the individual; now, therefore

BE IT ORDAINED, by the City Council of the City of Camden that the provisions of said ordinance applicable to the properties listed above is hereby removed.

SECTION 1. All ordinances or parts of ordinances inconsistent with the provisions of this ordinance are hereby repealed as to such inconsistency only.

SECTION 2. This ordinance shall take effect twenty (20) days after its final passage and publication as provided by law.

SECTION 3. If any provision of this ordinance is declared invalid, such invalidity shall not affect the other provisions of this ordinance. Furthermore, the other provisions of this ordinance are deemed to be severable and remain in full force and effect.

BE IT FURTHER ORDAINED, that pursuant to N.J.S.A. 52:27BBB-23 and N.J.S.A. 40:69A-41, a true copy of this Ordinance shall be forwarded to the Mayor, who shall have ten (10) days from the receipt thereof to approve or veto this Ordinance. Additionally, pursuant to N.J.S.A. 52:27BBB-23, a true copy of this Ordinance shall be forwarded to the State Commissioner of Community Affairs, who shall have ten (10) days from the receipt thereof to veto this Ordinance, and the action by the Commissioner regarding this Ordinance shall supersede any action by the Mayor on the same Ordinance. All notices of approval and/or veto shall be filed in the Office of the Municipal Clerk.

Date of Introduction: March 12, 2024

The above has been reviewed and approved as to form.

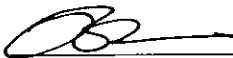
DANIEL S. BLACKBURN
City Attorney

ANGEL FUENTES
President, City Council

VICTOR CARSTARPHEN
Mayor

ATTEST: _____
LUIS PASTORIZA
Municipal Clerk



CITY OF CAMDEN — CITY COUNCIL ACTION REQUEST FORM

COUNCIL MEETING DATE: MARCH 12, 2024

TO: City Council
FROM: Keith L. Walker, Director of Public Works

TITLE OF ORDINANCE/RESOLUTION: *ORDINANCE AUTHORIZING THE REMOVAL OF DESIGNATED RESIDENTIAL PARKING ZONES FOR INDIVIDUALS WITH DISABILITIES IN CERTAIN LOCATIONS*

Point of Contact:	Keith L. Walker	Public Works	757-7139	kewalker@ci.camden.nj.us
	Name	Department-Division- Bureau	Phone	Email

ENDORSEMENTS

	Recommend Approval (Y/N)	Signature	Date	Comments
Responsible Department Director Supporting Department Director (if necessary) Director of Grants Management Qualified Purchasing Agent Director of Finance	Y		2-16-24	

Approved by:
Business Administrator

2/22

Signature

Date

Attachments (list and attach all available):

1. Disabled Parking Removals Submission – March 12, 2024 Council Meeting

“Walk-on” note: All walk-on legislation must be pre-approved by the Business Administrator. The Department Director and Contact Person are jointly responsible for delivering all necessary documents to the City Clerk for distribution at the Council Meeting.

Received by:
City Attorney

FEB 29 2024

Signature

Date

EXECUTIVE SUMMARY

TITLE OF ORDINANCE/RESOLUTION: *ORDINANCE AUTHORIZING THE REMOVAL OF DESIGNATED RESIDENTIAL PARKING ZONES FOR INDIVIDUALS WITH DISABILITIES IN CERTAIN LOCATIONS*

FACTS/BACKGROUND:

- Ordinance authorizing the removal of designated restricted parking zone(s) for disabled individual parking applicants who did not renew their permits.

AMOUNT OF PROPOSED CONTRACT or TOTAL COST OF PROPOSAL: N/A

IMPACT STATEMENT:

- If City Council approves the legislation, the disabled parking signage at the designated location will be removed in accordance with the Disabled Parking approval/removal procedures.

SUBJECT MATTER EXPERTS/ADVOCATES:

- **Keith L. Walker, Director of Public Works**
 - Attendance: Yes

COORDINATION: N/A

Prepared by: Angela M. Watkins

(856) 757-7139/ anjohnst@ci.camden.nj.us

Name

Phone/Email



INDIVIDUALS WITH DISABILITIES
DESIGNATED PARKING ZONE REMOVALS
Submitted for City Council Meeting of: March 12, 2024

APPLICANT	ADDRESS	REASON FOR REMOVAL OF ZONE
1. Lora Butler	1154 Princess Ave	no response to removal correspondence
2. Alice E. Gatewood	1449 Princess Ave	no response to removal correspondence
3. Shermain Gay	1249 Magnolia Ave	no response to removal correspondence
4. Louise Kirland	1442 Princess Ave	no response to renewal correspondence
5. Marisol Montero	1675 Minnesota Rd	no response to renewal correspondence
6. Alma Peterson	1338 Decatur St	no response to renewal correspondence
7. Jessica Ramos	1436 Belleview Ave	no response to renewal correspondence
8. Cruz Rivera	10 Ablett Village	no response to renewal correspondence
9. Tiwany Robinson	319 Liberty St	no response to renewal correspondence
10. Dorothy Rodgers	1410 Baird Blvd	no response to renewal correspondence
11. Elba Rosario	529 Pfeiffer St	no response to renewal correspondence
12. Jason Velez	335 Fountain Ave	no response to renewal correspondence
13. Nathalee Williams	1532 Bradley Ave	no response to renewal correspondence
14. Dawn Mears	833 Spruce St	no response to renewal correspondence

Ordinances 2nd
Reading

DB:dh
02-13-24

ORDINANCE ESTABLISHING THE RELOCATION OF A BUS STOP AND THE REMOVAL OF TWO (2) BUS STOPS ALONG BROADWAY AND ATLANTIC AVENUE

WHEREAS, the New Jersey Department of Transportation desires to relocate a bus stop; now, therefore

BE IT ORDAINED, by the governing body of the City of Camden pursuant to N.J.S.A. 39:4-8(e) the following described location is designated as a bus stop:

ADDED BUS STOP:

1. Along Broadway, Northbound, on the easterly side thereof at:

- a. Atlantic Avenue-Far Side
Beginning at the northerly curb line of Atlantic Avenue and extending 100 feet northerly therefrom. (15021)

BE IT FURTHER ORDAINED, by the governing body of the City of Camden pursuant to N.J.S.A. 39:4-8(e) the following described locations are deleted as bus stops:

DELETE BUS STOPS:

1. Along Broadway, Northbound, on the easterly side thereof at:

- a. Atlantic Avenue-Near Side
Beginning at the southerly curb line of Atlantic Avenue and extending 105 feet southerly therefrom. (15021)

2. Along Broadway, Southbound, on the westerly side thereof at:

- a. Atlantic Avenue-Far Side
Beginning at the southerly curb line of Atlantic Avenue and extending 100 feet southerly therefrom. (15049)

BE IT FURTHER ORDAINED, that the City of Camden will enforce the needed traffic regulations relating to the above-mentioned bus stops and provide the necessary police security to ensure the safety of the traveling public and request appropriate law enforcement agencies to do so.

SECTION 1. All ordinances or parts of ordinances inconsistent with the provisions of this ordinance are hereby repealed as to such inconsistency only.

SECTION 2. This ordinance shall take effect twenty (20) days after its final passage and publication as provided by law.

SECTION 3. If any provision of this ordinance is declared invalid, such invalidity shall not affect the other provisions of this ordinance. Furthermore, the other provisions of this ordinance are deemed to be severable and remain in full force and effect.

BE IT FURTHER ORDAINED, that pursuant to N.J.S.A. 52:27BBB-23 and N.J.S.A. 40:69A-41, a true copy of this Ordinance shall be forwarded to the Mayor, who shall have ten (10) days from the receipt thereof to approve or veto this Ordinance. Additionally, pursuant to N.J.S.A. 52:27BBB-23, a true copy of this Ordinance shall be forwarded to the State Commissioner of Community Affairs, who shall have ten (10) days from the receipt thereof to veto this Ordinance, and the action by the Commissioner regarding this Ordinance shall supersede any action by the Mayor on the same Ordinance. All notices of approval and/or veto shall be filed in the Office of the Municipal Clerk.

Date of Introduction: February 13, 2024

The above has been reviewed
and approved as to form.



DANIEL S. BLACKBURN
City Attorney

ANGEL FUENTES
President, City Council

VICTOR CARSTARPHEN
Mayor

ATTEST: _____
LUIS PASTORIZA
Municipal Clerk

DB:dh
02-13-24

ORDINANCE AMENDING SECTION 870-230R OF THE CAMDEN CODE ALLOWING FOR THE WAIVER OF THE CASH CONTRIBUTION REQUIREMENT AS APPROVED BY THE ZONING OFFICER AND ALSO AMENDING SECTION 870-268C OF THE CAMDEN CODE REQUIRING THAT THE SUBMISSION OF ALL APPLICATIONS UNDER THIS SECTION ARE TO ALSO TAKE PLACE THROUGH ELECTRONIC SUBMISSION

WHEREAS, current Section 870-230R requires that in the case where a variance is granted due to demonstrated hardship or other good and sufficient reasons, where off-street parking requirements are not met, an applicant must make a cash contribution to the City for each required parking space not provided for which funds can be used to support a program for the construction of public parking lots; and

WHEREAS, the Administration now seeks to amend Section 870-230R to include language allowing the Zoning Officer the discretion to partially or fully waive this cash contribution requirement thereby allowing for equity and fairness in the application process as between large and small scale developers in the City; and

WHEREAS, the Administration also seeks to amend Section 870-268C governing all applications submitted pursuant to Section 870 to require that all such applications must also be submitted electronically; and

WHEREAS, the City Council of the City of Camden concurs with these suggested amendments; now therefore

BE IT ORDAINED, by the City Council of the City of Camden, that Section 870-230R of the Camden City Code is hereby amended, as follows:

Section 870-230 R.

A variance and public notice shall be required if the proper number of parking spaces are not provided on a lot. If off-street parking requirements are not met as provided above, the developer or applicant must obtain approval of a parking space variance subject to the provisions of this chapter. If a variance is granted due to demonstrated hardship or other good and sufficient reasons, the applicant shall then make a cash contribution to the City for each required space not provided in order to develop a program of constructing public parking lots unless the Zoning Officer has determined that a developer is entitled to a partial or complete waiver of this cash contribution requirement. The contribution shall be in an amount equal to the cost of providing the required minimum number of parking spaces, to be calculated by the City Engineer. If the Zoning Officer determines that a partial or complete waiver of the cash contribution requirement is appropriate, the Zoning Officer shall so state the reasons for such waiver in writing.

And

BE IT FURTHER ORDAINED, by the City Council of the City of Camden, that Section 870-268C of the Camden City Code is hereby amended, as follows:

Section 870-268 C.

Submission hours are 8:30 a.m. to 4:30 p.m., Monday through Friday. All applications must be stamped "received" by the Division of Planning and Zoning. No outside dropoffs will be processed. All applications must also be submitted electronically via electronic submission.

BE IT FURTHER ORDAINED that all ordinances or parts of ordinances inconsistent with the provisions of this ordinance are hereby repealed as to such inconsistency only.

BE IT FURTHER ORDAINED that this ordinance shall take effect twenty (20) days after its final passage and publication as provided by law.

BE IT FURTHER ORDAINED that if any provision of this ordinance is declared invalid, such invalidity shall not affect the other provisions of this ordinance. Furthermore, the other provisions of this ordinance are deemed to be severable and remain in full force and effect.

BE IT FURTHER ORDAINED that pursuant to N.J.S.A. 52:27BBB-23 and N.J.S.A. 40:69A-41, a true copy of this Ordinance shall be forwarded to the Mayor, who shall have ten (10) days from the receipt thereof to approve or veto this Ordinance. Additionally, pursuant to N.J.S.A. 52:27BBB-23, a true copy of this Ordinance shall be forwarded to the State Commissioner of Community Affairs, who shall have ten (10) days from the receipt thereof to veto this Ordinance, and the action by the Commissioner regarding this Ordinance shall supersede any action by the Mayor on the same Ordinance. All notices of approval and/or veto shall be filed in the Office of the Municipal Clerk.

Date of Introduction: February 13, 2024

The above has been reviewed
and approved as to form.



DANIEL S. BLACKBURN
City Attorney

ANGEL FUENTES
President City Council

VICTOR CARSTARPHEN
Mayor

ATTEST: _____
LUIS PASTORIZA
Municipal Clerk

DB:HM
02-13-24

AN ORDINANCE AMENDING AND SUPPLEMENTING ORDINANCE 717, ADOPTED DECEMBER 27, 1945, FOR THE REGULATION OF VEHICLES AND PEDESTRIANS IN THE STREETS OF THE CITY OF CAMDEN AND THE ENFORCEMENT THEREOF, FOR THE PURPOSE OF INSTALLING TWO ADDITIONAL STOP SIGNS AT THE EAST AND WEST APPROACHES OF THE INTERSECTION AT TWENTY-NINTH AND CRAMER STREETS IN ORDER TO MAKE THE INTERSECTION A FOUR-WAY STOP CONTROLLED INTERSECTION

WHEREAS, the intersection at Twenty-ninth and Cramer Streets currently has two (2) stop signs on 29th Street at this intersection; and

WHEREAS, in the past, this intersection has had numerous accidents; and

WHEREAS, the Municipal Engineer of the City of Camden has determined that, for public safety purposes, including the need to reduce vehicle speeds and to lessen the number of accidents occurring at this intersection, this intersection should now have four stop signs at this intersection, thereby providing for a four-way stop at this intersection; and

WHEREAS, this four-way stop intersection is permitted pursuant to New Jersey Motor Vehicle and New Jersey Department of Transportation statutes and regulations; now therefore

BE IT ORDAINED, by the City Council of the City of Camden, as follows:

SECTION 1. An ordinance entitled, "An Ordinance Providing For The Regulation of Vehicles and Pedestrians in the Streets of the City of Camden and the Enforcement Thereof," Ordinance adopted December 27, 1945, is hereby amended and supplemented to include as follows:

"SIGNS", shall be amended and supplemented to include the following:

Stop sign Controlled Intersection: Stop Signs

<u>Name of Street</u>	<u>Direction</u>	<u>Limits</u>	
Cramer Street @ 29 th Street Sign	Eastbound	Intersection	Stop
Cramer Street @ 29 th Street Sign	Westbound	Intersection	Stop

SECTION 2. Any portion of this ordinance not herein amended and supplemented shall remain in full force and effect.

SECTION 3. All ordinance or parts of ordinances inconsistent with the provisions of this ordinance are hereby repealed as to such inconsistency only.

SECTION 4. This ordinance shall take effect twenty (20) days after final passage and publication as provided by law.

BE IT FURTHER ORDAINED that pursuant to N.J.S.A. 52:27BBB-23 and N.J.S.A. 40:69A-41, a true copy of this Ordinance shall be forwarded to the Mayor, who shall have ten (10) days from the receipt thereof to approve or veto this Ordinance. Additionally, pursuant to N.J.S.A. 52:27BBB-23, a true copy of this Ordinance shall be forwarded to the State Commissioner of Community Affairs, who shall have ten (10) days from the receipt thereof to veto this Ordinance, and the action by the Commissioner regarding this Ordinance shall supersede any action by the Mayor on the same Ordinance. All notices of approval and/or veto shall be filed in the Office of the Municipal Clerk.

Date of Introduction: February 13, 2024

The above has been reviewed
and approved as to form.



DANIEL S. BLACKBURN
City Attorney

ANGEL FUENTES
President City Council

VICTOR CARSTARPHEN
Mayor

ATTEST: _____
LUIS PASTORIZA
Municipal Clerk

0-4

DB:dh
02-13-24

**AN ORDINANCE DESIGNATING RESTRICTED RESIDENTIAL PARKING ZONES
FOR INDIVIDUALS WITH DISABILITIES IN CERTAIN AREAS IN THE CITY OF
CAMDEN AS HANDICAP PARKING PRIVILEGES ONLY**

WHEREAS, Ana L Rodriguez Martinez, upon providing the appropriate proof that she is the holder of the required specifications, seeks to have handicapped parking as a Type #1 permit in front of or near her home at 2909 Royden Street; and

WHEREAS, Deborah J. Kendall upon providing the appropriate proof that she is the holder of the required specifications, seeks to have handicapped parking as a Type #1 permit in front of or near her home at 1024 Kenwood Avenue; and

WHEREAS, Elsa Obando, upon providing the appropriate proof that she is the holder of the required specifications, seeks to have handicapped parking as a Type #1 permit in front of or near her home at 109 N. 24th Street; and

WHEREAS, Sharon Valdes, upon providing the appropriate proof that she is the holder of the required specifications, seeks to have handicapped parking as a Type #1 permit in front of or near her home at 2579 Baird Blvd.; and

WHEREAS, Nicole A. Baker, upon providing the appropriate proof that she is the holder of the required specifications, seeks to have personalized signage handicapped parking as a Type #2 permit in front of or near her home at 620 Raritan Street; and

WHEREAS, Reinaldo Cortes, upon providing the appropriate proof that he is the holder of the required specifications, seeks to have personalized signage handicapped parking as a Type #2 permit in front of or near his home at 1107 N. 26th Street; now, therefore

BE IT ORDAINED, by the City Council of the City of Camden that, all the addresses listed above, shall be designated as either a Type 1 or Type 2 "Handicapped Parking" to have access to parking or personalized signage during the period of time that the said premises are occupied by the handicapped individuals.

SECTION 1. Type 1 Handicapped Parking locations shall be reserved for any handicapped operator. All others shall be prohibited from parking in such space.

SECTION 2. Type 2 Handicapped Parking locations shall only be utilized by the approved applicant and only by the vehicle whose license plate corresponds with the license plate number on the posted sign. All others shall be prohibited from parking in such space.

SECTION 3. By the adoption of this ordinance, we are creating a schedule of Personalized Signage "Handicapped Parking" areas, including those set forth herein and including any other "Handicapped Parking" areas heretofore adopted by ordinance. Any ordinance prohibiting parking at the location specified is hereby rescinded and repealed, in part, wherein it conflicts with the ordinance to be adopted.

SECTION 4. Any portion of this ordinance not herein amended and supplemented shall remain in full force and effect.

SECTION 5. All ordinances or parts of ordinances inconsistent with the provisions of this ordinance are hereby repealed as to such inconsistency only.

SECTION 6. This ordinance shall take effect twenty (20) days after its final passage and publication as provided by law.

BE IT FURTHER ORDAINED, that pursuant to N.J.S.A. 52:27BBB-23 and N.J.S.A. 40:69A-41, a true copy of this Ordinance shall be forwarded to the Mayor, who shall have ten (10) days from the receipt thereof to approve or veto this Ordinance. Additionally, pursuant to N.J.S.A. 52:27BBB-23, a true copy of this Ordinance shall be forwarded to

the State Commissioner of Community Affairs, who shall have ten (10) days from the receipt thereof to veto this Ordinance, and the action by the Commissioner regarding this Ordinance shall supersede any action by the Mayor on the same Ordinance. All notices of approval and/or veto shall be filed in the Office of the Municipal Clerk.

Date: February 13, 2024

The above has been reviewed
and approved as to form.



DANIEL S. BLACKBURN
City Attorney

ANGEL FUENTES
President, City Council

VICTOR CARSTARPHEN
Mayor

ATTEST: _____
LUIS PASTORIZA
Municipal Clerk

**ORDINANCE AUTHORIZING THE REMOVAL OF DESIGNATED RESIDENTIAL
PARKING ZONES FOR INDIVIDUALS WITH DISABILITIES IN CERTAIN
LOCATIONS**

WHEREAS, an ordinance was adopted designating a "Handicapped Parking Only" area for the following properties:

2967 Hartford Road	Luz R. Aviles
831 N. 4 th Street	Lourdes E. Cruz
366 Raritan Street	Unknown Designee
1486 Princess Avenue	Velton Thomas
3141 S. Congress Road	Kim Russ

WHEREAS, it has been advised that the individual(s), no longer need accessible parking at the above location(s) due to no response to renewal correspondence, no payment of annual renewal fees and/or by request as per the individual; now, therefore

BE IT ORDAINED, by the City Council of the City of Camden that the provisions of said ordinance applicable to the properties listed above is hereby removed.

SECTION 1. All ordinances or parts of ordinances inconsistent with the provisions of this ordinance are hereby repealed as to such inconsistency only.

SECTION 2. This ordinance shall take effect twenty (20) days after its final passage and publication as provided by law.

SECTION 3. If any provision of this ordinance is declared invalid, such invalidity shall not affect the other provisions of this ordinance. Furthermore, the other provisions of this ordinance are deemed to be severable and remain in full force and effect.

BE IT FURTHER ORDAINED, that pursuant to N.J.S.A. 52:27BBB-23 and N.J.S.A. 40:69A-41, a true copy of this Ordinance shall be forwarded to the Mayor, who shall have ten (10) days from the receipt thereof to approve or veto this Ordinance. Additionally, pursuant to N.J.S.A. 52:27BBB-23, a true copy of this Ordinance shall be forwarded to the State Commissioner of Community Affairs, who shall have ten (10) days from the receipt thereof to veto this Ordinance, and the action by the Commissioner regarding this Ordinance shall supersede any action by the Mayor on the same Ordinance. All notices of approval and/or veto shall be filed in the Office of the Municipal Clerk.

Date of Introduction: February 13, 2024

The above has been reviewed
and approved as to form.

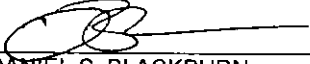

DANIEL S. BLACKBURN
City Attorney

ANGEL FUENTES
President, City Council

VICTOR CARSTARPHEN
Mayor

ATTEST: _____
LUIS PASTORIZA
Municipal Clerk

Resolutions

A-1

ALL COUNCIL
3/12/2024

**RESOLUTION DESIGNATING DARRYL SEARLES AS THE CITY OF CAMDEN
EMPLOYEE OF THE MONTH FOR MARCH 2024**

WHEREAS, this Council, in cooperation with the Administration and the City's Employees and their union representatives, has established a program for honoring its employees by the designations of an "Employee of the Month"; and

WHEREAS, the criteria established to identify candidates for employee of the Month include:

1. Friendliness, thoughtfulness and dependability
2. Duties performed in a professional manner
3. Ability to work with others
4. An exemplary representative of his or her department
5. A positive role model
6. Pride in job performance
7. A positive attendance record; and

WHEREAS, Darryl Searles, Customer Service Representative in the Department of Information Technology, has been nominated as "Employee of the Month", and this Council, having reviewed the information presented in support of the nomination, believes that this honor should be bestowed on said **Darryl Searles**; and

WHEREAS, Darryl Searles has worked for the City of Camden for approximately 15 years and has always demonstrated veritable professionalism and dedication; and

WHEREAS, the City Council of the City of Camden now seeks to Honor Mr. **Darryl Searles**; now, therefore

BE IT RESOLVED by the City Council of the City of Camden that it recognizes **Darryl Searles** as the "Employee of the Month" for March, 2024 and hereby extends to **Darryl** its congratulations as well as all rights and accouterments extended to him as a result of his selection as Employee of the Month.

BE IT FURTHER RESOLVED, that pursuant to N.J.S.A. 52:27BBB-23, a true copy of this Resolution shall be forwarded to the State Commissioner of Community Affairs, who shall have ten (10) days from the receipt thereof to veto this Resolution. All notices of veto shall be filed in the Office of the Municipal Clerk.

Date: March 12, 2024

The above has been reviewed
and approved as to form



DANIEL S. BLACKBURN
City Attorney

ANGEL FUENTES
President, City Council

ATTEST: _____
LUIS PASTORIZA
Municipal Clerk



Camden City Council
RESOLUTION / ORDINANCE REQUEST FORM

DATE: February 26, 2024

Council Meeting Date: March 12, 2024

FROM: Councilperson

Angel Fuentes, President

Falio Leyba-Martinez, 3rd Ward

Sheila Davis, Vice President, At-Large

Jannette Ramos, 4th Ward

Arthur Barclay, 1st Ward

Nohemi G. Soria-Perez, At-Large

Chris Collins, 2nd Ward

Action Requested:

**RESOLUTION DESIGNATING DARRYL SEARLES AS THE CITY OF CAMDEN EMPLOYEE
OF THE MONTH FOR MARCH 2024**

****Please attach any supporting documents

Angel Fuentes /nsb

2/26/24

Signature of Councilperson

Date

R-2

DAVIS
3/12/2024

RESOLUTION RECOGNIZING GIRL SCOUT WEEK 2024

WHEREAS, Girl Scout Week is celebrated annually in March to commemorate March 12, 1912, the day when Girl Scout's founder Juliette Gordon Low officially registered the organization's first 18 members in Savannah, Georgia; and

WHEREAS, Girl Scout Week 2024, will mark the 109th anniversary of the organization; and

WHEREAS, throughout its long and distinguished history, Girl Scouting has empowered millions of girls and women with the highest ideals of character, conduct, leadership and community service to make their local communities and the global world a better place; and

WHEREAS, Camden City is home to a number of Girl Scout troops, and the City Council is proud to acknowledge and celebrate the positive contributions these young women have made in the community; and

WHEREAS, it is appropriate that this City Council of the City of Camden honor those individuals and organizations who greatly contribute to the enrichment of Camden City, and County, its residents, and its communities; now, therefore

BE IT RESOLVED, by this City Council of the City of Camden that it hereby recognizes the week of March 10 through March 16, 2024 as Girl Scout Week in the City of Camden and expresses its gratitude to all of the Camden Girl Scouts, troop leaders and volunteers for their service to the community.

BE IT FURTHER RESOLVED, that pursuant to N.J.S.A. 52:27BBB-23, a true copy of this Resolution shall be forwarded to the State Commissioner of Community Affairs, who shall have ten (10) days from the receipt thereof to veto this Resolution. All notices of veto shall be filed in the Office of the Municipal Clerk.

Date: March 12, 2024

The above has been reviewed
and approved as to form



DANIEL S. BLACKBURN
City Attorney

ANGEL FUENTES
President, City Council

ATTEST: _____
LUIS PASTORIZA
Municipal Clerk



Camden City Council
RESOLUTION / ORDINANCE REQUEST FORM

DATE: February 22, 2024

Council Meeting Date: March 12, 2024

FROM: Councilperson

- Angel Fuentes, President
- Sheila Davis, Vice President, At-Large
- Nohemi Soria-Perez, At-Large

- Arthur Barclay, 1st Ward
- Christopher Collins, 2nd Ward
- Falio Leyba-Martinez, 3rd Ward
- Jannette Ramos, 4th Ward

Action Requested:

RESOLUTION REGONIZIN GIRL SCOUT WEEK 2024

*****Please attach any supporting documents*

Sheila Davis/*gms*

2/22/2024

Signature of Councilperson

Date

A-3

FUENTES
03/12/2024

**RESOLUTION APPOINTING ARTHUR BARCLAY TO THE BOARD OF THE CAMDEN
SPECIAL SERVICES DISTRICT, INC., A NONPROFIT CORPORATION, ASSIGNED AS THE
DISTRICT MANAGEMENT CORPORATION FOR THE CAMDEN BUSINESS
IMPROVEMENT DISTRICT**

WHEREAS, the Camden Special Services District, Inc. (CSSD), a nonprofit corporation, is assigned as the District Management Corporation for the Camden Business Improvement District; and

WHEREAS, Section 461-25A of the Camden Code provides that the Board of Directors of the District Management Corporation shall be comprised of 13 members and one shall consist of one representative of City Council which shall be the City Council President or his designee and any designee of City Council President shall be another member of City Council; and

WHEREAS, Section 461-25B of the Camden Code also provides that the term of the Board of Directors along with other rules and regulations governing the CSSD shall be set forth in its bylaws; and

WHEREAS, the City Council of the City of Camden now seeks to appoint Councilman Arthur Barclay to the Board of Directors of the CSSD, the District Management Corporation, as the City Council representative to serve a term as provided for in the bylaws governing the CSSD, the District Management Corporation; now, therefore

BE IT RESOLVED, by the City Council of the City of Camden that it hereby appoints Councilman Arthur Barclay to the Board of Directors of the CSSD, the District Management Corporation, as the City Council representative to serve a term as provided for in the bylaws governing the CSSD, the District Management Corporation.

BE IT FURTHER RESOLVED, that pursuant to N.J.S.A. 52:27BBB-23, a true copy of this Resolution shall be forwarded to the State Commissioner of Community Affairs, who shall have ten (10) days from the receipt thereof to veto this Resolution. All notices of veto shall be filed in the Office of the Municipal Clerk.

Date: March 12, 2024

The above has been reviewed
and approved as to form

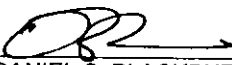

DANIEL S. BLACKBURN
City Attorney

ANGEL FUENTES
President, City Council

ATTEST: _____
LUIS PASTORIZA
Municipal Clerk



Camden City Council
RESOLUTION / ORDINANCE REQUEST FORM

DATE: February 16, 2024

Council Meeting Date: March 12, 2024

FROM: Councilperson

Angel Fuentes, President

Falio Leyba-Martinez, 3rd Ward

Sheila Davis, Vice President, At-Large

Jannette Ramos, 4th Ward

Arthur Barclay, 1st Ward

Nohemi G. Soria-Perez, At-Large

Chris Collins, 2nd Ward

Action Requested:

RESOLUTION APPOINTING COUNCILMAN ARTHUR BARCLAY TO THE BOARD OF THE CAMDEN SPECIAL SERVICES DISTRICT, INC. (CSSD), A NONPROFIT CORPORATION, ASSIGNED AS THE DISTRICT MANAGEMENT CORPORATION FOR THE CAMDEN BUSINESS IMPROVEMENT DISTRICT

****Please attach any supporting documents

Angel Fuentes /nsb

2/16/24

Signature of Councilperson

Date

FUENTES
03/12/2024

R-4

RESOLUTION APPOINTING PERRY JENKINS III TO THE ANTI-BULLYING ADVISORY BOARD TO PERFORM THE DUTIES AS PROVIDED FOR IN CHAPTER 283, AS ESTABLISHED BY MC-5392, ADOPTED ON JULY 12, 2022, AND AS AMENDED BY MC-5405, ADOPTED ON SEPTEMBER 13, 2022

WHEREAS, the City Council of the City of Camden has found that bullying can take place not only during school or at school functions but other times as well; and

WHEREAS, the City Council of the City of Camden believed that, based on the best interests of the residents of the City of Camden, an Anti-Bullying ordinance, Chapter 283, was needed and was thereby established by MC-5392, adopted on July 12, 2022; and

WHEREAS, Chapter 283 established an Anti-Bullying Advisory Board whose role includes the following:

283-8. Purpose and Duties.

1. To examine the best means to assist minors who are facing or have faced bullying in their neighborhoods.
2. To examine the types of bullying, which may include making threats, spreading rumors, conducting verbal attacks, making physical contact or other forms of verbal bullying, social bullying, cyber-bullying and physical bullying and the best means to address such bullying so that all our children can live safely and without fear within the City and its neighborhoods.
3. To possibly offer City programs for those minors who are facing bullying in their neighborhoods.
4. To examine the best means to disseminate pertinent information on bullying.
5. To make recommendations to the Mayor and City Council with regard to the Board's role and obligations pursuant to Chapter 283.

WHEREAS, chapter 283 provides that membership on the Advisory Board shall be as follows:

283-9. Membership.

1. Membership on the Anti-Bullying Advisory Board shall consist of twelve (12) members appointed by City Council as follows:
 - a. Four (4) members shall consist of student members; one student member from each Ward.
 - b. Five (5) members shall be adults who shall be members in one of the following fields: Mental Health Provider, Social Worker, Behavioral Health Therapist, Administrator- Education, Community Stakeholder, Business Owner or Operator, Juvenile Officer, Members of the faith-based community or those participating in Mentorship Programs.
 - c. One (1) member of Council to act as an advisor who shall be a non-voting member.
 - d. One (1) member of the Mayor's Office designated by the Mayor to act as an advisor who shall be a non-voting member.

WHEREAS, Chapter 283 was further amended by MC-5405, adopted on September 13, 2022 which established staggered initial terms of the five (5) member Adult Board, as follows:

283-10. Terms; vacancies; removals.

- A. The first term of the five (5) members of the Advisory Board as provided for in subsection 283-9(1) (b) above, shall be staggered with three (3) members serving for three (3) years and two (2) members serving for two (2) years. Thereafter, subsequent terms of the Advisory Board as provided for in subsection 283-9(1)(b) above, shall be for three (3) years. All other members of the Advisory Board as provided for in subsections 283-9(1) (a), (c) (d) and (e) shall be for one (1) year.

WHEREAS, **Perry Jenkins III** is a high school student, who resides in the city of Camden, and has previously attended Anti-bullying training offered by the Anti-bullying Advisory Board; and

WHEREAS, the City Council of the City of Camden now seeks to appoint **Perry Jenkins III** as a member of the Anti-Bullying Advisory Board as provided for in subsection 283-9(1)(a); now therefore

BE IT RESOLVED, by the City Council of the City of Camden hereby appoints **Perry Jenkins III** to the Anti-Bullying Advisory Board pursuant to subsection 283-9(1)(a).

BE IT FURTHER RESOLVED, by the City Council of the City of Camden that **Perry Jenkins III** shall serve on the Anti-Bullying Advisory Board pursuant to subsection 283-9(1)(a) for a term of one (1) year.

BE IT FURTHER RESOLVED, that pursuant to N.J.S.A. 52:27BBB-23, a true copy of this Resolution shall be forwarded to the State Commissioner of Community Affairs, who shall have ten (10) days from the receipt thereof to veto this Resolution. All notices of veto shall be filed in the Office of the Municipal Clerk.

Date: March 12, 2024

The above has been reviewed
and approved as to form



DANIEL S. BLACKBURN
City Attorney

ANGEL FUENTES
President, City Council

ATTEST: _____
LUIS PASTORIZA
Municipal Clerk



Camden City Council
RESOLUTION / ORDINANCE REQUEST FORM

DATE: February 16, 2024

Council Meeting Date: March 12, 2024

FROM: Councilperson

Angel Fuentes, President

Falio Leyba-Martinez, 3rd Ward

Sheila Davis, Vice President, At-Large

Jannette Ramos, 4th Ward

Arthur Barclay, 1st Ward

Nohemi G. Soria-Perez, At-Large

Chris Collins, 2nd Ward

Action Requested:

RESOLUTION APPOINTING PERRY JENKINS III TO THE ANTI-BULLYING ADVISORY BOARD TO PERFORM THE DUTIES AS PROVIDED FOR IN CHAPTER 283, AS ESTABLISHED BY MC-5392, ADOPTED ON JULY 12, 2022, AND AS AMENDED BY MC-5405, ADOPTED ON SEPTEMBER 13, 2022

****Please attach any supporting documents

Angel Fuentes / nfb

2/16/24

Signature of Councilperson

Date

R-5

FUENTES
03/12/2024

RESOLUTION APPOINTING NYREE REID TO THE ANTI-BULLYING ADVISORY BOARD TO PERFORM THE DUTIES AS PROVIDED FOR IN CHAPTER 283, AS ESTABLISHED BY MC-5392, ADOPTED ON JULY 12, 2022, AND AS AMENDED BY MC-5405, ADOPTED ON SEPTEMBER 13, 2022

WHEREAS, the City Council of the City of Camden has found that bullying can take place not only during school or at school functions but other times as well; and

WHEREAS, the City Council of the City of Camden believed that, based on the best interests of the residents of the City of Camden, an Anti-Bullying ordinance, Chapter 283, was needed and was thereby established by MC-5392, adopted on July 12, 2022; and

WHEREAS, Chapter 283 established an Anti-Bullying Advisory Board whose role includes the following:

283-8. Purpose and Duties.

1. To examine the best means to assist minors who are facing or have faced bullying in their neighborhoods.
2. To examine the types of bullying, which may include making threats, spreading rumors, conducting verbal attacks, making physical contact or other forms of verbal bullying, social bullying, cyber-bullying and physical bullying and the best means to address such bullying so that all our children can live safely and without fear within the City and its neighborhoods.
3. To possibly offer City programs for those minors who are facing bullying in their neighborhoods.
4. To examine the best means to disseminate pertinent information on bullying.
5. To make recommendations to the Mayor and City Council with regard to the Board's role and obligations pursuant to Chapter 283.

WHEREAS, chapter 283 provides that membership on the Advisory Board shall be as follows:

283-9. Membership.

1. Membership on the Anti-Bullying Advisory Board shall consist of twelve (12) members appointed by City Council as follows:
 - a. Four (4) members shall consist of student members; one student member from each Ward.
 - b. Five (5) members shall be adults who shall be members in one of the following fields: Mental Health Provider, Social Worker, Behavioral Health Therapist, Administrator- Education, Community Stakeholder, Business Owner or Operator, Juvenile Officer, Members of the faith-based community or those participating in Mentorship Programs.
 - c. One (1) member of Council to act as an advisor who shall be a non-voting member.
 - d. One (1) member of the Mayor's Office designated by the Mayor to act as an advisor who shall be a non-voting member.

- e. One (1) member of the Camden County Police Department designated by the Chief of Police to act as an advisor who shall be a non-voting member.

WHEREAS, Chapter 283 was further amended by MC-5405, adopted on September 13, 2022 which established staggered initial terms of the five (5) member Adult Board, as follows:

283-10. Terms; vacancies; removals.

- A. The first term of the five (5) members of the Advisory Board as provided for in subsection 283-9(1) (b) above, shall be staggered with three (3) members serving for three (3) years and two (2) members serving for two (2) years. Thereafter, subsequent terms of the Advisory Board as provided for in subsection 283-9(1)(b) above, shall be for three (3) years. All other members of the Advisory Board as provided for in subsections 283-9(1) (a), (c) (d) and (e) shall be for one (1) year.

WHEREAS, Arthur Barklay, upon his election to the City Council of the City of Camden, resigned from the Anti-Bullying Advisory Board; and

WHEREAS, the City Council of the City of Camden now seeks to appoint **Nyree Reid** to replace Arthur Barklay as a member of the Anti-Bullying Advisory Board as provided for in subsection 283-9(1)(b); now therefore

BE IT RESOLVED, by the City Council of the City of Camden hereby appoints **Nyree Reid** to the Anti-Bullying Advisory Board pursuant to subsection 283-9(1)(b).

BE IT FURTHER RESOLVED, by the City Council of the City of Camden that **Nyree Reid** shall serve on the Anti-Bullying Advisory Board pursuant to subsection 283-9(1)(b) for a term of three (3) years.

BE IT FURTHER RESOLVED, that pursuant to N.J.S.A. 52:27BBB-23, a true copy of this Resolution shall be forwarded to the State Commissioner of Community Affairs, who shall have ten (10) days from the receipt thereof to veto this Resolution. All notices of veto shall be filed in the Office of the Municipal Clerk.

Date: March 12, 2024

The above has been reviewed and approved as to form



DANIEL S. BLACKBURN
City Attorney

ANGEL FUENTES
President, City Council

ATTEST: _____
LUIS PASTORIZA
Municipal Clerk



Camden City Council
RESOLUTION / ORDINANCE REQUEST FORM

DATE: February 8, 2024

Council Meeting Date: March 12,
February 29, 2024

FROM: Councilperson

- | | |
|---|---|
| <input checked="" type="checkbox"/> Angel Fuentes, President | <input type="checkbox"/> Shaneka Boucher, 1 st Ward |
| <input type="checkbox"/> Sheila Davis, Vice President, At-Large | <input type="checkbox"/> Christopher Collins, 2 nd Ward |
| <input type="checkbox"/> Nohemi Soria-Perez, At-Large | <input type="checkbox"/> Marilyn Torres, 3 rd Ward |
| | <input type="checkbox"/> Felisha Reyes-Morton, 4 th Ward |

Action Requested:

RESOLUTION APPOINTING NYREE REID TO THE ANTI-BULLYING ADVISORY BOARD TO PERFORM THE DUTIES AS PROVIDED FOR IN CHAPTER 283, AS ESTABLISHED BY MC-5392, ADOPTED ON JULY 12, 2022, AND AS AMENDED BY MC-5405, ADOPTED ON SEPTEMBER 13, 2022

****Please attach any supporting documents

Angel Fuentes/m

2/8/2024

Signature of Councilperson

Date

RESOLUTION APPOINTING MARTINA GODBOLT TO THE ANTI-BULLYING ADVISORY BOARD TO PERFORM THE DUTIES AS PROVIDED FOR IN CHAPTER 283, AS ESTABLISHED BY MC-5392, ADOPTED ON JULY 12, 2022, AND AS AMENDED BY MC-5405, ADOPTED ON SEPTEMBER 13, 2022

WHEREAS, the City Council of the City of Camden has found that bullying can take place not only during school or at school functions but other times as well; and

WHEREAS, the City Council of the City of Camden believed that, based on the best interests of the residents of the City of Camden, an Anti-Bullying ordinance, Chapter 283, was needed and was thereby established by MC-5392, adopted on July 12, 2022; and

WHEREAS, Chapter 283 established an Anti-Bullying Advisory Board whose role includes the following:

283-8. Purpose and Duties.

1. To examine the best means to assist minors who are facing or have faced bullying in their neighborhoods.
2. To examine the types of bullying, which may include making threats, spreading rumors, conducting verbal attacks, making physical contact or other forms of verbal bullying, social bullying, cyber-bullying and physical bullying and the best means to address such bullying so that all our children can live safely and without fear within the City and its neighborhoods.
3. To possibly offer City programs for those minors who are facing bullying in their neighborhoods.
4. To examine the best means to disseminate pertinent information on bullying.
5. To make recommendations to the Mayor and City Council with regard to the Board's role and obligations pursuant to Chapter 283.

WHEREAS, chapter 283 provides that membership on the Advisory Board shall be as follows:

283-9. Membership.

1. Membership on the Anti-Bullying Advisory Board shall consist of twelve (12) members appointed by City Council as follows:
 - a. Four (4) members shall consist of student members; one student member from each Ward.
 - b. Five (5) members shall be adults who shall be members in one of the following fields: Mental Health Provider, Social Worker, Behavioral Health Therapist, Administrator- Education, Community Stakeholder, Business Owner or Operator, Juvenile Officer, Members of the faith-based community or those participating in Mentorship Programs.
 - c. One (1) member of Council to act as an advisor who shall be a non-voting member.
 - d. One (1) member of the Mayor's Office designated by the Mayor to act as an advisor who shall be a non-voting member.

283-10. Terms; vacancies; removals.

- A. The first term of the five (5) members of the Advisory Board as provided for in subsection 283-9(1) (b) above, shall be staggered with three (3) members serving for three (3) years and two (2) members serving for two (2) years. Thereafter, subsequent terms of the Advisory Board as provided for in subsection 283-9(1)(b) above, shall be for three (3) years. All other members of the Advisory Board as provided for in subsections 283-9(1) (a), (c) (d) and (e) shall be for one (1) year.

WHEREAS, Jannette Ramos, on July 28, 2023, based on her then upcoming appointment to the City Council of the City of Camden on August 1, 2023 to complete the term of Former Councilwoman Felisha Reyes, resigned from the Anti-Bullying Advisory Board; and

WHEREAS, the City Council of the City of Camden now seeks to appoint **Martina Godbolt** to replace Jannette Ramos as a member of the Anti-Bullying Advisory Board as provided for in subsection 283-9(1)(b); now therefore

BE IT RESOLVED, by the City Council of the City of Camden hereby appoints **Martina Godbolt** to the Anti-Bullying Advisory Board pursuant to subsection 283-9(1)(b).

BE IT FURTHER RESOLVED, by the City Council of the City of Camden that **Martina Godbolt** shall serve on the Anti-Bullying Advisory Board pursuant to subsection 283-9(1)(b) for a term of three (3) years.

BE IT FURTHER RESOLVED, that pursuant to N.J.S.A. 52:27BBB-23, a true copy of this Resolution shall be forwarded to the State Commissioner of Community Affairs, who shall have ten (10) days from the receipt thereof to veto this Resolution. All notices of veto shall be filed in the Office of the Municipal Clerk.

Date: March 12, 2024

The above has been reviewed and approved as to form

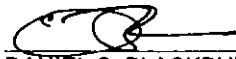

DANIEL S. BLACKBURN
City Attorney

ANGEL FUENTES
President, City Council

ATTEST: _____
LUIS PASTORIZA
Municipal Clerk



Camden City Council
RESOLUTION / ORDINANCE REQUEST FORM

DATE: February 16, 2024

Council Meeting Date: March 12, 2024

FROM: Councilperson

- Angel Fuentes, President
- Sheila Davis, Vice President, At-Large
- Arthur Barclay, 1st Ward
- Chris Collins, 2nd Ward

- Falio Leyba-Martinez, 3rd Ward
- Jannette Ramos, 4th Ward
- Nohemi G. Soria-Perez, At-Large

Action Requested:

RESOLUTION APPOINTING MARTINA GODBOLT TO THE ANTI-BULLYING ADVISORY BOARD TO PERFORM THE DUTIES AS PROVIDED FOR IN CHAPTER 283, AS ESTABLISHED BY MC-5392, ADOPTED ON JULY 12, 2022, AND AS AMENDED BY MC-5405, ADOPTED ON SEPTEMBER 13, 2022

****Please attach any supporting documents

Angel Fuentes/nfb

2/16/24

Signature of Councilperson

Date

R-7

ALL MEMBERS
3/12/2024

**RESOLUTION APPOINTING PATRICE BASSETT TO THE POSITION OF
DEPUTY MUNICIPAL CLERK FOR A TERM OF THREE (3) YEARS**

WHEREAS, in compliance with the Camden City Code, the City Council of the City of Camden now seeks to fill the vacant position of Deputy Municipal Clerk; and

WHEREAS, the City Council of the City of Camden is now appointing Patrice Bassett, a current member of the Municipal Clerk's Office, to fulfill this additional role; and

WHEREAS, Patrice Bassett's compensation will be the equivalent of her current combined earnings for her current positions as Records Manager and Deputy Registrar of Vital Statistics; and

WHEREAS, the annual salary of Patrice Bassett are to be adjusted in line with contractual steps and cost-of-living increases that Patrice Bassett would be due in her positions as Records Manager and Deputy Registrar of Vital Statistics; and

WHEREAS, this appointment is considered a lateral move and does not impose additional financial burden on the City of Camden; now therefore

BE IT RESOLVED, by the City Council of the City of Camden that Patrice Bassett is hereby appointed to the position of Deputy Municipal Clerk for a term of three (3) years.

BE IT FURTHER RESOLVED, in accordance with N.J.S.A. 52:27BBB-23, that a true copy of this Resolution shall be submitted to the State Commissioner of Community Affairs, who shall have ten (10) days to approve or veto it. Any notices of veto shall be filed in the Office of the Municipal Clerk.

Date: March 12, 2024

The above has been reviewed
approved as to form.



DANIEL BLACKBURN
City Attorney

ANGEL FUENTES
President, City Council

ATTEST: _____
LUIS PASTORIZA
Municipal Clerk

RESOLUTION RECOGNIZING ROSE GIUFFRE ON HER 100TH BIRTHDAY

WHEREAS, on September 18, 2024, Rose Giuffre will be attaining one-hundred (100) years of age; and

WHEREAS, Rose retired from the City of Camden after sixty-three (63) years of dedicated service in various positions -- Rose was initially hired through a New Deal program called the National Youth Administration, earning \$18 a month. Rose was ultimately hired as a full-time City employee on October 6, 1947 and subsequently rose through the ranks of the Municipal Clerk's Office from Clerk to Assistant Clerk before retiring; and

WHEREAS, Rose was always known as a "walking encyclopedia" with regard to all forms of City information whether it be legislative, administrative, political, and other information during her distinguished term of service to the City; and

WHEREAS, even to this day, Rose is seen by her colleagues as holding the unsurpassed record of sixty-three (63) years of dedicated, thoughtful, loyal, and professional employment with the City of Camden; and

WHEREAS, as with her incredible milestone of having worked for the City of Camden for an incredible record of sixty-three (63) years, Rose is now on the threshold of another phenomenal milestone in her life -- reaching her 100th birthday on September 18, 2024; and

WHEREAS, Rose has touched many people during her life -- among others -- family, friends, neighbors and co-workers; and

WHEREAS, it is an appropriate time to honor and commend Rose who has genuinely enriched the lives of the officials and residents of the City as well as her family, friends, neighbors and co-workers throughout her career and, perhaps more importantly -- during her incredible lifetime; now therefore

BE IT RESOLVED, that as Rose nears her 100th birthday this upcoming September, the City Council of the City of Camden hereby offers Rose Giuffre well-deserved recognition for the incredible and significant contributions she has made to the lives of the officials and residents of the City of Camden as well as her family, friends, neighbors and co-workers throughout her career and during her lifetime.

BE IT FURTHER RESOLVED, that pursuant to N.J.S.A. 52:27BBB-23, a true copy of this Resolution shall be forwarded to the State Commissioner of Community Affairs, who shall have ten (10) days from the receipt thereof to veto this Resolution. All notices of veto shall be filed in the Office of the Municipal Clerk.

Date: March 12, 2024

The above has been reviewed
and approved as to form



DANIEL S. BLACKBURN
City Attorney

ANGEL FUENTES
President, City Council

ATTEST: _____
LUIS PASTORIZA
Municipal Clerk



Camden City Council
RESOLUTION / ORDINANCE REQUEST FORM

DATE: March 4, 2024

Council Meeting Date: March 12, 2024

FROM: Councilperson

- | | |
|--|--|
| <input checked="" type="checkbox"/> Angel Fuentes, President | <input checked="" type="checkbox"/> Arthur Barclay, 1 st Ward |
| <input checked="" type="checkbox"/> Sheila Davis, Vice President, At-Large | <input checked="" type="checkbox"/> Christopher Collins, 2 nd Ward |
| <input checked="" type="checkbox"/> Nohemi Soria-Perez, At-Large | <input checked="" type="checkbox"/> Falio Leyba-Martinez, 3 rd Ward |
| | <input checked="" type="checkbox"/> Jannette Ramos, 4 th Ward |

Action Requested:

RESOLUTION REGONIZING ROSE GIUFFRE ON HER 100TH BIRTHDAY

***Please attach any supporting documents

ALL COUNCIL/118

3/4/2024

Signature of Councilperson

Date

R-9

DB:dh
03-12-24

RESOLUTION AUTHORIZING A CLOSED SESSION OF THE GOVERNING BODY TO DISCUSS PENDING LITIGATION

WHEREAS, The Open Public Meetings Act, N.J.S.A. 10:4-6, requires public meetings to be open to the public; however pursuant to N.J.S.A. 10:4-12, there are certain exceptions that permit an Executive Closed Session which would not be open to the public; and

WHEREAS, N.J.S.A. 10:4-12(b)(1) is one of The Open Public Meetings Act exceptions that permits an Executive Closed Session to discuss matters which are advisory, consultative or deliberative, and therefore confidential; now, therefore

BE IT RESOLVED, by the City Council of the City of Camden, that the governing body hereby authorizes an Executive Closed Session of the governing body on Tuesday, March 12, 2024 at 5:00 p.m. Furthermore, all appropriate steps as outlined by The Open Public Meetings Act, N.J.S.A. 10:4-6, et seq. will be followed and that notes of this session will be kept and that contents and discussions of this meeting will be revealed to the public as soon as practicable.

BE IT FURTHER RESOLVED, by the City Council of the City of Camden that, pursuant to the Open Public Meetings Act, N.J.S.A. 10: 4-6 et seq., all requirements for the holding of n Executive Closed Session will be complied with, including but not limited to, that notes will be taken of the Executive Closed Session which will be kept and maintained and also that discussions of the Executive Closed Session will be revealed to the public as soon as practicable.

BE IT FURTHER RESOLVED, that pursuant to N.J.S.A. 52:27BBB-23, a true copy of this Resolution shall be forwarded to the State Commissioner of Community Affairs, who shall have ten (10) days from the receipt thereof to veto this Resolution. All notices of veto shall be filed in the Office of the Municipal Clerk.

Date: March 12, 2024

The above has been reviewed and approved as to form.



DANIEL S. BLACKBURN
City Attorney

ANGEL FUENTES
President, City Council

ATTEST: _____
LUIS PASTORIZA
Municipal Clerk



CITY OF CAMDEN — CITY COUNCIL ACTION REQUEST FORM

COUNCIL MEETING DATE: MARCH 12, 2024

TO: City Council
FROM: Daniel S. Blackburn, City Attorney

TITLE OF ORDINANCE/RESOLUTION: RESOLUTION AUTHORIZING A CLOSED SESSION OF THE GOVERNING BODY TO DISCUSS PENDING LITIGATION

Point of Contact:	Daniel Blackburn	Law Dept.	X 7170	dablackb@ci.camden.nj.us
	Name	Department-Division-Bureau	Phone	Email

ENDORSEMENTS

	Recommend Approval (Y/N)	Signature	Date	Comments
Responsible				
Department Director				
Supporting Department Director (if necessary)				
Director of Grants Management				
Qualified Purchasing Agent				
Director of Finance				

Approved by:
Business Administrator

Signature	Date
-----------	------

Attachments (list and attach all available):

1. Waiver Request Form Attached for State DCA/DLGS Approval - (If applicable)¹
2. Certification of Funds²
3. Addition supporting documents.

"Walk-on" note: All walk-on legislation must be pre-approved by the Business Administrator. The Department Director and Contact Person are jointly responsible for delivering all necessary documents to the City Clerk for distribution at the Council Meeting.

Received by:
City Attorney

Signature	Date
-----------	------

¹ For Example: Form "A" - Request for approval of Employees Requiring Advice and Consent of Governing Body, Form "D" - Contract Request, Form "E" - Creation/Extension of Services, Form "G" - Grant Approval, Form "H" - Bond Ordinance or Contract Request, Form "I", "Best Price Insurance Contracting" Model Ordinance

² Mandatory for any financial commitment to the City or expenditure of City Funds.

EXECUTIVE SUMMARY

TITLE OF ORDINANCE/RESOLUTION: RESOLUTION AUTHORIZING A CLOSED SESSION OF THE GOVERNING BODY TO DISCUSS PENDING LITIGATION

FACTS/BACKGROUND: (Executive level details. Short concise bullets)

- N.J.S.A. 10:4-12(b)(1) is one of The Open Public Meetings Act exceptions that permits an Executive Closed Session to discuss matters which are advisory, consultative or deliberative, and therefore confidential

AMOUNT OF PROPOSED CONTRACT or TOTAL COST OF PROPOSAL:

IMPACT STATEMENT:

SUBJECT MATTER EXPERTS/ADVOCATES:

- Daniel Blackburn, City Attorney.
 - Attendance: (Y/N/Tentative). Confirmed?

COORDINATION:

Prepared by: Daniel S. Blackburn, City Attorney

X 7170

Name

Phone/Email

DB:dh
03-12-24

R-10

RESOLUTION AUTHORIZING THE SETTLEMENT OF LITIGATION

WHEREAS, there is now pending before the Superior Court of New Jersey, a case under Docket No. CAM-L-479-22, entitled Dalvi Shepard v. City of Camden in which the plaintiff seeks damages; and

WHEREAS, this matter has been reviewed and negotiated by and between the parties of this litigation and an agreement has been reached by and between these parties to settle the case with the City of Camden paying the total sum of TWO HUNDRED FIFTY THOUSAND DOLLARS (\$250,000.00); and

WHEREAS, in accordance with this settlement, the City of Camden will pay the total sum of TWO HUNDRED FIFTY THOUSAND DOLLARS (\$250,000.00); and

WHEREAS, the settlement of the within litigation is not an admission of liability on the part of the City of Camden but is made in recognition of the risks of litigation and in order to avoid the continued costs and expenses of litigating the within matter; and

WHEREAS, the specific terms of the settlement are set forth in the attached form of the Settlement Agreement; and

WHEREAS, Council has reviewed said settlement proposal and has determined that it is in the best interests of the City of Camden to settle the litigation in the aforesaid matter; and

WHEREAS, pursuant to the directive of the Division of Local Government Services, a certification has been attached hereto which certifies that the funds for this expenditure are available and appropriated under the trust account budget of the City of Camden under line item "T-35-900-101", and said certification has been signed by the Chief Financial Officer and approved as to form by the City Attorney; now, therefore

BE IT RESOLVED, by the City Council of the City of Camden that the proper officers are hereby authorized to adhere to the Settlement Agreement and to issue payment in the amount of TWO HUNDRED FIFTY THOUSAND DOLLARS (\$250,000.00), in the manner set forth in the Settlement Agreement.

BE IT FURTHER RESOLVED, that pursuant to N.J.S.A. 52:27BBB-23, a true copy of this Resolution shall be forwarded to the State Commissioner of Community Affairs, who shall have ten (10) days from the receipt thereof to veto this Resolution. All notices of veto shall be filed in the Office of the Municipal Clerk.

Date: March 12, 2024

The above has been reviewed and approved as to form.



DANIEL S. BLACKBURN
City Attorney

ANGEL FUENTES
President, City Council

ATTEST: _____
LUIS PASTORIZA
Municipal Clerk



CITY OF CAMDEN — CITY COUNCIL ACTION REQUEST FORM

COUNCIL MEETING DATE: **MARCH 12, 2024**

TO: City Council
FROM: Daniel S. Blackburn, City Attorney

TITLE OF ORDINANCE/RESOLUTION: Resolution Authorizing Settlement of Litigation

Point of Contact:	Daniel S. Blackburn	Law Department	856-757-7170	DaBlackb@ci.camden.nj.us
	Name	Department-Division-Bureau	Phone	Email

ENDORSEMENTS

	Recommend Approval (Y/N)	Signature	Date	Comments
Responsible Department Director	Y			
Supporting Department Director (if necessary)	N			
Director of Grants Management	N			
Qualified Purchasing Agent	N			
Director of Finance	Y			

Approved by:
Business Administrator

Signature

Date

Attachments (list and attach all available):

1. Additional supporting documents: Waiver D

"Walk-on" note: All walk-on legislation must be pre-approved by the Business Administrator. The Department Director and Contact Person are jointly responsible for delivering all necessary documents to the City Clerk for distribution at the Council Meeting.

Received by:
City Attorney

Signature

Date

EXECUTIVE SUMMARY

TITLE: RESOLUTION AUTHORIZING SETTLEMENT OF LITIGATION

FACTS/BACKGROUND: (Executive level details. Short concise bullets)

- TO BE DISCUSSED IN CLOSED SESSION.

AMOUNT OF PROPOSED CONTRACT or TOTAL COST OF PROPOSAL: \$250,000

IMPACT STATEMENT:

- TO BE DISCUSSED IN CLOSED SESSION

SUBJECT MATTER EXPERTS/ADVOCATES:

- Daniel Blackburn, City Attorney

COORDINATION:

Prepared by: Dionne Hicks-Giles

856-757-7175 dihicks@ci.camden.nj.us

Name

Phone/Email

**STATE OF NEW JERSEY
DEPARTMENT OF COMMUNITY AFFAIRS
DIVISION OF LOCAL GOVERNMENT SERVICES
CONTRACT REQUEST FORM**

This form must be filled out in its entirety and is intended to provide the Division with appropriate information to determine whether to approve a new or extended service. Please provide any additional information you believe will help the Division make an informed decision.

Municipality	City of Camden
--------------	----------------

Professional Service or EUS Type	Resolution Authorizing Settlement of Litigation
Name of Vendor	Plaintiff Dalvi Shepard
Purpose or Need for service:	Settlement of a pending bodily injury claim
Contract Award Amount	\$250,000
Term of Contract	
Temporary or Seasonal	n/a
Grant Funded (attach appropriate documentation allowing for service through grant funds)	n/a
Please explain the procurement process (i.e. bids, RFQ, competitive contracting, etc.)	
Were other proposals received? If so, please attach the names and amounts for each proposal received?	no

Please attach the RFP, evaluation memoranda or evaluation forms used to evaluate the vendors and a list of all bidders and the bid amounts associated with each bidder.

If the lowest bidder was not selected, please have the appropriate personnel sign the certification on page 2.

Mayor's Signature*

Date _____

Business Administrator/Manager Signature

Date _____

*For direct appointments of the Governing Body, Council President or at the discretion of the Director, the most senior member of the Governing Body may sign the waiver in lieu of the Mayor.

The Chief Financial Officer affirms that there is adequate funding available for this personnel action.

_____ Funding Source for this action

Chief Financial Officer Signature

I certify that the vendor selected is in compliance with the adopted Pay to Play Ordinance and that the vendor was notified of any restrictions with respect to campaign contributions.

Certifying Officer

Date _____

For LGS use only:

Approved

Denied

Director or Designee,
Division of Local Government Services

Date _____

Number Assigned _____

A-11

DB:dh
03-12-24

**RESOLUTION AUTHORIZING A FISCAL YEAR 2024
TAX AGREEMENT BETWEEN THE CITY OF CAMDEN
AND SOUTH JERSEY PORT CORPORATION**

WHEREAS, the City of Camden desires to enter into a Tax Agreement with the South Jersey Port Corporation for fiscal year 2024; and

WHEREAS, the South Jersey Port Corporation has agreed to pay the City of Camden Four Million Dollars (\$4,000,000.00) for fiscal year 2024 as a payment in lieu of taxes pursuant to N.J.S.A 12:11A-1 et seq.; and

WHEREAS, it is in the best interest of the City of Camden to enter into a Tax Agreement with South Jersey Port Corporation; now, therefore

BE IT RESOLVED, by the City Council of the City of Camden that it hereby authorizes the proper officials of the City of Camden to enter into a Tax Agreement with the South Jersey Port Corporation for fiscal year 2024, for the amount of Four Million Dollars (\$4,000,000.00).

BE IT FURTHER RESOLVED, that the City of Camden is authorized to accept Four Million Dollars (\$4,000,000.00) from the South Jersey Port Corporation pursuant to the within Tax Agreement.

BE IT FURTHER RESOLVED, that pursuant to N.J.S.A. 52:27BBB-23, a true copy of this Resolution shall be forwarded to the State Commissioner of Community Affairs, who shall have ten (10) days from the receipt thereof to veto this Resolution. All notices of veto shall be filed in the Office of the Municipal Clerk.

Date: March 12, 2024

The above has been reviewed and approved as to form.



DANIEL S. BLACKBURN
City Attorney

ANGEL FUENTES
President, City Council

ATTEST: _____
LUIS PASTORIZA
Municipal Clerk



CITY OF CAMDEN — CITY COUNCIL ACTION REQUEST FORM

COUNCIL MEETING DATE: MARCH 12, 2024

TO: City Council
FROM: Daniel S. Blackburn, City Attorney

TITLE OF ORDINANCE/RESOLUTION: RESOLUTION AUTHORIZING A FISCAL YEAR 2024 TAX AGREEMENT BETWEEN THE CITY OF CAMDEN AND SOUTH JERSEY PORT CORPORATION

Point of Contact:	Daniel Blackburn	Law Dept.	X 7170	dablackb@ci.camden.nj.us
	Name	Department-Division-Bureau	Phone	Email

ENDORSEMENTS

	Recommend Approval (Y/N)	Signature	Date	Comments
Responsible				
Department Director				
Supporting Department Director (if necessary)				
Director of Grants Management				
Qualified Purchasing Agent				
Director of Finance				

Approved by:
Business Administrator

Signature	Date
-----------	------

Attachments (list and attach all available):

1. Waiver Request Form Attached for State DCA/DLGS Approval - (If applicable)¹
2. Certification of Funds²
3. Addition supporting documents.

"Walk-on" note: All walk-on legislation must be pre-approved by the Business Administrator. The Department Director and Contact Person are jointly responsible for delivering all necessary documents to the City Clerk for distribution at the Council Meeting.

Received by:
City Attorney

	FEB 29 2024
Signature	Date

¹ For Example: Form "A" - Request for approval of Employees Requiring Advice and Consent of Governing Body, Form "D" - Contract Request, Form "E" - Creation/Extension of Services, Form "G" - Grant Approval, Form "H" - Bond Ordinance or Contract Request, Form "I", "Best Price Insurance Contracting" Model Ordinance
² Mandatory for any financial commitment to the City or expenditure of City Funds.

EXECUTIVE SUMMARY

**TITLE OF ORDINANCE/RESOLUTION: RESOLUTION AUTHORIZING A FISCAL YEAR 2024
TAX AGREEMENT BETWEEN THE CITY OF CAMDEN AND SOUTH JERSEY PORT CORPORATION**

FACTS/BACKGROUND: (Executive level details. Short concise bullets)

- South Jersey Port Corporation has agreed to pay the City of Camden a PILOT payment of Four Million Dollars (\$4,000,000.00) for fiscal year 2024

AMOUNT OF PROPOSED CONTRACT or TOTAL COST OF PROPOSAL:

IMPACT STATEMENT:

SUBJECT MATTER EXPERTS/ADVOCATES:

- Daniel Blackburn, City Attorney.
 - Attendance: (Y/N/Tentative). Confirmed?

COORDINATION:

Prepared by: Daniel S. Blackburn, City Attorney

X 7170

Name

Phone/Email

FISCAL YEAR 2024 TAX AGREEMENT

BETWEEN

CITY OF CAMDEN, NEW JERSEY

AND

SOUTH JERSEY PORT CORPORATION

THIS TAX AGREEMENT (hereinafter referred to as the "Tax Agreement") made this day of _____, 202__ by and between the **CITY OF CAMDEN**, a body corporate and politic of the State of New Jersey (hereinafter referred to as the "City") and the **SOUTH JERSEY PORT CORPORATION**, an Agency of the State of New Jersey (hereinafter referred to as the "Port Corporation").

WITNESSETH:

WHEREAS, pursuant to Chapter Sixty of the Laws of 1968 of the State of New Jersey, as amended (hereinafter referred to as the "Act"), the State of New Jersey ("State") granted the Port Corporation full power and authority to purchase, construct, lease and operate marine terminals within the South Jersey Port District, which includes the City; and

WHEREAS, the Port Corporation has, and will in the future, enter into various agreements, whereby they have, and will in the future, acquire title to real property within the City in furtherance of said purpose and in exercise of its powers; and

WHEREAS, the exercise of the power granted to the Port Corporation will be, in all respects, for the benefit of the people of the State of New Jersey; and

WHEREAS, the Fiscal Year 2023 Tax Agreement between the Port Corporation and the City expires on December 31, 2023; and

WHEREAS, the City's fiscal year 2024 begins January 1, 2024, and ends December 31, 2024; and

WHEREAS, the City and the Port Corporation wish to provide for a 2024 Tax Agreement based on the City's fiscal year; and

WHEREAS, the parties to this Tax Agreement have agreed to a fair and reasonable sum in order to compensate the City for said loss of tax revenues, and to enable it to provide for services to its citizens.

NOW, THEREFORE, THE PARTIES HERETO FOR THEMSELVES, THEIR SUCCESSORS AND ASSIGNS, MUTUALLY UNDERTAKE, COVENANT AND AGREE AS FOLLOWS:

Section 1. The Port Corporation agrees to pay to the City for the fiscal year 2024 the sum of four million dollars (\$4,000,000.00) and zero cents (hereinafter the "Pilot Payment"), and the City hereby agrees to accept the Pilot Payment, pursuant to the Act, in lieu of any and all City taxes and assessments on all real property now owned or hereafter acquired by the Port Corporation during the term of this Tax Agreement.

Section 2. The Pilot Payment shall be paid by the Port Corporation to the City not later than October 31, 2024, except as set forth hereafter.

Section 3. In consideration of Port Corporation's making the Pilot Payment for the fiscal year 2024, City hereby agrees to release the Port Corporation and waive City's rights to collect from Port Corporation any tax payments through and including December 31, 2024. Notwithstanding the above release, if the State of New Jersey decides to fund through appropriations any prior year(s)' payment in lieu of taxes, then the Port Corporation will

cooperate to pay such amount consistent with an agreement which will be negotiated at that time.

Section 4. City hereby agrees and acknowledges that the payment by Port Corporation of the Pilot Payment for the year(s) covered by this Tax Agreement is subject to and conditioned upon an appropriation from the Legislature of the State of New Jersey, and transmittal of such funds to the Port Corporation; and City further agrees that no liability shall occur to Port Corporation if such appropriation shall not be made, or if such funds shall not be transmitted to the Port Corporation.

Section 5. The Pilot Payment shall be devoted by the City solely to such purpose to which taxes may be applied, unless and until otherwise directed by the Laws of the State of New Jersey. Payments shall be made payable to the Treasurer of the City, and checks shall be made payable to his or her order.

Section 6. During the term of this Tax Agreement from the date of acquisition of each particular parcel of real property by the Port Corporation, and for so long thereafter as the Port Corporation shall own real property in the City, the City shall mark all said property exempt on its tax records with a notation that such entry is made pursuant to this Tax Agreement.

Section 7. The Port Corporation shall establish and maintain a special fund called the "South Jersey Port Corporation Tax Reserve Fund," hereinafter referred to as the "Fund", in which there shall be deposited: (a) monies appropriated therefore by the State of New Jersey as described in Section 8 below; (b) proceeds of bonds or notes required to be deposited therein by the terms of any contract between the Port Corporation and the bondholders or note holders; and (c) other monies deposited therein by the Port Corporation. Monies in the Fund shall be held and applied solely to the payment of tax payments which the Port Corporation is obligated to pay as

the same become due and payable and shall not be withdrawn therefrom if such withdrawal would reduce the amount in such fund to less than the Property Tax Reserve Fund, as defined in Section 20(b) of the Act.

Section 8. The obligations of the Port Corporation to make any tax payments from its funds or monies (other than from monies in the Fund) shall be at all times subject to prior use and application of funds and monies of the Port Corporation to provide for its operating and maintenance expenses and reserve therefore, and for the payment of principal, interest and retirement of bonds and reserves and securities therefore as provided in any contract with holders of its bonds pursuant to the Act.

Section 9. To assure the provision of the payment of the monies hereunder and funding of the Property Tax Reserve Fund, the Chairman of the Port Corporation shall annually make and deliver to the Governor, his certification stating the sum, if any, needed to provide in said Fund the amount of the property tax reserve as of said date. The Port Corporation shall not be required to make payments, and no interest shall accrue under the within agreement, until thirty (30) days from the time as there has been annually appropriated and paid to the Port Corporation for deposit in the said Fund such sums as certified by the Chairman of the Port Corporation pursuant to N.J.S.A. 12:11A-20b; or unless funds otherwise have been deposited in the said fund as provided by statute and referred to above; or unless the Port Corporation otherwise has funds available from the profits of its business operations, defined as net proceeds remaining after operating expenses and the other priority obligations under the Act and bond resolutions have been met.

Section 10. The term of this Tax Agreement shall be for the period commencing

January 1, 2024, and terminating December 31, 2024.

Section 11. It is expressly understood and agreed between the City and the Port Corporation that, by the execution of this Tax Agreement, and receipt of the sums provided for herein, the obligations of the Port Corporation and the City pursuant to Section 20(b) of the Act, N.J.S.A. 12:11A-20(b), relating to the issuance of bonds or notes of the Port Corporation, are hereby satisfied for the period through December 31, 2024.

Section 12. In the event that any of the real property in the City currently owned by the Port Corporation is conveyed during the term of this Tax Agreement by the Port Corporation to a non-exempt owner, or to the State or an agency thereof, or the United States Government or any agency thereof, or to the Delaware River Port Authority, the amount to be paid under this Tax Agreement by the Port Corporation shall be reduced. The amount of such reduction shall be the same percentage that the value of the property so conveyed is as to the total value of all the property based on the present assessment for that premises applied to the annual payment. In the event that the parties cannot agree as to the percentage of value, said percentage shall be determined by the average of two (2) appraisals, both of which shall be made by members of the Appraisal Institute. Each party shall be entitled to select one M.A.I. appraiser, and each party shall pay the appraiser selected by it.

Section 13. In consideration for the Pilot Payments, City hereby further agrees to discharge of record all outstanding tax liens or judgments which accrued during the Port Corporation's ownership of any property in the City.

Section 14. Neither the members of the Port Corporation, nor any individual officer or official of the Port Corporation or the City, nor any agent or employee of either of the parties

hereto, shall be charged personally by any of the others with any liability, nor held liable to either of the parties hereto under any terms, provisions or sections of this Tax Agreement, or because of its execution, attempted execution, or any breach hereof.

Section 15. This Tax Agreement constitutes the entire agreement between the parties hereto for the 2024 Fiscal Year. It is expressly understood and agreed that this Tax Agreement may not be altered, amended, modified, or otherwise changed in any respect or particular whatsoever except in writing duly executed by the authorized representative of the party or parties to be charged.

Section 16. This Tax Agreement shall be governed by, and construed in accordance with, the laws of the State of New Jersey. In the event any section or provision of this Tax Agreement, or the application of any such section or provision shall be held by a tribunal of competent jurisdiction to be contrary to law, the remaining sections or provisions of this Tax Agreement shall remain in full force and effect.

IN WITNESS WHEREOF, the parties have caused this Tax Agreement to be executed by their duly authorized representative as of the date and year first written above.

Attest:

CITY OF CAMDEN, NEW JERSEY

[SEAL]

By:

Attest:

SOUTH JERSEY PORT CORPORATION

[SEAL]

**By: ANDREW SAPORITO
EXECUTIVE DIRECTOR and CEO**

A-12

SE:dh
03-12-24

RESOLUTION AUTHORIZING AND RATIFYING AN EMERGENCY PROCUREMENT AND PAYMENT OF SAME TO THE ORIGINAL W. HARGROVE DEMOLITION CO. FOR THE EMERGENCY DEMOLITION OF 1169 CARL MILLER BLVD., BLOCK 453, LOT 131 AND IMPOSING A MUNICIPAL LIEN AGAINST THE PROPERTY

WHEREAS, on February 22, 2024, the City Construction Official inspected a building which was located at 1169 Carl Miller Blvd., Block 453, Lot 131; and

WHEREAS, upon inspection, the Construction Official determined that the building which was located at 1169 Carl Miller Blvd., Block 453, Lot 131 was an Unsafe Structure which constituted a danger to the health, safety and welfare of the residents of the City of Camden requiring prompt action; and

WHEREAS, on February 22, 2024, it was determined that the building which was located at 1169 Carl Miller Blvd., Block 453, Lot 131 required emergency demolition including the removal of all structures, contents, and other debris, whether above or below ground; and the final restoration and grading of the property; and

WHEREAS, the City reached out to The Original W. Hargrove Demolition, Inc., for bid of the emergency demolition of 1169 Carl Miller Blvd., Block 453, Lot 131, removal of all structures, contents and other debris, whether above or below ground; and the final restoration and grading of the property; and

WHEREAS, the City of Camden received a lump sum bid of SEVENTY-NINE THOUSAND DOLLARS (\$79,000.00) from The Original W. Hargrove Demolition, Inc., for the emergency demolition including the removal of all structures, contents and other debris, whether above or below ground; and the final restoration and grading of the property at 1169 Carl Miller Blvd., Block 453, Lot 131, Camden, NJ; and

WHEREAS, the City of Camden entered into a contract with The Original W. Hargrove Demolition, Inc. for SEVENTY-NINE THOUSAND DOLLARS (\$79,000.00) for the emergency demolition including the removal of all structures, contents and other debris, whether above or below ground; the final restoration and grading of 1169 Carl Miller Blvd., Block 453, Lot 131, Camden NJ; and

WHEREAS, pursuant to the directive of the Division of Local Government Services, a certification has been attached hereto which certifies that the funds for this expenditure are available and appropriated under the budget of the City of Camden, under line item "4-01-E4-605-901" and said certification has been signed by the Chief Financial Officer and approved as to form by the City Attorney; and

WHEREAS, the City of Camden is permitted by New Jersey law, N.J.S.A. 40:48 - 1.1 et seq. and the City of Camden Code to impose a municipal lien in the amount of SEVENTY-NINE THOUSAND DOLLARS (\$79,000.00) on the property at 1169 Carl Miller Blvd., Block 453, Lot 131, Camden, NJ or alternatively, to enforce the payment of SEVENTY-NINE THOUSAND DOLLARS (\$79,000.00), together with interest, as a debt of the owner of the property for the City's costs incurred for the emergency demolition including the removal of debris, final restoration, and grading of 1169 Carl Miller Blvd., Block 453, Lot 131, Camden, NJ; now therefore

BE IT RESOLVED, by the City Council of the City of Camden as follows:

1. The appropriate person in City of Camden shall have the authority to impose and record a lien in the amount of SEVENTY-NINE THOUSAND DOLLARS (\$79,000.00) on the property located at 1169 Carl Miller Blvd., Block 453, Lot

131, for the costs incurred for the emergency demolition, removal of debris, final restoration, and grading.

2. The municipal lien in the amount of SEVENTY-NINE THOUSAND DOLLARS (\$79,000.00) for the property located at 1169 Carl Miller Blvd., Block 453, Lot 131, Camden, NJ, shall remain on the property until the owner or other interested party satisfies this amount.
3. Interest and other costs shall accrue on the lien amount as allowed by law.
4. The City shall also have the authority pursuant to N.J.S.A. 40:48-1.1 and the Camden City Code to enforce the payment of the costs incurred by the City in the amount of SEVENTY-NINE THOUSAND DOLLARS (\$79,000.00) for the demolition including the removal of debris, final restoration, and grading at 1169 Carl Miller Blvd., Block 453, Lot 131, Camden, NJ, together with interest, as a debt of the owner of the property, by instituting an action at law for the collection of this sum.

BE IT FURTHER RESOLVED, that pursuant to N.J.S.A. 52:27BBB-23, a true copy of this Resolution shall be forwarded to the State Commissioner of Community Affairs, who shall have ten (10) days from the receipt thereof to veto this Resolution. All notices of veto shall be filed in the Office of the Municipal Clerk.

Date: March 12, 2024

The above has been reviewed
and approved as to form.



DANIELS. BLACKBURN
City Attorney

ANGEL FUENTES
President, City Council

ATTEST: _____
LUIS PASTORIZA
Municipal Clerk

CITY OF CAMDEN

CERTIFICATION AS TO THE AVAILABILITY OF FUNDS

I CERTIFY, DIRECTOR FOR THE FINANCE DEPARTMENT FOR THE CITY OF CAMDEN, THAT WITH RESPECT TO THE AWARD OF A CONTRACT OR EXPENDITURE OF FUNDS TO: THE ORIGINAL W. HARGROVE

THAT THE FUNDS ARE AVAILABLE AS OF THE DATE OF THIS RESOLUTION/CERTIFICATION, FROM ONE OF THE FOLLOWING:

- BUDGET APPROPRIATION: 4-01-E4-605-901
AMOUNT: \$ 79,000
- APPROPRIATION RESERVE:
AMOUNT: \$
- DEDICATED BY RIDER:
AMOUNT: \$
- RESERVE FOR STATE AND FEDERAL GRANT:
AMOUNT:\$
- CAPITAL ORDINANCE
AMOUNT: \$
- TRUST ACCOUNT:
AMOUNT: \$

DETERMINATION OF VALUE CERTIFICATION

I CERTIFY, AS CHIEF FINANCIAL OFFICER, THAT THE ANTICIPATED VALUE OF THE CONTRACT, OVER THE FULL LIFE, WILL BE: \$ 79,000.00

DESCRIPTION OF THE GOODS AND SERVICES TO BE PROCURED: RESOLUTION AUTHORIZING AND RATIFYING EMERGENCY PROCUREMENT AND PAYMENT OF SAME TO THE ORIGINAL W. HARGROVE DEMOLITION FOR 1169 CARL MILLER BLVD, BLOCK 453, LOT 131 AND IMPOSING A MUNICIPAL LEIN AGAINST THE PROPERTY

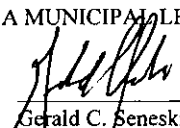

Gerald C. Seneski
Director of Finance
Date: 2/22



CITY OF CAMDEN — CITY COUNCIL ACTION REQUEST FORM

COUNCIL MEETING DATE: 03/12/2024

TO: City Council
FROM: Timothy J. Cunningham, Business Administrator

TITLE OF ORDINANCE/RESOLUTION: RESOLUTION AUTHORIZING AND RATIFYING EMERGENCY PROCUREMENT AND PAYMENT OF SAME TO THE ORIGINAL W. HARGROVE DEOMOLITION FOR 1169 CARL MILLER BLVD, BLOCK 453, LOT 131 AND IMPOSING A MUNICIPAL LIEN AGAINST THE PROPERTY

Point of Contact:	Lateefah Chandler	Admin-Purchasing	856-757-7475	lachandl@ci.camden.nj.us
	Name	Department- Division- Bureau	Phone	Email

ENDORSEMENTS

Recommend Approval (Y/N)	Signature	Date	Comments
--------------------------	-----------	------	----------

Responsible
 Department Director
 Supporting Department Director (if necessary)
 Director of Grants Management
 Qualified Purchasing Agent
 Director of Finance

Y *Lateefah Chandler* 2/22/2024
JH 2/22

Approved by:
Business Administrator

2-23-24

Signature

Date

Attachments (list and attach all available):

1. Waiver Request Form Attached for State DCA/DLGS Approval - (If applicable)¹
2. Certification of Funds²
3. Addition supporting documents.

"Walk-on" note: All walk-on legislation must be pre-approved by the Business Administrator. The Department Director and Contact Person are jointly responsible for delivering all necessary documents to the City Clerk for distribution at the Council Meeting.

Received by: City Attorney

Signature

Date

¹ For Example: Form "A" - Request for approval of Employees Requiring Advice and Consent of Governing Body, Form "D" - Contract Request, Form "E" - Creation/Extension of Services, Form "G" - Grant Approval, Form "H" - Bond Ordinance or Contract Request, Form "I", "Best Price Insurance Contracting" Model Ordinance

² Mandatory for any financial commitment to the City or expenditure of City Funds.

EXECUTIVE SUMMARY

TITLE OF ORDINANCE/RESOLUTION: RESOLUTION AUTHORIZING AND RATIFYING EMERGENCY PROCUREMENT AND PAYMENT OF SAME TO THE ORIGINAL W. HARGROVE DEMOLITION FOR 1169 CARL MILLER BLVD, BLOCK 453, LOT 131 AND IMPOSING A MUNICIPAL LIEN AGAINST THE PROPERTY

FACTS/BACKGROUND: (Executive level details. Short concise bullets)

- Ratify the emergency demolition and payment of same to The Original W. Hargrove Demolition Co., Inc., 1507 State Street, Camden NJ 08103 at 1169 Carl Miller Blvd, Block 453, Lot 1.
- On 2/22/2024 the Construction Office declared unsafe structure and imminent hazard due to major fire
- Received 3 quotes Hargrove (\$79,000), Winzinger (\$125,000) & Caravella (\$107,016)
- The City of Camden Code will impose a municipal lien against this property for the amount of the costs incurred by the City for the demolition and any additional expenses

AMOUNT OF PROPOSED CONTRACT or TOTAL COST OF PROPOSAL: \$79,000.00

PROCUREMENT PROCESS: N.J.S.A. 40A: 11-6 (Emergency)

APPROPRIATION NUMBER: 4-01-E4-605-901

IMPACT STATEMENT:

- ER Demolition work started 02/23/2024

SUBJECT MATTER EXPERTS/ADVOCATES:

- N/A

COORDINATION:

- N/A

Prepared by: LATEEAH CHANDLER

856-757-7159

Name

Phone/Email

**STATE OF NEW JERSEY
DEPARTMENT OF COMMUNITY AFFAIRS
DIVISION OF LOCAL GOVERNMENT SERVICES
CONTRACT REQUEST FORM**

This form must be filled out in its entirety and is intended to provide the Division with appropriate information to determine whether to approve a new or extended service. Please provide any additional information you believe will help the Division make an informed decision.

Municipality	CITY OF CAMDEN
Professional Service or EUS Type	N/A
Name of Vendor	THE ORIGINAL W HARGROVE DEMOLITION
Purpose or Need for service:	EMERGENCY DEMOLITION AT 1169 CARL MILLER BLVD, BLOCK 453, LOT 131
Contract Award Amount	\$79,000.00
Term of Contract	~5 DAYS
Temporary or Seasonal	N/A
Grant Funded (attach appropriate documentation allowing for service through grant funds)	NO
Please explain the procurement process (i.e. bids, RFQ, competitive contracting, etc.)	NJSA 40A:11-6
Were other proposals received? If so, please attach the names and amounts for each proposal received?	YES WINZINGER \$125,000.00 CARAVELLA \$107,016.00

Please attach the RFP, evaluation memoranda or evaluation forms used to evaluate the vendors and a list of all bidders and the bid amounts associated with each bidder.

If the lowest bidder was not selected, please have the appropriate personnel sign the certification on page 2.

Mayor's Signature*

Date _____

Business Administrator/Manager Signature

Date _____

*For direct appointments of the Governing Body, Council President or at the discretion of the Director, the most senior member of the Governing Body may sign the waiver in lieu of the Mayor.

The Financial Officer affirms that there is adequate funding available for this action.

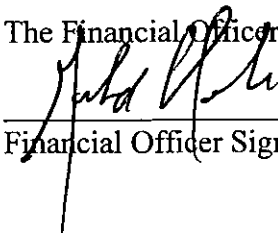

Financial Officer Signature

I certify that the vendor selected is in compliance with the adopted Pay to Play Ordinance and that the vendor was notified of any restrictions with respect to campaign contributions.

N/A Date _____
Certifying Officer

For LGS use only:

 Approved Denied

Date _____
Director or Designee,
Division of Local Government Services

Number Assigned _____

Fees for any additional charges not listed in this bid sheet are expressly not permitted under the contract.

I **HEREBY** submit and confirm this Bid Price Sheet, subject to all requirements and conditions stated in these bid specifications.

Company Name: "The Original" W. Hargrove Demolition Co Inc.

Bidder's Corporate Officer's Signature:

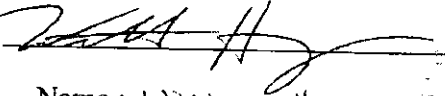

Name: William Hargrove

(print name)

Title: President

(print title)

Date: 2/22/2024

BID PRICE SHEET

EMERGENCY CONTRACT TO PROVIDE FOR THE DEMOLITION OF A RESIDENTIAL PROPERTY, THE REMOVAL OF ALL STRUCTURES, CONTENTS AND ALL OTHER DEBRIS, WHETHER ABOVE OR BELOW GROUND, AT 1169 CARL MILLER BLVD, BLOCK 453, LOT 131, FINAL RESTORATION AND GRADING OF THIS PROPERTY IN THE CITY OF CAMDEN

\$ 79,000.⁰⁰
TOTAL

Total Bid Amount in Words: Seventy Nine Thousand and
00/100 Dollars

NOTE: THE ABOVE LUMP SUM PAYMENTS MUST INCLUDE ALL COSTS, INCLUDING REMOVAL OF ALL DEBRIS, WHETHER ABOVE OR BELOW GROUND, ASBESTOS ABATEMENT, REMOVAL OF ABOVE GROUND OIL, PROPANE OR OTHER TYPES OF TANKS OR CONTAINERS, INCLUDING ABOVE GROUND OIL, PROPANE OR OTHER TYPES OF TANKS OR CONTAINERS LOCATED IN THE BASEMENT OF THE STRUCTURE(S) TO BE DEMOLISHED, ALL RESTORATION AND GRADING COSTS AND ALL OTHER COSTS.

PLEASE NOTE: GAS AND ELECTRIC SERVICES TO 1169 CARL MILLER BLVD, BLOCK 453, LOT 131, CAMDEN, NEW JERSEY HAVE BEEN DISCONNECTED BY PSE&G.

THE ABOVE LUMP SUM PAYMENTS MUST INCLUDE ALL COSTS ASSOCIATED WITH OTHER DISCONNECTION COSTS AS WELL AS DISCONNECTION OF APPURTENANT EQUIPMENT SUCH AS METERS, REGULATORS, AND GAUGES AND THE COORDINATION AND SCHEDULING THEREOF.

PLEASE NOTE: THE BIDDER WILL NOT BE RESPONSIBLE FOR WATER AND SEWER DISCONNECTS OR FOR THE COSTS FOR THESE WATER AND SEWER DISCONNECTS SINCE THE WATER AND SEWER DISCONNECT SERVICES ARE TO BE PROVIDED BY AMERICAN WATER.



CERTIFICATE OF ENVIRONMENTAL COMPLIANCE

Name of Contractor: "The Original" W. Hargrove Demolition Co. Inc.

I, William Hargrove, hereby agree to hold harmless the City of Camden, its successors and assignees, or its officials, officers, employees and agents, for any injuries to person or property incurred on loses suffered on account of the demolition of 1169 Carl Miller Boulevard, Camden

I certify upon inspection of the property that there is no asbestos or visible hazardous tanks. The contractor will not be responsible for the removal of subsurface tanks unless otherwise noted by the City of Camden. If either of these items are identified, they will be removed in accordance withal applicable federal, state, and local laws, ordinances, rules and regulations. Including, the New Jersey Department of Labor procedures, rules, and regulations, including providing appropriate documents, affidavits and/or certifications and also N.J.S.A 52:27D – 119 et. Seq.

Asbestos		Tanks	
Yes	No	Yes	No
<u>X</u>	<u> </u>	<u> </u>	<u>X</u>

By: [Signature]
William Hargrove, President.

Sworn and subscribed to before me
On this 22nd day of February, 2024

[Signature]
NOTARY PUBLIC
Kathy Jo Gipe
NOTARY PUBLIC
STATE OF NEW JERSEY
MY COMMISSION EXPIRES 03/26/2024

Lateefah Chandler

From: Lateefah Chandler
Sent: Thursday, February 22, 2024 1:42 PM
To: Timothy J. Cunningham; James Rizzo
Cc: Keith L. Walker; Dorri Brown; Gabriel Camacho; Keith L. Walker; Marytza Rodriquez; Victor Carstarphen; Jesse Flax
Subject: FW: EMERGENCY DEMOLITION 1169 CARL MILLER BLVD FIRE DAMAGE MAJOR COLLAPSE 02-22-2024
Attachments: 20240221_055816.jpg; 20240221_055446.jpg; 20240221_055502.jpg; 20240221_055749.jpg; Message from "RNP5838798034A4"

ER demo results 1169 Carl Miller Blvd

HARGROVE \$79,000.00
CARAVELLA \$107,016.00
WINZINGER \$125,00.00

If no issues, I will notify Hargrove to proceed

Thank you

Lateefah Chandler
Lateefah Chandler, QPA
Purchasing Agent
City of Camden
856-757-7475
856-541-9668 (fax)
Email: lachandl@ci.camden.nj.us

CONFIDENTIALITY NOTICE

The information contained in this communication from the City of Camden is privileged and confidential and is intended for the sole use of the persons or entities who are the addressees. If you are not an intended recipient of this e-mail, the dissemination, distribution, copying or use of the information it contains is strictly prohibited. If you have received this communication in error, please immediately contact the City of Camden at (856) 757-7475 to arrange for the return of this information.

-----Original Message-----

From: James Rizzo <JaRizzo@ci.camden.nj.us>
Sent: Thursday, February 22, 2024 7:08 AM
To: Christopher.green <Christopher.green@pseg.com>; David Krug <dalvin.krug@amwater.com>; Dorri Brown <DoBrown@ci.camden.nj.us>; Edwin Guzman <EdGuzman@ci.camden.nj.us>; Gabe Rodriguez CCP <rodriguez12@camdencountypd.org>; Gabriel Camacho <GaCamach@ci.camden.nj.us>; Gary Brooks <gary.brooks@amwater.com>; Howard McCoach <HoMcCoac@ci.camden.nj.us>; James Rizzo <JaRizzo@ci.camden.nj.us>; Jesse Flax <JeFlax@ci.camden.nj.us>; Keith L. Walker <KeWalker@ci.camden.nj.us>; Lateefah Chandler <LaChandl@ci.camden.nj.us>; Marc Riondino <MaRiondi@ci.camden.nj.us>; Steven.Rodriguez <Steven.Rodriguez@amwater.com>; Timothy J. Cunningham <TiCunnin@ci.camden.nj.us>; Victor Carstarphen <ViCarsta@ci.camden.nj.us>



CITY OF CAMDEN
DEPARTMENT OF CODE ENFORCEMENT
BUILDING BUREAU

EMERGENCY DEMOLITION

To: Keith Walker, Director of Department of Public Works

From: JAMES R RIZZO, Construction Official

Date: Thursday, February 22, 2024

SITE: 1169 CARL MILLER BLVD

Owner BROWN, JERRY D
SAME
CAMDEN, NJ 08104

I hereby certify that all necessary steps required pursuant to UCC 5:23-2.32 have been taken by the Building Bureau prior to issuing this demolition memorandum for above referenced property.
Please process accordingly.

Signed: 
JAMES R RIZZO, Construction Official

Signed: 
Building Sub code Official

COMMENTS ————— **STANDALONE BLDG. NO STUCCO**

EMERGENCY-DEMOLITION
02/22/2024
DEMOLITION START 02/23/24

EMERGENCY-DEMOLITION
02/22/2024
DEMOLITION START 02/23/24

PUBLIC SERVICE ELECTRIC & GAS COMPANY
PO BOX 1023,
CRANFORD, NJ 07016-1023
Phone: 800-817-3366 Fax: 908-497-1878
E-mail: demolition@pseg.com

PSE&G SERVICE REMOVAL REQUEST FORM

Office Use Only: Project # _____ G1# _____ E1# _____

REVIEW APPLICATION INSTRUCTIONS BEFORE COMPLETING

COMPANY NAME *If applicable*: CITY OF CAMDEN

OWNER'S NAME: BROWN, JERRY D

OWNER'S AUTHORIZED AGENT name and title: N/A

SERVICE ADDRESS: 1169 CARL MILLER BLVD TOWN: CAMDEN
(OF BLDG TO BE DEMOLISHED)

CROSS STREET: MT EPHRAIM AVE

OWNER'S MAILING ADDRESS: SAME _____-08104

(This is where the service removal completion letter will be sent)

OWNER'S PRIMARY RESIDENCE? (CIRCLE ONE) YES (NO)

PREMISE VACANT? (CIRCLE ONE) (YES) NO

IMPORTANT: APPLICATION WILL NOT BE ACCEPTED UNTIL APPLICANT HAS TAKEN OWNERSHIP AND PROPERTY IS VACANT.

PROJECT CONTACT: JAMES R RIZZO FAX: JARIZZO@CI.CAMDEN.NJ.US

PRIMARY PHONE: 609-319-9883 (OR E-MAIL) ALTERNATE PHONE: N/A

METER NUMBERS: Gas N/A Electric N/A

TYPE AND NUMBER OF STRUCTURES TO BE DEMOLISHED: N/A

DOES THE STRUCTURE TO BE DEMOLISHED HAVE MORE THAN ONE ADDRESS? **A separate form is required for each address.**

PSE&G LIGHTING TO BE REMOVED? (CIRCLE ONE) YES (NO)

PSE&G POLES TO BE REMOVED? (CIRCLE ONE) YES (NO)

POLE#(S) **required**: _____

OTHER PSE&G EQUIPMENT?(TRANSFORMER, SWITCHGEAR, ETC.) YES NO

TYPE OF ELECTRICAL SERVICE: (CIRCLE ONE) (OVERHEAD) UNDERGROUND

ARE YOU AWARE OF ANY ENVIRONMENTAL ISSUES AT THIS SITE? YES NO

PLEASE EXPLAIN _____

TYPE OF STRUCTURE TO BE BUILT AFTER DEMOLITION: N/A

APPROXIMATE DATE OF RECONSTRUCTION: N/A

SIGNATURE:  PRINT NAME: JAMES R RIZZO

DATE: 02/22/2024

BY SUBMITTING THIS APPLICATION YOU ARE CERTIFYING THAT YOU ARE AUTHORIZED TO REQUEST REMOVAL OF ELECTRIC AND GAS SERVICES AT THE PROPERTY SPECIFIED AND THAT PREMISE IS VACANT. Proof of ownership required at time of application. Please refer to the instructions sent with this form for list of acceptable forms of proof.

Block: 453	Outside Lien	Sp Charges	Notes Exist						
Lot: 131	Tax Sale								
Qualifier:	FORCLOSURE-SEE NOTES								
Owner: BROWN, JERRY H									
Prop Loc: 1169 CARL KILLER BLVD	Account ID: 99998881	Tax Bill	PTR Form						
General	Assessed Value	Additional	Billing	Deductions	Balance	All Charges	Add/Ornit	Notes	
Owner Street 1: 1169 CARL KILLER BLVD	Additional Lot 1:	Additional Lot 2:	Property Class: 4A	Parcel Key:	Unpaid Interest: .86	Vendor:	User Mags: 09	Exclude from Tax Sale:	Online Payment Restrictions: None
Street 2:	City/ST: DUNELN, NJ	Country:	Phone: () -	Email:	Bank Code:	Municipal Lien:	Assignment:	Bankruptcy:	APR 2:
Zip: 08164-7649						Outside Lien:	Sp Charges:	Install. Plan:	Auto-Pay:

1169 CARL MILLER FIRE 2-21-2024 MPC



1169 CARL MILLER FIRE 2-21-2024 MPC



1169 CARL MILLER FIRE 2-21-2024 MPC



CITY OF CAMDEN

EMERGENCY CONTRACT TO PROVIDE FOR THE DEMOLITION OF A RESIDENTIAL PROPERTY, THE REMOVAL OF ALL STRUCTURES, CONTENTS AND ALL OTHER DEBRIS, WHETHER ABOVE OR BELOW GROUND, AT 1169 CARL MILLER BLVD, BLOCK 453, LOT 131, FINAL RESTORATION AND GRADING OF THIS PROPERTY IN THE CITY OF CAMDEN

This Emergency Demolition is encompassed by the Standard City Demolition Specifications, which are incorporated by reference and made a part hereto, and the following, special provisions.

On February 22, 2024, the City of Camden Construction Official conducted an inspection of the structure at 1169 Carl Miller Blvd, Block 453, Lot 131, and determined that it is an unsafe structure and imminent hazard: major fire. These unsafe conditions make this structure extremely dangerous to the residents. The Construction Official provided the owner until February 22, 2024 to demolish the structure or correct the unsafe conditions. The owner has failed to do so and the Construction Official has determined that the building structure must be promptly demolished.

By this emergency quote, the City of Camden is seeking one (1) contractor to provide for the demolition of the residential property at 1169 Carl Miller Blvd, Block 453, Lot 131, the removal of all structures, contents and all other debris, whether above or below ground, and final restoration and grading of the property in the City of Camden.

The Contractor must respond by no later than 12:00 pm on February 22, 2024. The Purchasing Bureau will contact the successful vendor by telephone/email with notice to proceed.

Contractor must secure the property immediately after being notified of the award on February 22, 2024 for public safety. A Portable six-foot (6') metal cyclone fence (**hard fencing**) must be erected around the pedestrian walkway(s) of the structure(s) to be demolished. (**NO EXCEPTIONS**). **Any immediate hazards [falling debris, etc.] that has the potential to fall outside of the fencing must be corrected at that time.** **Contractor must begin demolition by 10:00 am on Friday, February 23, 2024.**

Contractor shall ensure that dust be kept to a minimum by spraying the site with water during the demolition. Sidewalks should be made passable and left broom clean daily during the course of your demolition operations.

All Contractor signage shall be removed from the worksite at the time the job is completed. This requirement is a condition prior to receipt of final payment.

PLEASE BE ADVISED

- **EMERGENCY CONTRACT TO PROVIDE FOR THE DEMOLITION OF A RESIDENTIAL PROPERTY, THE REMOVAL OF ALL STRUCTURES, CONTENTS AND ALL OTHER DEBRIS, WHETHER ABOVE OR BELOW GROUND, AT 1169 CARL MILLER BLVD, BLOCK 453, LOT 131, FINAL RESTORATION AND GRADING OF THIS PROPERTY IN THE CITY OF CAMDEN**
- **Any tanks or containers on the property must be removed from the property and such removal costs shall be included in the bid price sheet. All such removal work shall be done in accordance with and comply with all applicable federal, state, and local laws, ordinances, rules and regulations. Furthermore, the Contractor must comply with the New Jersey Department of Labor procedures, rules, and regulations, including providing appropriate documents, affidavits and/or certifications.**
- **Contractor must secure subject site with sufficient and appropriate security fencing while the Contractor is performing the emergency demolition in order to adequately protect the public health, safety and welfare of the citizens of the City.**
- **All costs for asbestos and tank and/or container removals must be included in the Bid Price Sheet's Lump Sum Payments. The City of Camden will not pay any additional costs for these removals.**
- **AWARD WILL BE BASED ON THE TOTAL AMOUNT OF THE QUOTE.**

***EXCEPTION:** If asbestos or other contamination is verified, then the demolition time schedule is referred to the Construction Official.

A Certificate of Environmental Compliance and Hold Harmless Agreement issued by the City Construction Official are attached to this fax; they must be completed and returned with the Proposal prior to any award and demolition work. Return of the Certificates is MANDATORY; otherwise said proposal will be rejected. The worksite must remain secure until project is properly abated.

The dollar amount for all demolition quotes must be submitted in two written versions as per example.

Example: "Seven thousand five hundred dollars" and \$ 7,500.00

PLEASE NOTE: In the event of a tie for emergency demolition request, the determining factor will be awarded to the contractor who submits their proposal the earliest

BID PRICE SHEET

EMERGENCY CONTRACT TO PROVIDE FOR THE DEMOLITION OF A RESIDENTIAL PROPERTY, THE REMOVAL OF ALL STRUCTURES, CONTENTS AND ALL OTHER DEBRIS, WHETHER ABOVE OR BELOW GROUND, AT 1169 CARL MILLER BLVD, BLOCK 453, LOT 131, FINAL RESTORATION AND GRADING OF THIS PROPERTY IN THE CITY OF CAMDEN

\$ _____
TOTAL

Total Bid Amount in Words: _____

NOTE: THE ABOVE LUMP SUM PAYMENTS MUST INCLUDE ALL COSTS, INCLUDING REMOVAL OF ALL DEBRIS, WHETHER ABOVE OR BELOW GROUND, ASBESTOS ABATEMENT, REMOVAL OF ABOVE GROUND OIL, PROPANE OR OTHER TYPES OF TANKS OR CONTAINERS, INCLUDING ABOVE GROUND OIL, PROPANE OR OTHER TYPES OF TANKS OR CONTAINERS LOCATED IN THE BASEMENT OF THE STRUCTURE(S) TO BE DEMOLISHED, ALL RESTORATION AND GRADING COSTS AND ALL OTHER COSTS.

PLEASE NOTE: GAS AND ELECTRIC SERVICES TO 1169 CARL MILLER BLVD, BLOCK 453, LOT 131, CAMDEN, NEW JERSEY HAVE BEEN DISCONNECTED BY PSE&G.

THE ABOVE LUMP SUM PAYMENTS MUST INCLUDE ALL COSTS ASSOCIATED WITH OTHER DISCONNECTION COSTS AS WELL AS DISCONNECTION OF APPURTENANT EQUIPMENT SUCH AS METERS, REGULATORS, AND GAUGES AND THE COORDINATION AND SCHEDULING THEREOF.

PLEASE NOTE: THE BIDDER WILL NOT BE RESPONSIBLE FOR WATER AND SEWER DISCONNECTS OR FOR THE COSTS FOR THESE WATER AND SEWER DISCONNECTS SINCE THE WATER AND SEWER DISCONNECT SERVICES ARE TO BE PROVIDED BY AMERICAN WATER.

Fees for any additional charges not listed in this bid sheet are expressly not permitted under the contract.

I HEREBY submit and confirm this Bid Price Sheet, subject to all requirements and conditions stated in these bid specifications.

Company Name: _____

Bidder's Corporate Officer's Signature: _____

Name : _____ (

print name)

Title: _____

(print title)

Date: _____



CERTIFICATE OF ENVIRONMENTAL COMPLIANCE

Name of Contractor: _____

I, _____, hereby agree to hold harmless the City of Camden, its successors and assignees, or its officials, officers, employees and agents, for any injuries to person or property incurred on loses suffered on account of the demolition of

I certify upon inspection of the property that there is no asbestos or visible hazardous tanks. The contractor will not be responsible for the removal of subsurface tanks unless otherwise noted by the City of Camden. If either of these items are identified, they will be removed in accordance withal applicable federal, state, and local laws, ordinances, rules and regulations. Including, the New Jersey Department of Labor procedures, rules, and regulations, including providing appropriate documents, affidavits and/or certifications and also N.J.S.A 52:27D – 119 et. Seq.

Asbestos		Tanks	
Yes	No	Yes	No
_____	_____	_____	_____

By: _____

Sworn and subscribed to before me
On this _____ day of _____ 2024

NOTARY PUBLIC

BID PRICE SHEET

EMERGENCY CONTRACT TO PROVIDE FOR THE DEMOLITION OF A RESIDENTIAL PROPERTY, THE REMOVAL OF ALL STRUCTURES, CONTENTS AND ALL OTHER DEBRIS, WHETHER ABOVE OR BELOW GROUND, AT 1169 CARL MILLER BLVD, BLOCK 453, LOT 131, FINAL RESTORATION AND GRADING OF THIS PROPERTY IN THE CITY OF CAMDEN

\$ 107,016.00
TOTAL

Total Bid Amount in Words: One Hundred Seven Thousand Sixteen Dollars and 00/100

NOTE: THE ABOVE LUMP SUM PAYMENTS MUST INCLUDE ALL COSTS, INCLUDING REMOVAL OF ALL DEBRIS, WHETHER ABOVE OR BELOW GROUND, ASBESTOS ABATEMENT, REMOVAL OF ABOVE GROUND OIL, PROPANE OR OTHER TYPES OF TANKS OR CONTAINERS, INCLUDING ABOVE GROUND OIL, PROPANE OR OTHER TYPES OF TANKS OR CONTAINERS LOCATED IN THE BASEMENT OF THE STRUCTURE(S) TO BE DEMOLISHED, ALL RESTORATION AND GRADING COSTS AND ALL OTHER COSTS.

PLEASE NOTE: GAS AND ELECTRIC SERVICES TO 1169 CARL MILLER BLVD, BLOCK 453, LOT 131, CAMDEN, NEW JERSEY HAVE BEEN DISCONNECTED BY PSE&G.

THE ABOVE LUMP SUM PAYMENTS MUST INCLUDE ALL COSTS ASSOCIATED WITH OTHER DISCONNECTION COSTS AS WELL AS DISCONNECTION OF APPURTENANT EQUIPMENT SUCH AS METERS, REGULATORS, AND GAUGES AND THE COORDINATION AND SCHEDULING THEREOF.

PLEASE NOTE: THE BIDDER WILL NOT BE RESPONSIBLE FOR WATER AND SEWER DISCONNECTS OR FOR THE COSTS FOR THESE WATER AND SEWER DISCONNECTS SINCE THE WATER AND SEWER DISCONNECT SERVICES ARE TO BE PROVIDED BY AMERICAN WATER.

Fees for any additional charges not listed in this bid sheet are expressly not permitted under the contract.

I **HEREBY** submit and confirm this Bid Price Sheet, subject to all requirements and conditions stated in these bid specifications.

Company Name: Caravello Demolition, Inc.

Bidder's Corporate Officer's Signature: John Caravello

(print name)

Name: John Caravello

Title: President

(print title)

Date: 2-22-2024



CERTIFICATE OF ENVIRONMENTAL COMPLIANCE

Name of Contractor: Caravello Demolition, Inc.

I, John Caravello, hereby agree to hold harmless the City of Camden, its successors and assignees, or its officials, officers, employees and agents, for any injuries to person or property incurred on losses suffered on account of the demolition of Roof truss structure at 1169 Carl Miller Blvd.

I certify upon inspection of the property that there is no asbestos or visible hazardous tanks. The contractor will not be responsible for the removal of subsurface tanks unless otherwise noted by the City of Camden. If either of these items are identified, they will be removed in accordance with applicable federal, state, and local laws, ordinances, rules and regulations. Including, the New Jersey Department of Labor procedures, rules, and regulations, including providing appropriate documents, affidavits and/or certifications and also N.J.S.A 52:27D - 119 et. Seq.

Asbestos

Tanks

Yes No
XX _____

Yes No
_____ K

By: John Caravello

Sworn and subscribed to before me
On this 22nd day of February 2024

Anna M. Bastos
NOTARY PUBLIC

ANNA M. BASTOS
NOTARY PUBLIC OF NEW JERSEY
Commission # 2322830
My Commission Expires 12/13/2024

WINZINGER, INC.
P.O. BOX 537, 1704 MARNE HWY.
HAINESPORT, NJ 08036
(609)267-8600

BID PRICE SHEET

EMERGENCY CONTRACT TO PROVIDE FOR THE DEMOLITION OF A RESIDENTIAL PROPERTY, THE REMOVAL OF ALL STRUCTURES, CONTENTS AND ALL OTHER DEBRIS, WHETHER ABOVE OR BELOW GROUND, AT 1169 CARL MILLER BLVD, BLOCK 453, LOT 131, FINAL RESTORATION AND GRADING OF THIS PROPERTY IN THE CITY OF CAMDEN

\$ 125,000.⁰⁰
TOTAL

Total Bid Amount in Words: _____

One Hundred Twenty Five Thousand Dollars and ^{NO} CENTS

NOTE: THE ABOVE LUMP SUM PAYMENTS MUST INCLUDE ALL COSTS, INCLUDING REMOVAL OF ALL DEBRIS, WHETHER ABOVE OR BELOW GROUND, ASBESTOS ABATEMENT, REMOVAL OF ABOVE GROUND OIL, PROPANE OR OTHER TYPES OF TANKS OR CONTAINERS, INCLUDING ABOVE GROUND OIL, PROPANE OR OTHER TYPES OF TANKS OR CONTAINERS LOCATED IN THE BASEMENT OF THE STRUCTURE(S) TO BE DEMOLISHED, ALL RESTORATION AND GRADING COSTS AND ALL OTHER COSTS.

PLEASE NOTE: GAS AND ELECTRIC SERVICES TO 1169 CARL MILLER BLVD, BLOCK 453, LOT 131, CAMDEN, NEW JERSEY HAVE BEEN DISCONNECTED BY PSE&G.

THE ABOVE LUMP SUM PAYMENTS MUST INCLUDE ALL COSTS ASSOCIATED WITH OTHER DISCONNECTION COSTS AS WELL AS DISCONNECTION OF APPURTENANT EQUIPMENT SUCH AS METERS, REGULATORS, AND GAUGES AND THE COORDINATION AND SCHEDULING THEREOF.

PLEASE NOTE: THE BIDDER WILL NOT BE RESPONSIBLE FOR WATER AND SEWER DISCONNECTS OR FOR THE COSTS FOR THESE WATER AND SEWER DISCONNECTS SINCE THE WATER AND SEWER DISCONNECT SERVICES ARE TO BE PROVIDED BY AMERICAN WATER.

Fees for any additional charges not listed in this bid sheet are expressly not permitted under the contract.

I **HEREBY** submit and confirm this Bid Price Sheet, subject to all requirements and conditions stated in these bid specifications.

Company Name: WINZINGER, INC.

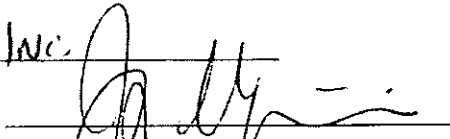
Bidder's Corporate Officer's Signature: 

Name: Jean Winzinger

print name)

Title: President

(print title)

Date: 2/22/24



CERTIFICATE OF ENVIRONMENTAL COMPLIANCE

Name of Contractor: WINZINGER, INC.

I, DAWN WINZINGER, hereby agree to hold harmless the City of Camden, its successors and assignees, or its officials, officers, employees and agents, for any injuries to person or property incurred on losses suffered on account of the demolition of 1112 CAL MINER BLVD

I certify upon inspection of the property that there is no asbestos or visible hazardous tanks. The contractor will not be responsible for the removal of subsurface tanks unless otherwise noted by the City of Camden. If either of these items are identified, they will be removed in accordance withal applicable federal, state, and local laws, ordinances, rules and regulations. Including, the New Jersey Department of Labor procedures, rules, and regulations, including providing appropriate documents, affidavits and/or certifications and also N.J.S.A 52:27D – 119 et. Seq.

Asbestos

Tanks

Yes

No

Yes

No

By: [Signature]

Sworn and subscribed to before me

On this 22 day of February 2024

[Signature]
NOTARY PUBLIC

WILLIAM K. CHALLENGER
NOTARY PUBLIC OF NEW JERSEY
Commission # 2334891
My Commission Expires 02/20/2025

R-13

SE:dh
03-12-24

RESOLUTION AUTHORIZING THE CITY TO RECEIVE PROPOSALS FOR CONSULTING SERVICES FOR A STREET LIGHT AUDIT

WHEREAS, the City of Camden has a need to conduct an Audit of the Street Lights; and

WHEREAS, the City of Camden desires to initiate the competitive contracting process to solicit proposals for Consulting Services for the Street Light Audit; and

WHEREAS, pursuant to N.J.S.A. 40A:11-4.3, in order to initiate the competitive contracting process, Council of the City of Camden must pass a resolution authorizing the use of the competitive contracting; and

WHEREAS, pursuant to N.J.S.A. 40A:11-4.1m, the Department of Community Affairs Division of Local Government Services must approve the City's use of the competitive contracting process to solicit proposals for Consulting Services; now therefore

BE IT RESOLVED, by the Council of the City of Camden that the City is hereby authorized to initiate the competitive contracting process to solicit proposals for Consulting Services for a Street Light Audit.

BE IT FURTHER RESOLVED, that pursuant to N.J.S.A. 52:27BBB-23, a true copy of this Resolution shall be forwarded to the State Commissioner of Community Affairs, who shall have ten (10) days from the receipt thereof to veto this Resolution. All notices of veto shall be filed in the Office of the Municipal Clerk.

Date: March 12, 2024

The above has been reviewed and approved as to form.

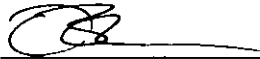

DANIEL S. BLACKBURN
City Attorney

ANGEL FUENTES
President, City Council

ATTEST: _____
LUIS PASTORIZA
Municipal Clerk



CITY OF CAMDEN — CITY COUNCIL ACTION REQUEST FORM

COUNCIL MEETING DATE: 03/12/2024

TO: City Council
FROM: Timothy J. Cunningham, Business Administrator

TITLE OF ORDINANCE/RESOLUTION: RESOLUTION AUTHORIZING THE CITY OF CAMDEN TO UTILIZE THE COMPETITIVE CONTRACTING PROCESS TO RECEIVE PROPOSALS FOR CONSULTING SERVICES FOR A STREET LIGHT AUDIT

Point of Contact:	Lateefah Chandler	Admin-Purchasing	856-757-7475	lachandl@ci.camden.nj.us
	Name	Department-Division-Bureau	Phone	Email

ENDORSEMENTS

Responsible	Recommend Approval (Y/N)	Signature	Date	Comments
Department Director Supporting Department Director (if necessary) Grants Management Qualified Purchasing Agent Director of Finance	Y		2/21/2024	

Approved by: _____
 Business Administrator 2/22
Signature Date

Attachments (list and attach all available):

1. Waiver Request Form Attached for State DCA/DLGS Approval - (If applicable)¹
2. Certification of Funds²
3. Addition supporting documents.

“Walk-on” note: All walk-on legislation must be pre-approved by the Business Administrator. The Department Director and Contact Person are jointly responsible for delivering all necessary documents to the City Clerk for distribution at the Council Meeting.

Received by: _____
 City Attorney Date
Signature

FEB 29 2024

¹ For Example: Form “A” - Request for approval of Employees Requiring Advice and Consent of Governing Body, Form “D” - Contract Request, Form “E” - Creation/Extension of Services, Form “G” - Grant Approval, Form “H” - Bond Ordinance or Contract Request, Form “I”, “Best Price Insurance Contracting” Model Ordinance

² Mandatory for any financial commitment to the City or expenditure of City Funds.

EXECUTIVE SUMMARY

TITLE OF ORDINANCE/RESOLUTION: RESOLUTION AUTHORIZING THE CITY OF CAMDEN TO UTILIZE THE COMPETITIVE CONTRACTING PROCESS TO RECEIVE PROPOSALS FOR CONSULTING SERVICES FOR A STREET LIGHT AUDIT

FACTS/BACKGROUND: (Executive level details. Short concise bullets)

- Per N.J.S.A 40A:11-4.3(a), governing body approval is required before utilizing the competitive contracting process for services enumerated in N.J.S.A 40A:11-4.1
- N.J.S.A 40A:11-4.1 (m) Consulting Services is an approved specialized goods and services for which competitive contracting can be used.

AMOUNT OF PROPOSED CONTRACT or TOTAL COST OF PROPOSAL: N/A

APPROPRIATION NUMBER: N/A

PROCUREMENT: N/A

IMPACT STATEMENT:

- N/A

SUBJECT MATTER EXPERTS/ADVOCATES:

- N/A

COORDINATION:

- N/A

Prepared by: LATEEAH CHANDLER

856-757-7159

Name

Phone/Email

**STATE OF NEW JERSEY
DEPARTMENT OF COMMUNITY AFFAIRS
DIVISION OF LOCAL GOVERNMENT SERVICES
CONTRACT REQUEST FORM**

This form must be filled out in its entirety and is intended to provide the Division with appropriate information to determine whether to approve a new or extended service. Please provide any additional information you believe will help the Division make an informed decision.

Municipality	CITY OF CAMDEN
Professional Service or EUS Type	N/A
Name of Vendor	N/A
Purpose or Need for service:	COMPETITIVE CONTRACTING FOR CONSULTING SERVICES
Contract Award Amount	N/A
Term of Contract	N/A
Temporary or Seasonal	N/A
Grant Funded (attach appropriate documentation allowing for service through grant funds)	N/A
Please explain the procurement process (i.e. bids, RFQ, competitive contracting, etc.)	NJSA 40A:11-4.1 ET SEQ
Were other proposals received? If so, please attach the names and amounts for each proposal received?	N/A

Please attach the RFP, evaluation memoranda or evaluation forms used to evaluate the vendors and a list of all bidders and the bid amounts associated with each bidder.

If the lowest bidder was not selected, please have the appropriate personnel sign the certification on page 2.

Mayor's Signature* Date _____

Business Administrator/Manager Signature Date _____

*For direct appointments of the Governing Body, Council President or at the discretion of the Director, the most senior member of the Governing Body may sign the waiver in lieu of the Mayor.

The Financial Officer affirms that there is adequate funding available for this action.

Financial Officer Signature

I certify that the vendor selected is in compliance with the adopted Pay to Play Ordinance and that the vendor was notified of any restrictions with respect to campaign contributions.

Certifying Officer Date _____

For LGS use only:

Approved Denied

Director or Designee, Date _____
Division of Local Government Services

Number Assigned _____

R-14

SE:dh
03-12-24

**RESOLUTION AUTHORIZING THE CITY TO RECEIVE PROPOSALS FOR
OPERATION AND MANAGEMENT OR ADMINISTRATION
OF SOCIAL SERVICE FACILITIES OR PROGRAMS**

WHEREAS, the City of Camden has a need for the operation and management or administration of Social Service Facilities or Programs; and

WHEREAS, the City of Camden desires to initiate the competitive contracting process to solicit proposals for the Operation and Management or Administration of Social Service Facilities or Programs; and

WHEREAS, pursuant to N.J.S.A. 40A:11-4.3, in order to initiate the competitive contracting process, Council of the City of Camden must pass a resolution authorizing the use of the competitive contracting; and

WHEREAS, pursuant to N.J.S.A. 40A:11-4.1b(2), the Department of Community Affairs Division of Local Government Services must approve the City's use of the competitive contracting process to solicit proposals for the Operation and Management or Administration of Social Service Facilities or Programs; now therefore

BE IT RESOLVED, by the Council of the City of Camden that the City is hereby authorized to initiate the competitive contracting process to solicit proposals for the Operation and Management or Administration of Social Service Facilities or Programs.

BE IT FURTHER RESOLVED, that pursuant to N.J.S.A. 52:27BBB-23, a true copy of this Resolution shall be forwarded to the State Commissioner of Community Affairs, who shall have ten (10) days from the receipt thereof to veto this Resolution. All notices of veto shall be filed in the Office of the Municipal Clerk.

Date: March 12, 2024

The above has been reviewed
and approved as to form.



DANIEL S. BLACKBURN
City Attorney

ANGEL FUENTES
President, City Council

ATTEST: _____
LUIS PASTORIZA
Municipal Clerk



CITY OF CAMDEN — CITY COUNCIL ACTION REQUEST FORM

COUNCIL MEETING DATE: 03/12/2024

TO: City Council
FROM: Timothy J. Cunningham, Business Administrator

TITLE OF ORDINANCE/RESOLUTION: RESOLUTION AUTHORIZING THE CITY OF CAMDEN TO UTILIZE THE COMPETITIVE CONTRACTING PROCESS TO RECEIVE PROPOSALS FOR THE OPERATION AND MANAGEMENT OR ADMINISTRATION OF SOCIAL SERVICE FACILITIES OR PROGRAMS

Point of Contact:	Lateefah Chandler	Admin-Purchasing	856-757-7475	lachandl@ci.camden.nj.us
	Name	Department-Division-Bureau	Phone	Email

ENDORSEMENTS

	Recommend Approval (Y/N)	Signature	Date	Comments
Responsible Department Director				
Supporting Department Director (if necessary)				
Grants Management				
Qualified Purchasing Agent	Y			
Director of Finance				
Approved by: Business Administrator			2/22	

Attachments (list and attach all available):

1. Waiver Request Form Attached for State DCA/DLGS Approval - (If applicable)¹
2. Certification of Funds²
3. Addition supporting documents.

"Walk-on" note: All walk-on legislation must be pre-approved by the Business Administrator. The Department Director and Contact Person are jointly responsible for delivering all necessary documents to the City Clerk for distribution at the Council Meeting.

Received by:

City Attorney	Signature	Date
		FEB 29 2024

¹ For Example: Form "A" - Request for approval of Employees Requiring Advice and Consent of Governing Body, Form "D" - Contract Request, Form "E" - Creation/Extension of Services, Form "G" - Grant Approval, Form "H" - Bond Ordinance or Contract Request, Form "I", "Best Price Insurance Contracting" Model Ordinance

² Mandatory for any financial commitment to the City or expenditure of City Funds.

EXECUTIVE SUMMARY

TITLE OF ORDINANCE/RESOLUTION: RESOLUTION AUTHORIZING THE CITY OF CAMDEN TO UTILIZE THE COMPETITIVE CONTRACTING PROCESS TO RECEIVE PROPOSALS FOR THE OPERATION AND MANAGEMENT OR ADMINISTRATION OF SOCIAL SERVICE FACILITIES OR PROGRAMS

FACTS/BACKGROUND: (Executive level details. Short concise bullets)

- Per N.J.S.A 40A:11-4.3(a), governing body approval is required before utilizing the competitive contracting process for services enumerated in N.J.S.A 40A:11-4.1
- N.J.S.A 40A:11-4.1 (2) the operation, management or administration of social service facilities or programs is an approved specialized goods and services for which competitive contracting can be used.

AMOUNT OF PROPOSED CONTRACT or TOTAL COST OF PROPOSAL: N/A

APPROPRIATION NUMBER: N/A

PROCUREMENT: N/A

IMPACT STATEMENT:

- N/A

SUBJECT MATTER EXPERTS/ADVOCATES:

- N/A

COORDINATION:

- N/A

Prepared by: LATEEAH CHANDLER

856-757-7159

Name

Phone/Email

**STATE OF NEW JERSEY
DEPARTMENT OF COMMUNITY AFFAIRS
DIVISION OF LOCAL GOVERNMENT SERVICES
CONTRACT REQUEST FORM**

This form must be filled out in its entirety and is intended to provide the Division with appropriate information to determine whether to approve a new or extended service. Please provide any additional information you believe will help the Division make an informed decision.

Municipality	CITY OF CAMDEN
--------------	----------------

Professional Service or EUS Type	N/A
Name of Vendor	N/A
Purpose or Need for service:	COMPETITIVE CONTRACTING FOR THE OPERATION, MANAGEMENT OR ADMINISTRATION OF SOCIAL SERVICE FACILITIES
Contract Award Amount	N/A
Term of Contract	N/A
Temporary or Seasonal	N/A
Grant Funded (attach appropriate documentation allowing for service through grant funds)	N/A
Please explain the procurement process (i.e. bids, RFQ, competitive contracting, etc.)	NJSA 40A:11-4.1 ET SEQ
Were other proposals received? If so, please attach the names and amounts for each proposal received?	N/A

Please attach the RFP, evaluation memoranda or evaluation forms used to evaluate the vendors and a list of all bidders and the bid amounts associated with each bidder.

If the lowest bidder was not selected, please have the appropriate personnel sign the certification on page 2.

Mayor's Signature* Date _____

Business Administrator/Manager Signature Date _____

*For direct appointments of the Governing Body, Council President or at the discretion of the Director, the most senior member of the Governing Body may sign the waiver in lieu of the Mayor.

The Financial Officer affirms that there is adequate funding available for this action.

Financial Officer Signature

I certify that the vendor selected is in compliance with the adopted Pay to Play Ordinance and that the vendor was notified of any restrictions with respect to campaign contributions.

Certifying Officer Date _____

For LGS use only:

 Approved Denied

Director or Designee, Date _____
Division of Local Government Services

Number Assigned _____

R-15

SE:dh
03-12-24

**RESOLUTION AUTHORIZING THE CITY TO RECEIVE PROPOSALS FOR
CONSULTING SERVICES AND OVERSIGHT
OF THE EMERGENCY SOLUTIONS GRANT PROGRAM**

WHEREAS, the City of Camden has received an Emergency Solutions Grant from HUD, which provides emergency assistance to people who are experiencing a housing crisis and/or homelessness; and

WHEREAS, the City of Camden desires to initiate the competitive contracting process to solicit proposals for Consulting Services and Oversight of the Emergency Solutions Grant Program; and

WHEREAS, pursuant to N.J.S.A. 40A:11-4.3, in order to initiate the competitive contracting process, Council of the City of Camden must pass a resolution authorizing the use of the competitive contracting; and

WHEREAS, pursuant to N.J.S.A. 40A:11-4.1m, the Department of Community Affairs Division of Local Government Services must approve the City's use of the competitive contracting process to solicit proposals for Consulting Services; now therefore

BE IT RESOLVED, by the Council of the City of Camden that the City is hereby authorized to initiate the competitive contracting process to solicit proposals for Consulting Services and Oversight of the Emergency Solutions Grant Program.

BE IT FURTHER RESOLVED, that pursuant to N.J.S.A. 52:27BBB-23, a true copy of this Resolution shall be forwarded to the State Commissioner of Community Affairs, who shall have ten (10) days from the receipt thereof to veto this Resolution. All notices of veto shall be filed in the Office of the Municipal Clerk.

Date: March 12, 2024

The above has been reviewed
and approved as to form.



DANIEL S. BLACKBURN
City Attorney

ANGEL FUENTES
President, City Council

ATTEST: _____
LUIS PASTORIZA
Municipal Clerk



CITY OF CAMDEN — CITY COUNCIL ACTION REQUEST FORM

COUNCIL MEETING DATE: 03/12/2024

TO: City Council
FROM: Timothy J. Cunningham, Business Administrator

TITLE OF ORDINANCE/RESOLUTION: RESOLUTION AUTHORIZING THE CITY OF CAMDEN TO UTILIZE THE COMPETITIVE CONTRACTING PROCESS TO RECEIVE PROPOSALS FOR CONSULTING SERVICES AND OVERSIGHT OF THE EMERGENCY SOLUTIONS GRANT PROGRAM

Point of Contact: Lateefah Admin-Purchasing 856-757-7475 lachandl@ci.camden.nj.us
Chandler

Name	Department- Division- Bureau	Phone	Email
------	------------------------------------	-------	-------

ENDORSEMENTS

Recommend Approval (Y/N)	Signature	Date	Comments
--------------------------	-----------	------	----------

Responsible
Department Director
Supporting Department
Director (if necessary)
Grants Management

Qualified Purchasing
Agent
Director of Finance

Y *Lateefah Chandler 2/21/2024*

Approved by:
Business Administrator

Signature

2/21

Date

Attachments (list and attach all available):

1. Waiver Request Form Attached for State DCA/DLGS Approval - (If applicable)¹
2. Certification of Funds²
3. Addition supporting documents.

"Walk-on" note: All walk-on legislation must be pre-approved by the Business Administrator. The Department Director and Contact Person are jointly responsible for delivering all necessary documents to the City Clerk for distribution at the Council Meeting.

Received by:
City Attorney

Signature

FEB 29 2024

Date

¹ For Example: Form "A" - Request for approval of Employees Requiring Advice and Consent of Governing Body, Form "D" - Contract Request, Form "E" - Creation/Extension of Services, Form "G" - Grant Approval, Form "H" - Bond Ordinance or Contract Request, Form "I", "Best Price Insurance Contracting" Model Ordinance

² Mandatory for any financial commitment to the City or expenditure of City Funds.

EXECUTIVE SUMMARY

TITLE OF ORDINANCE/RESOLUTION: RESOLUTION AUTHORIZING THE CITY OF CAMDEN TO UTILIZE THE COMPETITIVE CONTRACTING PROCESS TO RECEIVE PROPOSALS FOR CONSULTING SERVICES AND OVERSIGHT OF THE EMERGENCY SOLUTIONS GRANT PROGRAM

FACTS/BACKGROUND: (Executive level details. Short concise bullets)

- Per N.J.S.A 40A:11-4.3(a), governing body approval is required before utilizing the competitive contracting process for services enumerated in N.J.S.A 40A:11-4.1
- N.J.S.A 40A:11-4.1 (m) Consulting Services is an approved specialized goods and services for which competitive contracting can be used.

AMOUNT OF PROPOSED CONTRACT or TOTAL COST OF PROPOSAL: N/A

APPROPRIATION NUMBER: N/A

PROCUREMENT: N/A

IMPACT STATEMENT:

- N/A

SUBJECT MATTER EXPERTS/ADVOCATES:

- N/A

COORDINATION:

- N/A

Prepared by: LATEEAH CHANDLER

856-757-7159

Name

Phone/Email

**STATE OF NEW JERSEY
DEPARTMENT OF COMMUNITY AFFAIRS
DIVISION OF LOCAL GOVERNMENT SERVICES
CONTRACT REQUEST FORM**

This form must be filled out in its entirety and is intended to provide the Division with appropriate information to determine whether to approve a new or extended service. Please provide any additional information you believe will help the Division make an informed decision.

Municipality	CITY OF CAMDEN
Professional Service or EUS Type	N/A
Name of Vendor	N/A
Purpose or Need for service:	COMPETITIVE CONTRACTING FOR THE OPERATION, MANAGEMENT OR ADMINISTRATION OF SOCIAL SERVICE FACILITIES
Contract Award Amount	N/A
Term of Contract	N/A
Temporary or Seasonal	N/A
Grant Funded (attach appropriate documentation allowing for service through grant funds)	N/A
Please explain the procurement process (i.e. bids, RFQ, competitive contracting, etc.)	NJSA 40A:11-4.1 ET SEQ
Were other proposals received? If so, please attach the names and amounts for each proposal received?	N/A

Please attach the RFP, evaluation memoranda or evaluation forms used to evaluate the vendors and a list of all bidders and the bid amounts associated with each bidder.

If the lowest bidder was not selected, please have the appropriate personnel sign the certification on page 2.

Mayor's Signature* Date _____

Business Administrator/Manager Signature Date _____

*For direct appointments of the Governing Body, Council President or at the discretion of the Director, the most senior member of the Governing Body may sign the waiver in lieu of the Mayor.

The Financial Officer affirms that there is adequate funding available for this action.

Financial Officer Signature

I certify that the vendor selected is in compliance with the adopted Pay to Play Ordinance and that the vendor was notified of any restrictions with respect to campaign contributions.

 N/A _____ Date _____
Certifying Officer

For LGS use only:

Approved Denied

_____ Date _____
Director or Designee,
Division of Local Government Services

Number Assigned _____

R-16

SE:dh
03-12-24

RESOLUTION AUTHORIZING THE CITY TO RECEIVE PROPOSALS FOR GRANT WRITING SERVICES

WHEREAS, the City of Camden needs assistance in seeking external grant funding opportunities and writing competitive grant proposals; and

WHEREAS, the City of Camden desires to initiate the competitive contracting process to solicit proposals for Grant Writing Services; and

WHEREAS, pursuant to N.J.S.A. 40A:11-4.3, in order to initiate the competitive contracting process, Council of the City of Camden must pass a resolution authorizing the use of the competitive contracting; and

WHEREAS, pursuant to N.J.S.A. 40A:11-4.1q, the Department of Community Affairs Division of Local Government Services must approve the City's use of the competitive contracting process to solicit proposals for Grant Writing Services; now therefore

BE IT RESOLVED, by the Council of the City of Camden that the City is hereby authorized to initiate the competitive contracting process to solicit proposals for Grant Writing Services.

BE IT FURTHER RESOLVED, that pursuant to N.J.S.A. 52:27BBB-23, a true copy of this Resolution shall be forwarded to the State Commissioner of Community Affairs, who shall have ten (10) days from the receipt thereof to veto this Resolution. All notices of veto shall be filed in the Office of the Municipal Clerk.

Date: March 12, 2024

The above has been reviewed and approved as to form.

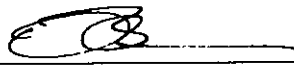

DANIEL S. BLACKBURN
City Attorney

ANGEL FUENTES
President, City Council

ATTEST: _____
LUIS PASTORIZA
Municipal Clerk



CITY OF CAMDEN — CITY COUNCIL ACTION REQUEST FORM

COUNCIL MEETING DATE: 03/12/2024

TO: City Council
FROM: Timothy J. Cunningham, Business Administrator

TITLE OF ORDINANCE/RESOLUTION: RESOLUTION AUTHORIZING THE CITY OF CAMDEN TO UTILIZE THE COMPETITIVE CONTRACTING PROCESS TO RECEIVE PROPOSALS FOR GRANT WRITING SERVICES

Point of Contact: Lateefah Chandler Admin-Purchasing 856-757-7475 lachandl@ci.camden.nj.us

Name Department-Division-Bureau Phone Email

ENDORSEMENTS

Recommend Approval (Y/N) Signature Date Comments

Responsible Department Director Supporting Department Director (if necessary) Grants Management

Qualified Purchasing Agent Director of Finance

Y Lateefah CA 2/6/2024

Approved by: Business Administrator

Signature Date

Attachments (list and attach all available):

- 1. Waiver Request Form Attached for State DCA/DLGS Approval - (If applicable)1
2. Certification of Funds2
3. Addition supporting documents.

Walk-on note: All walk-on legislation must be pre-approved by the Business Administrator. The Department Director and Contact Person are jointly responsible for delivering all necessary documents to the City Clerk for distribution at the Council Meeting.

Received by: City Attorney

Signature Date FEB 29 2024

1 For Example: Form "A" - Request for approval of Employees Requiring Advice and Consent of Governing Body, Form "D" - Contract Request, Form "E" - Creation/Extension of Services, Form "G" - Grant Approval, Form "H" - Bond Ordinance or Contract Request, Form "I", "Best Price Insurance Contracting" Model Ordinance

2 Mandatory for any financial commitment to the City or expenditure of City Funds.

EXECUTIVE SUMMARY

TITLE OF ORDINANCE/RESOLUTION: RESOLUTION AUTHORIZING THE CITY OF CAMDEN TO UTILIZE THE COMPETITIVE CONTRACTING PROCESS TO RECEIVE PROPOSALS FOR GRANT WRITING SERVICES

FACTS/BACKGROUND: (Executive level details. Short concise bullets)

- Per N.J.S.A 40A:11-4.3(a), governing body approval is required before utilizing the competitive contracting process for services enumerated in N.J.S.A 40A:11-4.1
- N.J.S.A 40A:11-4.1 (q) Grant writing services is an approved specialized goods and services for which competitive contracting can be used.

AMOUNT OF PROPOSED CONTRACT or TOTAL COST OF PROPOSAL: N/A

APPROPRIATION NUMBER: N/A

PROCUREMENT: N/A

IMPACT STATEMENT:

- N/A

SUBJECT MATTER EXPERTS/ADVOCATES:

- N/A

COORDINATION:

- N/A

Prepared by: LATEEAH CHANDLER

856-757-7159

Name

Phone/Email

**STATE OF NEW JERSEY
DEPARTMENT OF COMMUNITY AFFAIRS
DIVISION OF LOCAL GOVERNMENT SERVICES
CONTRACT REQUEST FORM**

This form must be filled out in its entirety and is intended to provide the Division with appropriate information to determine whether to approve a new or extended service. Please provide any additional information you believe will help the Division make an informed decision.

Municipality	CITY OF CAMDEN
--------------	----------------

Professional Service or EUS Type	N/A
Name of Vendor	N/A
Purpose or Need for service:	COMPETITIVE CONTRACTING FOR GRANT WRITING SERVICES
Contract Award Amount	N/A
Term of Contract	N/A
Temporary or Seasonal	N/A
Grant Funded (attach appropriate documentation allowing for service through grant funds)	N/A
Please explain the procurement process (i.e. bids, RFQ, competitive contracting, etc.)	NJSA 40A:11-4.1 ET SEQ
Were other proposals received? If so, please attach the names and amounts for each proposal received?	N/A

Please attach the RFP, evaluation memoranda or evaluation forms used to evaluate the vendors and a list of all bidders and the bid amounts associated with each bidder.

If the lowest bidder was not selected, please have the appropriate personnel sign the certification on page 2.

Mayor's Signature

Date _____

Business Administrator/Manager Signature

Date _____

DB:dh
03-12-24

R-17

**RESOLUTION AUTHORIZING RENTING VEHICLES FROM HERTZ CORPORATION
VIA NJ STATE COOPERATIVE**

WHEREAS, under N.J.S.A. 40A: 11-12, a municipality may, without advertising for bids, purchase materials, supplies or equipment under a contract entered into on behalf of the State by the Division of Purchase and Property in the Department of Treasury, State of New Jersey; and

WHEREAS, it has been certified by the Purchasing Agent of the City of Camden that the City seeks to rent eleven (11) passenger vehicles and four (4) 15 passenger vans under State Contract #18-FLEET-00234 for the need to transport safe & secure employees and inspectors to perform their daily duties in the City of Camden; and

WHEREAS, the municipality seeks to purchase this equipment under said State contract from The Hertz Corporation for an amount not to exceed ONE HUNDRED FIFTY THOUSAND DOLLARS (\$150,000.00); and

WHEREAS, there will be substantial savings by the municipality by purchasing under the State Contract and this procedure is in the best interest of the City of Camden; and

WHEREAS, pursuant to the directive of the Division of Local Government Services, a certification has been attached hereto which certifies that the funds for this expenditure are available and appropriated under the budget of the City of Camden under line items "G-02-FF-712-20P & 4-01-E4-600-917", and said certification has been signed by the Chief Financial Officer and approved as to form by the City Attorney; now, therefore

BE IT RESOLVED, by the City Council of the City of Camden, that the City of Camden is hereby authorized to award a contract to The Hertz Corporation, to purchase eleven (11) passenger vehicles and four (4) 15 passenger vans under State Contract #18-FLEET-00234 for usage in the City of Camden to transport safe & secure employees and inspectors to perform their daily duties for an amount not to exceed ONE HUNDRED FIFTY THOUSAND DOLLARS (\$150,000.00).

BE IT FURTHER RESOLVED, that pursuant to N.J.S.A. 52:27BBB-23, a true copy of this Resolution shall be forwarded to the State Commissioner of Community Affairs, who shall have ten (10) days from the receipt thereof to veto this Resolution. All notices of veto shall be filed in the Office of the Municipal Clerk.

Date: March 12, 2024

The above has been reviewed
and approved as to form.



DANIEL S. BLACKBURN
City Attorney

ANGEL FUENTES
President, City Council

ATTEST:

LUIS PASTORIZA
Municipal Clerk

CITY OF CAMDEN

CERTIFICATION AS TO THE AVAILABILITY OF FUNDS

I CERTIFY, DIRECTOR FOR THE FINANCE DEPARTMENT FOR THE CITY OF CAMDEN, THAT WITH RESPECT TO THE AWARD OF A CONTRACT OR EXPENDITURE OF FUNDS TO: HERTZ CORPORATION

THAT THE FUNDS ARE AVAILABLE AS OF THE DATE OF THIS RESOLUTION/CERTIFICATION, FROM ONE OF THE FOLLOWING:

- BUDGET APPROPRIATION:G-02-FF-712-20P (\$100,000.00) 4-01-E4-600-917 (\$50,000.00)

AMOUNT: \$ 150,000.00

- DEDICATED BY RIDER:

AMOUNT:\$

- TEMPORARY RESERVE FOR STATE AND FEDERAL GRANT:

AMOUNT:\$

- CAPITAL ORDINANCE

AMOUNT:\$

- TRUST ACCOUNT:

AMOUNT: \$

DETERMINATION OF VALUE CERTIFICATION

I CERTIFY, AS CHIEF FINANCIAL OFFICER, THAT THE ANTICIPATED VALUE OF THE CONTRACT, OVER THE FULL LIFE, WILL BE: \$ 150,000.00

DESCRIPTION OF THE GOODS AND SERVICES TO BE PROCURED: RESOLUTION AUTHORIZING RENTING VEHICLES FROM HERTZ CORPORATION VIA NJ STATE COOPERATIVE .

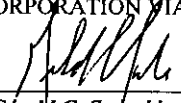

Gerald C. Seneski
Director of Finance
Date: 2/21



CITY OF CAMDEN — CITY COUNCIL ACTION REQUEST FORM

COUNCIL MEETING DATE: 03/12/2024

TO: City Council
FROM: Timothy J. Cunningham, Business Administrator

TITLE OF ORDINANCE/RESOLUTION: RESOLUTION AUTHORIZING RENTING VEHICLES FROM HERTZ CORPORATION VIA NJ STATE COOPERATIVE

Point of Contact:	Lateefah Chandler	Admin-Purchasing	856-757-7475	lachandl@ci.camden.nj.us
	Name	Department-Division-Bureau	Phone	Email

ENDORSEMENTS

	Recommend Approval (Y/N)	Signature	Date	Comments
Responsible Department Director	Y			
Supporting Department Director (if necessary)				
Director of Grants Management				
Qualified Purchasing Agent	Y	<i>Lateefah Chandler</i>	2/21/2024	
Director of Finance	Y	<i>[Signature]</i>	2/21	
Approved by: Business Administrator		<i>[Signature]</i>	2/22	

Attachments (list and attach all available):

1. Waiver Request Form Attached for State DCA/DLGS Approval - (if applicable)¹
2. Certification of Funds²
3. Addition supporting documents.

"Walk-on" note: All walk-on legislation must be pre-approved by the Business Administrator. The Department Director and Contact Person are jointly responsible for delivering all necessary documents to the City Clerk for distribution at the Council Meeting.

Received by: *[Signature]* Date: FEB 29 2024

City Attorney Signature Date

¹ For Example: Form "A" - Request for approval of Employees Requiring Advice and Consent of Governing Body, Form "D" - Contract Request, Form "E" - Creation/Extension of Services, Form "G" - Grant Approval, Form "H" - Bond Ordinance or Contract Request, Form "I", "Best Price Insurance Contracting" Model Ordinance

² Mandatory for any financial commitment to the City or expenditure of City Funds.

CAMDEN CITY
 520 MARKET STREET
 P. O BOX 95120
 CAMDEN, NJ 08101-5120
 TEL (856)757-7000

REQUISITION	
NO.	R2400236

SHIP TO	DEPT OF PUBLIC WORKS 101 NEWTON AVENUE CAMDEN, NJ 08103 CHERYL PINE	CITY OF CAMDEN FINANCE DEPARTMENT 2024 JAN 23 PM 1:18
	VENDOR # : HER30 THE HERTZ CORPORATION P.O. BOX 121124 DALLAS, TX 75312	

ORDER DATE: 01/19/24
 DELIVERY DATE: 01/19/24
 STATE CONTRACT: 18-FLEET-00234
 F.O.B. TERMS:

QTY/UNIT	DESCRIPTION	ACCOUNT NO.	UNIT PRICE	TOTAL COST
6.00 MO	RENTAL OF 4 15 PASSENGER VANS FOR PUBLIC WORKS IN ORDER TO TRANSPORT TEMPORARY EMPLOYEES TO JOB ASSIGNMENTS LOCATIONS THROUGHOUT THE DAY FOR SAFE & SECURE PROGRAM (TEMPORARY EMPLOYEES)	G-02-FF-712-20P	7,900.0000	47,400.00
4.00 EA	RENEWAL FEES (DOMESTIC FEES FOR A PERIOD OF 6 MONTHS)	4-01-E6-700-917	140.0000	560.00
COST PER MONTH \$1,975 X 4VANS X 6MTH = 47,400.00 + RENEWAL FEES \$140.00 X 4 = \$ 47,960.00 ACCOUNT #: 0001012320 APPLICANT: 44083390				
			TOTAL	47,960.00

GRANTS BUREAU

2024 JAN 19 AM 10:32

2024 JAN 23 PM 2:54

CITY OF CAMDEN PURCHASING BUREAU

[Handwritten Signature]
 1/23/24

Approved:

[Handwritten Signature]
 Keith Walker 1/19/24
 Department Head Date

I hereby certify that the work or supplies specified are necessary for the proper transaction of the business of this bureau or office

[Handwritten Signature]
 Receiver of Goods 1/19/24
 Date

FORWARD THIS COPY OF THE REQUISITION TO THE PURCHASING BUREAU

EXECUTIVE SUMMARY

TITLE OF ORDINANCE/RESOLUTION: RESOLUTION AUTHORIZING RENTING VEHICLES FROM HERTZ CORPORATION VIA NJ STATE COOPERATIVE

FACTS/BACKGROUND: (Executive level details. Short concise bullets)

- The City rents 11 passenger vehicles and 4 15 passenger vans from The Hertz Corporation, PO Box 121124, Dallas TX 75312.
- We are finalizing the installation of the charging station for 11 Chevy Bolt vehicles and will discontinue the rental of the passenger vehicles by June 2024 - \$660.00 per vehicle plus taxes
- Safe & Secure Grant expires December 31, 2024 and the rental of the 4 passenger vans will discontinue at this time - \$1950.00 per van plus taxes

AMOUNT OF PROPOSED CONTRACT or TOTAL COST OF PROPOSAL: \$150,000.00

APPROPRIATION NUMBER: G-02-FF-712-20P (\$100,000.00) & 4-01-E4-600-917 (\$50,000.00)

PROCUREMENT: N.J.S.A. 40A:11-12 - NJSC #18-FLEET-00234

IMPACT STATEMENT:

- Vehicles needed to transport Safe & Secure employees and inspectors to perform their daily duties

SUBJECT MATTER EXPERTS/ADVOCATES:

- N/A

COORDINATION:

- N/A

Prepared by: LATEEAH CHANDLER

856-757-7475

Name

Phone/Email

**STATE OF NEW JERSEY
DEPARTMENT OF COMMUNITY AFFAIRS
DIVISION OF LOCAL GOVERNMENT SERVICES
CONTRACT REQUEST FORM**

This form must be filled out in its entirety and is intended to provide the Division with appropriate information to determine whether to approve a new or extended service. Please provide any additional information you believe will help the Division make an informed decision.

Municipality	CITY OF CAMDEN
Professional Service or EUS Type	N/A
Name of Vendor	HERTZ CORPORATION
Purpose or Need for service:	RENTAL OF 11 PASSENGER VEHICLES & 4 15 PASSENGER VANS
Contract Award Amount	\$208,825.54
Term of Contract	10 MONTHS
Temporary or Seasonal	N/A
Grant Funded (attach appropriate documentation allowing for service through grant funds)	NO
Please explain the procurement process (i.e. bids, RFQ, competitive contracting, etc.)	NJSA 40A:11-12
Were other proposals received? If so, please attach the names and amounts for each proposal received?	N/A

Please attach the RFP, evaluation memoranda or evaluation forms used to evaluate the vendors and a list of all bidders and the bid amounts associated with each bidder.

If the lowest bidder was not selected, please have the appropriate personnel sign the certification on page 2.

	Date _____
Mayor's Signature*	
	Date _____
Business Administrator/Manager Signature	

*For direct appointments of the Governing Body, Council President or at the discretion of the Director, the most senior member of the Governing Body may sign the waiver in lieu of the Mayor.

The Financial Officer affirms that there is adequate funding available for this action.

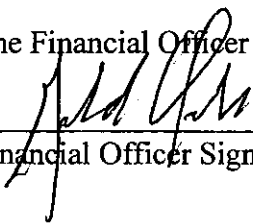

Financial Officer Signature

I certify that the vendor selected is in compliance with the adopted Pay to Play Ordinance and that the vendor was notified of any restrictions with respect to campaign contributions.

N/A NISSC

Certifying Officer

Date _____

For LGS use only:

Approved

Denied

Date

Director or Designee,
Division of Local Government Services

Number Assigned _____

Range of Accounts: G-02-FF-712-20P to G-02-FF-712-20P Include Cap Accounts: Yes As Of: 01/23/24

Current Period: 01/19/24 to 01/23/24

Audit Report Type: Standard

Note: Transaction Beginning Balance includes all Adds/Changes occurring on or prior to the As of Date

Note: Requisitions charged to Existing Blanket PO's are not included in Requested YTD.

* Transaction is included in Previous and/or Begin Balance ** Transaction is not included in Balance

En = PO Line Item First Encumbrance Date BC = Blanket Control BS = Blanket Sub

Account No	Description	Adopted	Amended	Transfers	Modified	Balance YTD	%Used	Trans Amount	Trans Balance	User
Date	Transaction Data/Comment	Expended YTD	Encumber YTD	Reimbrsd YTD	Canceled	Unexpended				
		Expended Curr	Requested YTD	Reimbrsd Curr	Pd/Chrgd YTD					
G-02-FF-712-20P	HC22:8445 - Clean & Safe	0.00	0.00	3,680,000.00	3,680,000.00	1,956,255.58	46			
		1,646,842.92	29,501.50	0.00	0.00	2,033,157.08				
		49,556.40	47,400.00	0.00	1,676,344.42					
	Begin Balance: 01/19/24							49,556.40-	2,053,211.98	
	01/19/24 Expenditure PR240119							47,400.00-	2,003,655.58	NHW
	01/19/24 RQ R2400236 1 RENTAL OF 4 15 PASSENGER VANS Open			Reference 11/700 48					1,956,255.58	LEC
				HER30 THE HERTZ CORPORATION						
Control: NOC	Total	0.00	0.00	3,680,000.00	3,680,000.00	1,956,255.58	46			
		1,646,842.92	29,501.50	0.00	0.00	2,033,157.08				
		49,556.40	47,400.00	0.00	1,676,344.42					
Department: 712	Total	0.00	0.00	3,680,000.00	3,680,000.00	1,956,255.58	46			
		1,646,842.92	29,501.50	0.00	0.00	2,033,157.08				
		49,556.40	47,400.00	0.00	1,676,344.42					
CAFR: FF	US Department of Treasury Total	0.00	0.00	3,680,000.00	3,680,000.00	1,956,255.58	46			
		1,646,842.92	29,501.50	0.00	0.00	2,033,157.08				
		49,556.40	47,400.00	0.00	1,676,344.42					

Initial Report _____ Revised Report x Closing Report _____
 Bureau of Grants Management Grant Summary Form
 Grant Status Code: G
 (green - g; yellow - y; red - r)

Department: Public Works

Grant Administrator: CherylPine/Keith Walker

Grant Administrator #: (856) 757-7139

Project Name:		Clean and Safe Parks Commercial Corridors Program			
Grant/Funding Agency Program:		Coronavirus Local Fiscal Recovery Fund			
Grant Federal CFDA or State GIMS Number:					
City Contract Date:		City Contract #:			
Application Resolution #:		Appropriation Code :		G-02-41-765-102; G-02-FF-712-20P	
Funding Source:		ARP			
Pass Through: circle one	Y or <input checked="" type="radio"/> N	Source:	ARP		
Amount of Grant:		1,044,000.			
Local Match: circle one	Y or <input checked="" type="radio"/> N	Cash:		In-Kind:	
Budget Insertion Resolution # & Date:		Accepting Grant Resolution # MC:			
Term of Grant:		3/21 – 12/24		Location of Activity:	
Date of Analysis:		1.23.2024		Reviewed By: Kelly Mobley	

Summary:

23-Jan-24: The Department of Public Works is processing requisition #R2400236 for Hertz Corporation for the purpose of renting 4 vans for 6 months at a rate of \$1,975 each per month. Also includes renewal fees totaling \$140.00

21-Dec-23 The Department of Public Works is processing purchase order #23-041171 for Hertz Corporation Rental Agreement #998884530 (\$1,372.00), 998884526 (\$1,858.06), 998939616 (\$2,113.90), 998681025 (\$1,954.36), 998939620 (\$1,973.90); 998679614 (1954.36); 998940552 (\$1,973.90)–Total payable: \$13,200.48

20-Dec-23 The Department of Public Works is processing purchase order #23-041171 for Hertz Corporation Rental Agreement #998681036 (\$1,954.36), 998940563 (\$1,973.90), 998679625 (\$1,954.36), 99893631(\$1,973.90) –Total payable: \$7,856.52

14-Nov-23 The Department of Public Works is processing purchase order #23-02140 for Hertz Corporation Rental Agreement #998640090 (\$1,914.06), 998640101 (\$382.81), 998679592 (\$2,223.84), 998640624(\$1,914.06), 998640635 (\$382.81) and 998681003 (\$2,223.84). Total invoice: \$8,702.46 This writer does not have access to the capital account. According to the department, \$280.00 should be charged to 3-01-E6-700-999 and the balance should be charged to G-02-FF-712-20P. Once payment is processed, this PO should be closed out. Department is requesting partial payments for invoices: 99681003 and 998679592

25-Oct-23: Based on the request of the Purchasing Agent and the need for the City to change where the uniforms would be charged to for the Clean and Safe Parks Program (understanding that these uniforms are for these employees only) authorization is being grant to charge the entire amount of the to the grant.

Initial Report _____ Revised Report x Closing Report _____
Bureau of Grants Management Grant Summary Form
Grant Status Code: G
(green - g; yellow - y; red - r)

11-Oct-23: The Department of Public Works is processing requisition #23-02948 for Smart Stitch LLC (uniforms) \$966.00 G-02-41-765-102. The balance of the request will be utilized from the departmental code 3-01-E6-702-915.

23-Aug-23: The Department of Public Works is processing purchase order #23-02140 for Hertz Corporation Rental Agreement Invoice #998884515 and 998892425 in the amount of \$1,914.06 each or \$3,828.12

15-Aug-23: The Department of Public Works is processing purchase order #23-00319 for Hertz Corporation Rental Agreement #998640591, 998640075, 998884493, 998892403, 998640602, 998640086, 998884504, 998892414 and 998640613 in the amount of \$1,914.06 each.

15-Aug-23: The Department of Public Works is processing purchase order #23-00319 for Hertz Corporation Rental Agreement #998640064, 998884482, and 998892392 in the amount of \$1,914.06 each. Total Payment against this purchase order: \$5,742.18

5-May-23: The Department of Public Works is processing purchase order #23-00319 for Hertz Corporation Rental Agreement #9988923181, 998884471, 998640053, and 998640580 in the amount of \$1,914.06 each. Total Payment against this purchase order: \$7,656.24

14-Apr-23: The Department of Public Works is processing two requisitions for Smart Stitch LLC to purchase uniforms and one requisition to HOME Depot to purchase supplies. These costs are associated with the Clean and Safe Commercial Corridors program. (Uniforms for employees and supplies for work to be performed) A budget adjustment may be necessary soon for uniforms and supplies as the funds allocated for both categories is dwindling.

4-Apr-23: The Department of Public Works is processing purchase order #23-00319 for Hertz Corporation Rental Agreement #998884456 in the amount of \$1,914.05 and Rental Agreement #998640042 in the amount of \$1,914.06. Total Payment against this purchase order: \$3,828.12

17-Mar-23: The Department of Public Works is processing purchase order #23-00319 for Hertz Corporation Rental Agreement #998884460 and #998892370: Total Amount \$3,828.12.

16-Mar-23: The Department of Public Works is processing purchase order #C2204433 for purpose of paying costs associated with supplies from HOME Depot in the amount of \$363.70 (portion with ARP Funding). It is this writer's expressed recommendation that the department amend their budget to include supplies for the work that will be performed with use of ARP Funds. As you will note - while equipment is mentioned as a cost category, there is no mention of supplies.

3-Mar-23: The Department of Public Works is processing purchase order #C2204063 for purpose of paying costs associated with the use of four (4) vans for the period 10/21/22 - 11/19/22 (cost: \$7,656.24); and the use of two (2) vans for the period 12/9/22 - 1/7/23 (cost: \$3,828.12) and one (1) van for the period 9/21/22 - 10/20/22 (cost: \$2,110.06). Total Costs: \$13,594.42

16-Feb-23: The Department of Public Works is processing purchase order #C2204053 for purpose of paying costs associated with the use of four (4) vans for the period 9/10/22 - 12/08/22. Total Costs: \$13,594.42

1-Feb-23: The Department of Public Works is processing Purchase Requisitions #C23-00189 \$23,528.72 for the purpose of renting four (4) vans for a period of three (3) months. Vans are needed to transport temporary employees safely to city sites in order to perform daily job assignments. January 2023 - March 2023 Total amount requested: \$23,528.72 (\$90,000 allocated for vehicles.

14-Sep-22: The Department of Public Works is processing Purchase Requisitions #C2201203 \$19,300.00 and C2201531 \$13,680.00 for the purpose of renting four - 16 passenger vans during the months of September 2022 - December of 2022 to transport 60 temporary employees safely to City Sites throughout the City to perform daily job assignments. Total amount requested: \$32,980.00.

According to the quote from Hertz (no other quotes available) rentals are \$1,900 per month. The department is requesting the use of 4 vans versus the 2 vans approved in the budget. The budget and program should be updated to reflect this change. Further, the available ARP funds for this program is for 1 (one) year. ARP funding for this program is not available for a second year.

Initial Report _____ Revised Report x Closing Report _____
Bureau of Grants Management Grant Summary Form
Grant Status Code: G
(green - g; yellow - y; red - r)

Budget FY 22: \$913,561 (60 employees)
 \$90,000 (4 vehicles)
 \$40,439 (uniforms/equipment)
Total budget: \$1,044,000

Time Lines: 6 month employment intervals for various assignments

Problematic Areas/Recommendations: the project description and budget should be amended

ARP Clean and Safe Parks/Commercial Corridors Program



- Home
- My Account
- Advanced Search
- Supplier Registration
- Sign In
- Public Notice View
- Facility Code - Maint.
- Confid Police Co.
- RFCNCS
- Gov Connection
- Governmental Purc
- NJ SRC
- NJSTART State Cont.
- LOCAL FINANCE N...
- W3 Mason - Logi...
- New Chrome available
- All Bookmarks

Advanced Search

Results

Contract / Blanket #	Bid #	Description	Vendor	Type Code	Dollars Spent to Date	Organization	Status	Begin Date	End Date
20-GNSV2-00983		M0064 - Nationwide Vehicle Rental Services	The Hertz Corporation	NATCOOP/NJCOO P	\$145,620.44	Division of Purchase and Property	3PS - Sent	10/19/2019	05/20/2024

Exit

Type here to search

Taskbar area with system tray icons including clock (7:48 PM), date (11/19/2024), and various application icons.

R-18

DB:dh
03-12-24

**RESOLUTION AUTHORIZING A CONTRACT WITH MM SJ VENDING LLC TO
PROVIDE VENDING MACHINE SERVICES FOR VARIOUS CITY PROPERTIES**

WHEREAS, the MM SJ Vending LLC desires to provide vending machine service for various City of Camden properties; and

WHEREAS, the City of Camden desires to enter into an Agreement with MM SJ Vending LLC to provide these services as outlined in the agreement; now therefore

BE IT RESOLVED, by the City Council of the City of Camden, that the proper officers be and are hereby authorized to enter into an Agreement with the MM SJ Vending LLC to provide vending machine service for various City of Camden properties.

BE IT FURTHER RESOLVED, that pursuant to N.J.S.A. 52:27BBB-23, a true copy of this Resolution shall be forwarded to the State Commissioner of Community Affairs, who shall have ten (10) days from the receipt thereof to veto this Resolution. All notices of veto shall be filed in the Office of the Municipal Clerk.

Date: March 12, 2024

The above has been reviewed and approved as to form.



DANIEL S. BLACKBURN
City Attorney

ANGEL FUENTES
President, City Council

ATTEST: _____
LUIS PASTORIZA
Municipal Clerk



CITY OF CAMDEN — CITY COUNCIL ACTION REQUEST FORM

COUNCIL MEETING DATE: 03/12/2024

TO: City Council
FROM: Timothy J. Cunningham, Business Administrator

TITLE OF ORDINANCE/RESOLUTION: RESOLUTION AUTHORIZING A CONTRACT MM SJ VENDING LLC TO PROVIDE VENDING MACHINE SERVICES FOR VARIOUS CITY PROPERTIES

Point of Contact:	Lateefah Chandler	Admin-Purchasing	856-757-7475	lachandl@ci.camden.nj.us
	Name	Department-Division-Bureau	Phone	Email

ENDORSEMENTS

	Recommend Approval (Y/N)	Signature	Date	Comments
Responsible	Y			
Department Director				
Supporting Department Director (if necessary)				
Director of Grants Management				
Qualified Purchasing Agent	Y			
Director of Finance	Y			

Approved by:
Business Administrator

Signature

2/22
Date

Attachments (list and attach all available):

1. Waiver Request Form Attached for State DCA/DLGS Approval - (If applicable)¹
2. Certification of Funds²
3. Addition supporting documents.

"Walk-on" note: All walk-on legislation must be pre-approved by the Business Administrator. The Department Director and Contact Person are jointly responsible for delivering all necessary documents to the City Clerk for distribution at the Council Meeting.

FEB 29 2024

Received by:
City Attorney

Signature

Date

¹ For Example: Form "A" - Request for approval of Employees Requiring Advice and Consent of Governing Body, Form "D" - Contract Request, Form "E" - Creation/Extension of Services, Form "G" - Grant Approval, Form "H" - Bond Ordinance or Contract Request, Form "I", "Best Price Insurance Contracting" Model Ordinance

² Mandatory for any financial commitment to the City or expenditure of City Funds.

EXECUTIVE SUMMARY

TITLE OF ORDINANCE/RESOLUTION: RESOLUTION AUTHORIZING A CONTRACT MM SJ VENDING LLC TO PROVIDE VENDING MACHINE SERVICES FOR VARIOUS CITY PROPERTIES

FACTS/BACKGROUND: (Executive level details. Short concise bullets)

- MM SJ Vending LLC, 612 Gravelly Hollow Road, Unit H, Medford, NJ 08055 will provide vending machine services for city properties – Municipal Court 4th Floor & DPW 101 Newton.
- The vending machines will provide a convenience to employees by saving time from having to leave the premises, round the clock availability and employee moral (pick me up)
- MM SJ Vending LLC provides vending machine services to CCMUA, thus vendor is already in this area. Previous vendor did not have other locations to make this service profitable.
- City will not receive a commission on this service. Thus, pricing will on items will not reflect any additional markups.

AMOUNT OF PROPOSED CONTRACT or TOTAL COST OF PROPOSAL: N/A

APPROPRIATION NUMBER: N/A

PROCUREMENT: N.J.A.C. 5:34-9.4(b)(4)

IMPACT STATEMENT:

- Vending machines can enhance employee satisfaction, production and convenience.

SUBJECT MATTER EXPERTS/ADVOCATES:

- N/A

COORDINATION:

- N/A

Prepared by: LATEEAH CHANDLER

856-757-7475

Name

Phone/Email

**STATE OF NEW JERSEY
DEPARTMENT OF COMMUNITY AFFAIRS
DIVISION OF LOCAL GOVERNMENT SERVICES
CONTRACT REQUEST FORM**

This form must be filled out in its entirety and is intended to provide the Division with appropriate information to determine whether to approve a new or extended service. Please provide any additional information you believe will help the Division make an informed decision.

Municipality	CITY OF CAMDEN
Professional Service or EUS Type	N/A
Name of Vendor	MM SJ VENDING
Purpose or Need for service:	PROVING VENDING MACHINE SERVICE
Contract Award Amount	N/A
Term of Contract	12 MONTHS
Temporary or Seasonal	N/A
Grant Funded (attach appropriate documentation allowing for service through grant funds)	NO
Please explain the procurement process (i.e. bids, RFQ, competitive contracting, etc.)	N.J.A.C. 5:34-9.4(b)(4)
Were other proposals received? If so, please attach the names and amounts for each proposal received?	NO

Please attach the RFP, evaluation memoranda or evaluation forms used to evaluate the vendors and a list of all bidders and the bid amounts associated with each bidder.

If the lowest bidder was not selected, please have the appropriate personnel sign the certification on page 2.

Mayor's Signature* Date _____

Business Administrator/Manager Signature Date _____

*For direct appointments of the Governing Body, Council President or at the discretion of the Director, the most senior member of the Governing Body may sign the waiver in lieu of the Mayor.

The Financial Officer affirms that there is adequate funding available for this action.

Financial Officer Signature

I certify that the vendor selected is in compliance with the adopted Pay to Play Ordinance and that the vendor was notified of any restrictions with respect to campaign contributions.

 N/A _____ Date _____
Certifying Officer

For LGS use only:

Approved Denied

_____ Date _____
Director or Designee,
Division of Local Government Services

Number Assigned _____

MM SJ VENDING, LLC
612 GRAVELLY HOLLOW RD
UNIT H
MEDFORD, NJ 08055
856-209-5959
info@sivend.com

February 2, 2024

CITY OF CAMDEN
ATTN: Lateefah Chandler
520 Market Street
Camden, NJ 08102

via email: lachandl@ci.camden.nj.us

Dear Ms. Chandler:

I hope this letter finds you well. I am writing to propose a service agreement for the installation, maintenance, and restocking of snack and soda vending machines at two locations for the City of Camden:

Location A:
Municipal Court
4th Floor
520 Market Street
Camden, NJ 09102

Location B:
Department of Public Works
101 Newton Ave
Camden, NJ 08103

Our company, MM SJ Vending, LLC specializes in providing high-quality vending solutions tailored to meet the needs of various businesses and organizations. We understand the importance of providing convenient and reliable vending services to employees, visitors, and customers.

Here are the key aspects of our proposal:

Vending Machine Installation:

We will install snack and soda vending machines with cashless payment options at Location A and Location B to be placed in current defined area for each location.

Product Selection:

Our vending machines will offer a diverse selection of snacks and beverages, including popular brands and customizable choices based on the preferences of your employees and customers.

Regular Maintenance:

Our team will conduct routine maintenance checks to ensure that the vending machines are operating smoothly at all times. This includes cleaning and inspecting the machines for any technical issues.

Restocking Services:

We will regularly restock the vending machines with fresh inventory to ensure a wide variety of options are always available. Our inventory management system will track product popularity and adjust stock levels accordingly.

Customer Service:

Our team will be available to address any concerns or inquiries related to the vending machines promptly. We prioritize customer satisfaction and aim to provide a seamless vending experience.

Financial Agreement:

We propose a mutually beneficial financial agreement, which can be tailored to meet your requirements. Commissions are available, however would result in a markup from the base price for the products offered. Based on our conversation, no commission would be provided, we believe this service provides a convenience to your staff, customers, and patrons without imposing any additional financial burden.

By partnering with MM SJ Vending, LLC, you can be assured of reliable vending services that enhance the convenience and satisfaction of everyone at the Municipal Court and DPW. We are committed to delivering excellence in every aspect of our service and look forward to the opportunity to serve.

Please feel free to contact me at 856-209-5959 or via email at info@sjvend.com to discuss this proposal further or to arrange a meeting at your convenience. Thank you for considering our proposal, and we look forward to the possibility of working together.

Sincerely,

Nicole Ahrens
Manager



STATE OF NEW JERSEY BUSINESS REGISTRATION CERTIFICATE

Taxpayer Name: AHRENS, NICOLE
Trade Name: MM SJ VENDING
Address: 612 GRAVELLY HOLLOW RD UNIT H
MEDFORD, NJ 08055
Certificate Number: 2839485
Effective Date: March 24, 2023
Date of Issuance: February 22, 2024

For Office Use Only:

20240222082946087

R-19

SE:dh
03-12-24

RESOLUTION AUTHORIZING THE CITY TO RECEIVE PROPOSALS FOR CONSULTING SERVICES FOR FIVE YEAR CONSOLIDATED PLAN, ONE YEAR ACTION PLAN AND COMPREHENSIVE ANNUAL PERFORMANCE EVALUATION REPORT

WHEREAS, the City of Camden has a need for Consulting Services for the Five Year Consolidated Plan, One Year Action Plan and Comprehensive Annual Performance Evaluation Report; and

WHEREAS, the City of Camden desires to initiate the competitive contracting process to solicit proposals for Consulting Services and

WHEREAS, pursuant to N.J.S.A. 40A:11-4.3, in order to initiate the competitive contracting process, Council of the City of Camden must pass a resolution authorizing the use of the competitive contracting; and

WHEREAS, pursuant to N.J.S.A. 40A:11-4.1m, the Department of Community Affairs Division of Local Government Services must approve the City's use of the competitive contracting process to solicit proposals for Consulting Services; now therefore.

BE IT RESOLVED, by the Council of the City of Camden that the City is hereby authorized to initiate the competitive contracting process to solicit proposals for Consulting Services for the Five Year Plan, One Year Plan, and Comprehensive Annual Performance Evaluation Report.

BE IT FURTHER RESOLVED, that pursuant to N.J.S.A. 52:27BBB-23, a true copy of this Resolution shall be forwarded to the State Commissioner of Community Affairs, who shall have ten (10) days from the receipt thereof to veto this Resolution. All notices of veto shall be filed in the Office of the Municipal Clerk.

Date: March 12, 2024

The above has been reviewed and approved as to form.



DANIEL S. BLACKBURN
City Attorney

ANGEL FUENTES
President, City Council

ATTEST: _____
LUIS PASTORIZA
Municipal Clerk



CITY OF CAMDEN — CITY COUNCIL ACTION REQUEST FORM

COUNCIL MEETING DATE: 03/12/2024

TO: City Council
FROM: Timothy J. Cunningham, Business Administrator

TITLE OF ORDINANCE/RESOLUTION: RESOLUTION AUTHORIZING THE CITY OF CAMDEN TO UTILIZE THE COMPETITIVE CONTRACTING PROCESS TO RECEIVE PROPOSALS FOR CONSULTING SERVICES FOR 5 YEAR CONSOLIDATED PLAN, ONE YEAR ACTION PLAN AND COMPREHENSIVE ANNUAL PERFORMANCE EVALUATION REPORT

Point of Contact:	Lateefah Chandler	Admin-Purchasing	856-757-7475	lachandl@ci.camden.nj.us
	Name	Department-Division-Bureau	Phone	Email

ENDORSEMENTS

Responsible	Recommend Approval (Y/N)	Signature	Date	Comments
Department Director Supporting Department Director (if necessary) Grants Management Qualified Purchasing Agent Director of Finance	Y		2/21/2024	

Approved by:
Business Administrator

Signature

Date

Attachments (list and attach all available):

1. Waiver Request Form Attached for State DCA/DLGS Approval - (If applicable)¹
2. Certification of Funds²
3. Addition supporting documents.

“Walk-on” note: All walk-on legislation must be pre-approved by the Business Administrator. The Department Director and Contact Person are jointly responsible for delivering all necessary documents to the City Clerk for distribution at the Council Meeting.

Received by:
City Attorney

Signature

DATE 2 9 2024

¹ For Example: Form “A” - Request for approval of Employees Requiring Advice and Consent of Governing Body, Form “D” - Contract Request, Form “E” - Creation/Extension of Services, Form “G” - Grant Approval, Form “H” - Bond Ordinance or Contract Request, Form “I”, “Best Price Insurance Contracting” Model Ordinance

² Mandatory for any financial commitment to the City or expenditure of City Funds.

EXECUTIVE SUMMARY

TITLE OF ORDINANCE/RESOLUTION: RESOLUTION AUTHORIZING THE CITY OF CAMDEN TO UTILIZE THE COMPETITIVE CONTRACTING PROCESS TO RECEIVE PROPOSALS FOR CONSULTING SERVICES FOR 5 YEAR CONSOLIDATED PLAN, ONE YEAR ACTION PLAN AND COMPREHENSIVE ANNUAL PERFORMANCE EVALUATION REPORT

FACTS/BACKGROUND: (Executive level details. Short concise bullets)

- Per N.J.S.A 40A:11-4.3(a), governing body approval is required before utilizing the competitive contracting process for services enumerated in N.J.S.A 40A:11-4.1
- N.J.S.A 40A:11-4.1 (m) Consulting Services is an approved specialized goods and services for which competitive contracting can be used.

AMOUNT OF PROPOSED CONTRACT or TOTAL COST OF PROPOSAL: N/A

APPROPRIATION NUMBER: N/A

PROCUREMENT: N/A

IMPACT STATEMENT:

- N/A

SUBJECT MATTER EXPERTS/ADVOCATES:

- N/A

COORDINATION:

- N/A

Prepared by: LATEEAH CHANDLER

856-757-7159

Name

Phone/Email

**STATE OF NEW JERSEY
DEPARTMENT OF COMMUNITY AFFAIRS
DIVISION OF LOCAL GOVERNMENT SERVICES
CONTRACT REQUEST FORM**

This form must be filled out in its entirety and is intended to provide the Division with appropriate information to determine whether to approve a new or extended service. Please provide any additional information you believe will help the Division make an informed decision.

Municipality	CITY OF CAMDEN
--------------	----------------

Professional Service or EUS Type	N/A
Name of Vendor	N/A
Purpose or Need for service:	COMPETITIVE CONTRACTING FOR CONSULTING SERVICES
Contract Award Amount	N/A
Term of Contract	N/A
Temporary or Seasonal	N/A
Grant Funded (attach appropriate documentation allowing for service through grant funds)	N/A
Please explain the procurement process (i.e. bids, RFQ, competitive contracting, etc.)	NJSA 40A:11-4.1 ET SEQ
Were other proposals received? If so, please attach the names and amounts for each proposal received?	N/A

Please attach the RFP, evaluation memoranda or evaluation forms used to evaluate the vendors and a list of all bidders and the bid amounts associated with each bidder.

If the lowest bidder was not selected, please have the appropriate personnel sign the certification on page 2.

Mayor's Signature* Date _____

Business Administrator/Manager Signature Date _____

*For direct appointments of the Governing Body, Council President or at the discretion of the Director, the most senior member of the Governing Body may sign the waiver in lieu of the Mayor.

The Financial Officer affirms that there is adequate funding available for this action.

Financial Officer Signature

I certify that the vendor selected is in compliance with the adopted Pay to Play Ordinance and that the vendor was notified of any restrictions with respect to campaign contributions.

N/A _____ Date _____
Certifying Officer

For LGS use only:

Approved Denied

_____ Date _____
Director or Designee,
Division of Local Government Services

Number Assigned _____

DB:dh
03-12-24

R-20

**RESOLUTION AUTHORIZING RFP SOLUTIONS, INC. TO INSTALL CABLE
AND TELEPHONE WIRING AT THREE COMMUNITY CENTERS
VIA COUNTY COOPERATIVE**

WHEREAS, there exists a need to purchase and have installation of cable and telephone wiring; and

WHEREAS, pursuant to N.J.S.A. 40A:11-11(5) authorizes contracting units to establish a Cooperative Pricing System and to enter into Cooperative Pricing Agreements for its administration; and

WHEREAS, pursuant to the directive of the Division of Local Government Services, a certification has been attached hereto which certifies that the funds for this expenditure are available and appropriated under the budget of the City of Camden under line item "4-01-09-930-872" and said certification has been signed by the Chief Financial Officer and approved as to form by the City Attorney; now, therefore

BE IT RESOLVED by the City Council of the City of Camden, that the contract be awarded to RFP Solutions, Inc. under the Camden County Educational Services Commission #66CCESC, for the installation of cabling and VOIP wiring at three community centers located at Malandra Hall MLK & Isabel Miller Community Center, in the amount of (TBD) according to Public Contracts Law, P.L. 1971, Chapter 198, and that the Mayor and the City Clerk shall execute said contract on behalf of the City of Camden.

BE IT FURTHER RESOLVED, that pursuant to N.J.S.A. 52:27BBB-23, a true copy of this Resolution shall be forwarded to the State Commissioner of Community Affairs, who shall have ten (10) days from the receipt thereof to veto this Resolution. All notices of veto shall be filed in the Office of the Municipal Clerk.

Date: March 12, 2024

The above has been reviewed
and approved as to form.



DANIEL S. BLACKBURN
City Attorney

ANGEL FUENTES
President, City Council

ATTEST: _____
LUIS PASTORIZA
Municipal Clerk



CITY OF CAMDEN — CITY COUNCIL ACTION REQUEST FORM

COUNCIL MEETING DATE: 03/12/2024

TO: City Council
FROM: Timothy J. Cunningham, Business Administrator

TITLE OF ORDINANCE/RESOLUTION: RESOLUTION AUTHORIZING RFP SOLUTIONS, INC TO INSTALL CABLE AND TELEPHONE WIRING AT THREE COMMUNITY CENTERS VIA COUNTY COOPERATIVE

Point of Contact: Lateefah Admin-Purchasing 856-757-7475 lachandl@ci.camden.nj.us
Chandler

Name	Department- Division- Bureau	Phone	Email
Lateefah Chandler	Admin-Purchasing	856-757-7475	lachandl@ci.camden.nj.us

ENDORSEMENTS

Recommend Approval (Y/N)	Signature	Date	Comments
Y		2/21/2024	

- Responsible
- Department Director
- Supporting Department Director (if necessary)
- Grants Management
- Qualified Purchasing Agent
- Director of Finance

Approved by:
Business Administrator

Signature

Date

Attachments (list and attach all available):

1. Waiver Request Form Attached for State DCA/DLGS Approval - (If applicable)¹
2. Certification of Funds²
3. Addition supporting documents.

"Walk-on" note: All walk-on legislation must be pre-approved by the Business Administrator. The Department Director and Contact Person are jointly responsible for delivering all necessary documents to the City Clerk for distribution at the Council Meeting.

Received by:
City Attorney

Signature

2/29/2024

Date

¹ For Example: Form "A" - Request for approval of Employees Requiring Advice and Consent of Governing Body, Form "D" - Contract Request, Form "E" - Creation/Extension of Services, Form "G" - Grant Approval, Form "H" - Bond Ordinance or Contract Request, Form "I", "Best Price Insurance Contracting" Model Ordinance

² Mandatory for any financial commitment to the City or expenditure of City Funds.

EXECUTIVE SUMMARY

TITLE OF ORDINANCE/RESOLUTION: RESOLUTION AUTHORIZING RFP SOLUTIONS, INC TO INSTALL CABLE AND TELEPHONE WIRING AT THREE COMMUNITY CENTERS VIA COUNTY COOPERATIVE

FACTS/BACKGROUND: (Executive level details. Short concise bullets)

- Due to the renovations of the 3 new community centers, new cabling and telephone wiring is needed throughout. RFP Solutions, Inc., 10-F- Greenwood Ave, Woodbury, NJ 08096 via Camden County Educational Services Commission #66CCESC will install cabling and VOIP wiring at Malandra Hall, MLK & Isabel Miller Community Centers

AMOUNT OF PROPOSED CONTRACT or TOTAL COST OF PROPOSAL: TBD

APPROPRIATION NUMBER: 4-01-09-930-872

PROCUREMENT: N.J.S.A. 40A11-11(5)

IMPACT STATEMENT:

- Project will complete the rehab of the 3 community centers. Currently, staff is unable to connect to the internet or receive phone calls due to missing or no lines (new offices)

SUBJECT MATTER EXPERTS/ADVOCATES:

- N/A

COORDINATION:

- N/A

Prepared by: LATEEAH CHANDLER

856-757-7159

Name

Phone/Email

**STATE OF NEW JERSEY
DEPARTMENT OF COMMUNITY AFFAIRS
DIVISION OF LOCAL GOVERNMENT SERVICES
CONTRACT REQUEST FORM**

This form must be filled out in its entirety and is intended to provide the Division with appropriate information to determine whether to approve a new or extended service. Please provide any additional information you believe will help the Division make an informed decision.

Municipality	CITY OF CAMDEN
--------------	----------------

Professional Service or EUS Type	N/A
Name of Vendor	RFP SOLUTIONS, INC
Purpose or Need for service:	INSTALLATION OF CABLING AND TELEPHONE WIRING THROUGHOUT MALANDRA HALL, MLK & ISABEL MILLER COMMUNITY CENTERS
Contract Award Amount	TBD
Term of Contract	~3 MONTHS
Temporary or Seasonal	N/A
Grant Funded (attach appropriate documentation allowing for service through grant funds)	N/A
Please explain the procurement process (i.e. bids, RFQ, competitive contracting, etc.)	N.J.S.A. 40A11-11(5)
Were other proposals received? If so, please attach the names and amounts for each proposal received?	NO

Please attach the RFP, evaluation memoranda or evaluation forms used to evaluate the vendors and a list of all bidders and the bid amounts associated with each bidder.

If the lowest bidder was not selected, please have the appropriate personnel sign the certification on page 2.

Mayor's Signature*

Date _____

Business Administrator/Manager Signature

Date _____

Revised
R-21

MBS:dh
03-12-24

RESOLUTION AWARDING A CONTRACT FOR EXTRAORDINARY UNSPECIFIABLE SERVICES WITH DILORENZO DAVIS CONSULTING, LLC AND THE LATIN AMERICAN ECONOMIC DEVELOPMENT ASSOCIATION, INC FOR THE BUY CAMDEN FIRST INITIATIVE IN THE AMOUNT NOT TO EXCEED \$185,313.50 WITH THE USE OF AMERICAN RESCUE PLAN STATE LOCAL FISCAL RECOVERY FUNDS

WHEREAS, the City of Camden requires certain extraordinary, unspecifiable services for the provision of specialized technology services for the City of Camden; and

WHEREAS, **DILORENZO DAVIS CONSULTING, LLC** and **LATIN AMERICAN ECONOMIC DEVELOPMENT ASSOCIATION, INC.**, has extensive expertise, training and proven reputation in this field and the necessary trained personnel to provide the required services; and

WHEREAS, pursuant to N.J.S.A. 40:A:11-5(1)(a)(ii) of the Local Public Contracts Law, contracts for extraordinary, unspecifiable services to provide a portal listing Camden and local businesses and organizations with the intent to connect these companies with various business opportunities in and around Camden City, can be negotiated and awarded without advertising for bids and bidding therefore; and

WHEREAS, pursuant to the directive of the Division of Local Government Services, a certification has been attached hereto stating the City's reasons for awarding this contract pursuant to N.J.S.A. 40A:11-5(1)(a)(ii), and said certification has been signed by the Purchasing Agent; and

WHEREAS, pursuant to the directive of the Division of Local Government Services, a certification has been attached hereto which certifies that the funds for this expenditure are available and appropriated under the state and federal grant budget of the City of Camden under line item "G-02-FF-712-20Q" and said certification has been signed by the Chief Financial Officer and approved as to form by the City Attorney; now, therefore

BE IT RESOLVED, by the City Council of the City of Camden that a contract be awarded to **Dilorenzo Davis Consulting, LLC** and **the Latin American Economic Development Association, Inc.**, for a sum not to exceed ONE HUNDRED EIGHTY-FIVE THOUSAND THREE HUNDRED THIRTEEN DOLLARS AND FIFTY CENTS (\$185,313.50).

BE IT FURTHER RESOLVED that the authorized City officials are hereby authorized to negotiate and enter into an appropriate contract with **Dilorenzo Davis Consulting, LLC** and **the Latin American Economic Development Association, Inc.** for the construction of BuyCamdenFirst.com; provide pre-screening and technical assistance for businesses to become Camden Verified; and gain the support of local based corporation and anchor institutions for the initiative.

BE IT FURTHER RESOLVED that the City Clerk shall cause to be published in the Courier-Post within ten (10) days after passage of this resolution legal notice describing the nature, duration and amount of said contract.

BE IT FURTHER RESOLVED, that pursuant to N.J.S.A. 52:27BBB-23, a true copy of this Resolution shall be forwarded to the State Commissioner of Community Affairs, who shall have ten (10) days from the receipt thereof to veto this Resolution. All notices of veto shall be filed in the Office of the Municipal Clerk.

Date: March 12, 2024

The above has been reviewed
and approved as to form.



DANIEL S. BLACKBURN
City Attorney

ANGEL FUENTES
President, City Council

ATTEST: _____
LUIS PASTORIZA
Municipal Clerk



CITY OF CAMDEN — CITY COUNCIL ACTION REQUEST FORM

COUNCIL MEETING DATE: 03/12/2024

TO: City Council
FROM: Timothy J. Cunningham, Business Administrator

TITLE OF ORDINANCE/RESOLUTION: RESOLUTION AWARDING A CONTRACT FOR EXTRAORDINARY UNSPECIFIABLE SERVICES WITH DILORENZO DAVIS CONSULTING, LLC AND THE LATIN AMERICAN ECONOMIC DEVELOPMENT ASSOCIATION, INC FOR THE BUY CAMDEN FIRST INITIATIVE IN THE AMOUNT NOT TO EXCEED \$185,313.50 WITH THE USE OF AMERICAN RESCUE PLAN STATE LOCAL FISCAL RECOVERY FUNDS

Point of Contact: Lateefah Chandler
Admin-Purchasing 856-757-7475 lachandl@ci.camden.nj.us
Name Department- Division- Bureau Phone Email

ENDORSEMENTS

Table with columns: Recommend Approval (Y/N), Signature, Date, Comments. Rows include Responsible Department Director, Supporting Department Director, Director of Grants Management, Qualified Purchasing Agent, and Director of Finance.

Approved by: Business Administrator
Signature: [Handwritten Signature]
Date: 3.4.24

Attachments (list and attach all available):

- 1. Waiver Request Form Attached for State DCA/DLGS Approval - (If applicable)1
2. Certification of Funds2
3. Addition supporting documents.

Walk-on note: All walk-on legislation must be pre-approved by the Business Administrator. The Department Director and Contact Person are jointly responsible for delivering all necessary documents to the City Clerk for distribution at the Council Meeting.

Received by: City Attorney
Signature: [Handwritten Signature]
Date: 3.4.24

1 For Example: Form "A" - Request for approval of Employees Requiring Advice and Consent of Governing Body, Form "D" - Contract Request, Form "E" - Creation/Extension of Services, Form "G" - Grant Approval, Form "H" - Bond Ordinance or Contract Request, Form "I", "Best Price Insurance Contracting" Model Ordinance
2 Mandatory for any financial commitment to the City or expenditure of City Funds.

EXECUTIVE SUMMARY

TITLE OF ORDINANCE/RESOLUTION: RESOLUTION AWARDING A CONTRACT FOR EXTRAORDINARY UNSPECIFIABLE SERVICES WITH DILRENZO DAVIS CONSULTING, LLC AND THE LATIN AMERICAN ECONOMIC DEVELOPMENT ASSOCIATION, INC FOR THE BUY CAMDEN FIRST INITIATIVE IN THE AMOUNT NOT TO EXCEED \$185,313.50 WITH THE USE OF AMERICAN RESCUE PLAN STATE LOCAL FISCAL RECOVERY FUNDS

FACTS/BACKGROUND: (Executive level details. Short concise bullets)

- Latin American Economic Development Association (LAEDA) and DiLorenzo Davis will provide the following services for 2024: complete the construction of BuyCamdenFirst.com; provide pre-screening and technical assistance for businesses to become Camden Verified; and gain the support of local based corporations and anchor institutions for the initiative.
- Buy Camden First Initiative includes:
 - Construction of a website with a listing of local businesses and their Camden Verified Status
 - Outreach to owners of local businesses to register to the portal and bring awareness to the opportunities available from this initiative.
 - Link with key corporations and institutions to both post and procure, via BuyCamdenFirst.com, goods and services from these registered businesses.

AMOUNT OF PROPOSED CONTRACT or TOTAL COST OF PROPOSAL: \$185,313.50

APPROPRIATION NUMBER: G-02-FF-712-20Q

PROCUREMENT: N.J.S.A 40A:11-5(1)(a)(ii)

IMPACT STATEMENT:

- The goal of this partnership is a welcoming and inclusive reason for businesses to register to BuyCamdenFirst.com. Registration to the portal will help promote the purchase of products and services from Camden-based businesses and will also serve as a catalyst to job creation, small business expansion and new business startups in the city.

SUBJECT MATTER EXPERTS/ADVOCATES:

- Timothy J. Cunningham, Business Administrator

COORDINATION:

- N/A

Prepared by: LATEEAH CHANDLER

856-757-7475

Name

Phone/Email

**STATE OF NEW JERSEY
DEPARTMENT OF COMMUNITY AFFAIRS
DIVISION OF LOCAL GOVERNMENT SERVICES
CONTRACT REQUEST FORM**

This form must be filled out in its entirety and is intended to provide the Division with appropriate information to determine whether to approve a new or extended service. Please provide any additional information you believe will help the Division make an informed decision.

Municipality	CITY OF CAMDEN
Professional Service or EUS Type	EUS
Name of Vendor	LAEDA & DILORENZO DAVIS CONSULTING
Purpose or Need for service:	EUS FOR BUY CAMDEN FIRST INITIATIVE
Contract Award Amount	\$185,313.50
Term of Contract	9 MONTHS
Temporary or Seasonal	N/A
Grant Funded (attach appropriate documentation allowing for service through grant funds)	NO
Please explain the procurement process (i.e. bids, RFQ, competitive contracting, etc.)	N.J.S.A 40A:11-5(1(a)(ii)
Were other proposals received? If so, please attach the names and amounts for each proposal received?	NO

Please attach the RFP, evaluation memoranda or evaluation forms used to evaluate the vendors and a list of all bidders and the bid amounts associated with each bidder.

If the lowest bidder was not selected, please have the appropriate personnel sign the certification on page 2.

Mayor's Signature

Date _____

Business Administrator/Manager Signature

Date _____

*For direct appointments of the Governing Body, Council President or at the discretion of the Director, the most senior member of the Governing Body may sign the waiver in lieu of the Mayor.

The Financial Officer affirms that there is adequate funding available for this action.

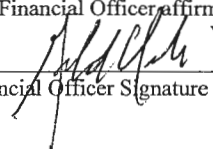
Financial Officer Signature

I certify that the vendor selected is in compliance with the adopted Pay to Play Ordinance and that the vendor was notified of any restrictions with respect to campaign contributions.

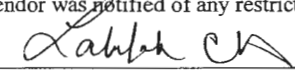
Certifying Officer

Date 3/4/2024

For LGS use only:

Approved

Denied

_____ Date _____

Director or Designee,
Division of Local Government Services

Number Assigned _____

**STANDARD CERTIFICATION DECLARATION FOR AN EXTRAORDINARY
UNSPECIFIABLE SERVICE**

TO: Members of the Governing Body
FROM: L. Chandler, Purchasing Agent
DATE: March 1, 2024
SUBJECT: This is a contract for Non-Fair and Open / EUS

This is to request your approval of a resolution authorizing a contract to be executed as follows:

Firm: Latin American Economic Development Association, Inc. (LAEDA)
and DiLorenzo Davis Consulting, LLC
Cost: \$185,313.50
Duration: One Year
Purpose: Buy Camden First Initiative

This is to request an award of a contract without the receipt of formal bids as an Extraordinary Unspecifiable Service [N.J.S.A. 40A:11-5(i)(a)(ii) and N.J.A.C. 5:34-2.3(b)]. I do hereby certify to the following:

1. Provide a clear description of the nature of the work to be done.

LAEDA and DiLorenzo Davis Consulting, LLC will provide the following services for 2024: complete the construction of BuyCamdenFirst.com; provide pre-screening and technical assistance for businesses to become Camden Verified; and gain the support of local based corporations and anchor institutions for the initiative.

DiLorenzo Davis Consulting will oversee the construction of a user-friendly website, BuyCamdenFirst.com, to include a listing of businesses and of these businesses, which ones are Camden Verified along with allowing visitors the ability to search and post purchasing and procurement opportunities. DiLorenzo Davis Consulting LLC will outreach to Camden's small businesses to encourage the owners to register their business on the website and eventually achieve a Camden Verified status. Outreach efforts consist of direct mail, email, advertising, social media, leveraging key partners and the efforts/programs of the Mayor & his administration to increase awareness and support of the website once live. In addition to continuous outreach, DiLorenzo Davis Consulting, LLC will build support of anchor institutions and corporations to utilize the Buy Camden First website for the purchase of goods and services and/or the posting of procurement and purchase opportunities.

Throughout, LAEDA will support DiLorenzo Davis with outreach and marketing activities via their exhaustive contacts. LAEDA's Camden Verified Coordinator will lead the charge on approving businesses to Camden Verified Status. Once the website is built, LAEDA will provide ongoing management and maintenance of the website.

2. Describe in detail why the contract meets the provisions of the statute and rules:

DiLorenzo Davis Consulting LLC has 80 years of experience in the public, private and non-profit sections and throughout have confronted many issues essential to business communities including the City of Camden's desire to increase the funding and procurement opportunities of Camden City small businesses. DiLorenzo Davis' decades long connection with the City includes programs centered around linking the city's small business community with key institutions or organizations to promote business-to-business opportunities.

LAEDA, a non profit organization with 35 years of experience with local community vendors, has helped create jobs, contributed to improving the City's public infrastructure, and invested in the community both socially and economically. Together, LAEDA & DiLorenzo Davis Consulting, LLC intends to provide a portal that allows companies, corporations, governments and institutions in and around the city to focus their purchasing power, safely, securely and confidently, through Camden-based businesses.

3. The service(s) is of such a specialized and qualitative nature that the performance of the service(s) cannot be reasonably described by written specifications because:

This unique collaboration will source a platform that will help promote the purchase of products and services from Camden-based businesses and will serve as a catalyst to job creation, small business expansion and new business startups in the City. This is a multi-phase project that hinges on the developed portal that DiLorenzo Davis Consulting, LLC will create and the 35 years of extensive knowledge and experience LAEDA obtained by assisting minority businesses in Camden to develop efficient business plans.

4. Describe the informal solicitation of quotations:

Because this multi-phase concept is unique to the City of Camden, we do not have any exact comparisons to quote. However, the solution to help bolster the success of Camden businesses was developed after many roundtable talks between local/county stakeholders, and various other organizations.

5. I have reviewed the rules of the Division of Local Government Services pursuant to N.J.A.C. 5:34-2.1 et seq. and certify that the proposed contract may be considered an extraordinary unspicifiable service in accordance with the requirements thereof.

Respectfully,

Name Kateeteh Chandler, Purchasing Assistant
Title

(Signature)

(Original to be retained by governing body's Clerk with the affirmed copy of the resolution; signed duplicate to be kept by appropriate official.)



Buy Camden First Initiative

Proposal submitted by:

The Latin American Economic Development Association, Inc.

And

DiLorenzo Davis Consulting, LLC

March 1, 2024

Overview

This proposal is submitted by the Latin American Economic Development Association (LAEDA) and DiLorenzo Davis Consulting, LLC to implement Camden City's "Buy Camden" ordinance. Passed by City Council in March 2021, Buy Camden urges the City, corporations and anchor institutions to purchase goods and services from Camden City businesses, especially small businesses. This proposal lays out the blueprint for the **Buy Camden First** initiative.

The goal in 2024 is to complete construction of BuyCamdenFirst.com; list a critical mass of small businesses on the website; provide pre-screening and technical assistance for businesses to become Camden Verified; and gain the support of Camden based corporations and anchor institutions for the initiative.

The implementation plans for the initiative include: building the BuyCamdenFirst.com website, including a searchable database of small businesses in the City and information on those businesses, per their submission of an intake survey; providing technical assistance to small businesses, including helping them achieve Camden Verified status on the website; building support of anchor institutions and corporations to utilize the Buy Camden First website for purchasing their goods and services; enabling anchor institutions and corporations to post procurement and purchasing opportunities on the Buy Camden First website; and increasing overall awareness of Buy Camden First throughout the greater community.

The program outreach to the City's small businesses will ensure a welcoming, inclusive and compelling reason for participation in Buy Camden First. Every effort will be made to reach minority, women and veteran owned businesses, as well as micro-enterprises, while ensuring the process for listing on the Buy Camden First website and gaining Camden Verified status is straightforward and as easy to complete as possible.

A multi-pronged approach to encourage small businesses to participate in the initiative by completing an initial intake survey includes direct mail, email, social media, advertising and leveraging key partners to spread the word.

Upon receipt of completed surveys, LAEDA begins the process of confirming the business information and listing it on the Buy Camden First website. Each business will then be invited to participate in the Camden Verified process. As a result of this process, "Verified" businesses will have a badge graphic added to their listing.

Equally important to the success of the Buy Camden First initiative is securing the commitment of the City's corporations and anchor institutions to support Buy Camden First by utilizing the website/business portal for procurement/purchasing and to post their procurement opportunities.

Efforts to gain that commitment and ensure use of the business portal for procurement and purchasing includes communications with 30+ larger companies and institutions in the City and providing regular updates to and communications with the procurement and other purchasing representatives within those organizations, including hosting a meeting of the representatives to educate them about the Buy Camden First initiative. Additionally, a Purchasing/Procurement event will be held in the fourth quarter of the year, which will include a panel discussion and opportunities for small business-people to meet one-on-one with the procurement/purchasing professionals from anchor institutions and corporations.

The partners are committed to and have built solid plans that will: reach the City's small businesses, persuade businesses to complete the initial intake survey that will guarantee a listing on BuyCamdenFirst.com, provide them with a straightforward process to become Camden Verified and provide the City's large companies and institutions with information on companies in a searchable database via a newly created website.

Buy Camden First Initiative

The implementation of the Buy Camden First initiative is an integration of plans between the two partners, LAEDA and DiLorenzo Davis Consulting, LLC, to carry out the City of Camden's vision of strengthening the City's small business sector.

LAEDA

LAEDA's proposal includes five areas of work with:

- **Support DiLorenzo Davis Consulting, LLC's (DDC) Outreach & Marketing Activities -** LAEDA will support DDC's outreach and marketing activities by tapping into its networks and constituencies to advance awareness and garner participation in the Buy Camden First Initiative.
- **Managing Camden Verified Process -** LAEDA has developed the infrastructure and procedures required to execute the Camden Verified process. LAEDA has hired Mefred Feliz as its Camden Verified Coordinator, who will lead this process.

Outcomes: LAEDA expects marketing efforts to generate 160 - 200 prospective leads, of which 75 - 100 initial consultations will be completed. 50 - 75 will begin the verification process, 40 - 60 of which will complete the process and attain Camden Verified Status.

- **Matchmaking Assistance -** In addition to coordinating the verification process, Ms. Feliz will work with anchor corporations and institutions and Camden Verified businesses to connect and conduct business. Where technical assistance is required, Ms. Feliz will provide assistance while also engaging the LAEDA team of business counselors where needed.

Outcomes: LAEDA will successfully complete between 7 - 14 purchasing transactions

- **Capacity Building Assistance -** LAEDA will produce capacity building business education opportunities to support the development of Camden Verified businesses to do business with anchor corporations and institutions. In addition, one on one counseling services will be made available to provide specific assistance.

Outcomes: LAEDA will host 4 Procurement Capacity Building Seminars around General Readiness, Certifications, Capability Statements and Finance

- **Ongoing Management of the Buy Camden First Website** - Once the BuyCamdenFirst.com site is built, LAEDA will manage the update and maintenance of the site to include adding business listings, posting purchasing opportunities and maintaining the site's calendar and news blog.

DiLorenzo Davis Consulting, LLC

DiLorenzo Davis Consulting, LLC's proposal includes three distinct, equal and concurrent segments:

- **Outreach to Camden's small businesses** encouraging them to become listed on the Buy Camden First business portal, and to become Camden Verified via: direct mail, email, advertising, social media, leveraging key partners to spread the word, and supporting and building on the Mayor's and Administration's efforts on the program.
- Creating awareness and **ensuring support and commitment of anchor institutions and corporations** to use the website to do business with companies located in Camden City; and
- Oversee the **construction of a user-friendly website** that will include information on businesses that choose to be listed on the business portal, businesses that are Camden Verified, and that allows corporations and anchor institutions to post information on RFPs, RFQs, etc.

1. Outreach to Camden's small businesses encouraging them to become listed on the Business Portal "BuyCamdenFirst.com" by completing initial intake survey and to become Camden Verified.

Direct outreach to businesses via mail and email:

- Build robust list of licensed City businesses by identifying business classifications most likely to offer goods and services needed by anchor institutions and corporations; build mailing and email lists of those businesses. Consultants will research missing email addresses, making every effort to reach as many businesses as possible.
- Design Initial Intake Survey including: Business name, address, phone number, email, business certifications (Small, minority, women owned, etc.) website, social media sites, main contact, title/position in the business, number of employees, # of years in business, business classification and brief description of the business.
- **Deliverables: Email and mailing lists completed and shared with City and LAEDA; survey instrument completed.**

- Facilitate drafting of letter from Mayor to small businesses announcing program and encouraging participation.
- Facilitate email distributed by LAEDA explaining the initiative and encouraging participation.
- Work with designer to prepare and print a one-page promotional piece for inclusion with letters and emails.
- Distribution of promotional piece at key City-sponsored events and made available at designated offices in City Hall (Licenses & Inspections, Economic Development), as well as at events of partners.
- Oversee creation of logo for Buy Camden First and Camden Verified badge graphic.
- **Deliverables: Letter/email finalized and sent by City and LAEDA; promotional piece completed and printed; new logo and Camden Verified badge graphic completed.**

Media Relations & Social Media: Increase awareness in the community of the Buy Camden First Program

- Draft initial press release announcing the initiative, its benefits, who should participate, and a link to Buy Camden First website landing page.
- Draft three additional news releases highlighting progress of Buy Camden First program.
- Identify relevant publications for placement of news articles about Buy Camden First; write copy where needed; follow up for placement.
- Identify publications and work with designer to create advertisement for purchase in local papers of record and other local and hyper local publications.
- Work with Social Media professional to write and update posts on various platforms.
- **Deliverables: News releases and articles drafted; advertisement designed and placed in publications; social media campaign underway.**

Gain the support of key partners to spread the word about the initiative; work with Mayor's office to support promotion of Buy Camden First initiative.

- Identify and request key partners announce the initiative in their publications, public comments, email distribution to their members, and allow consultants & LAEDA to make presentations.
- Prepare key messages for partners, including writing verbiage for print pieces, and emails to their mailing lists (including promotional piece).
- Identify and reach out to other City-based business organizations, non-profits, faith-based, etc. organizations to identify opportunities to speak about the program; request placement of written pieces on their website/in newsletter/email to their distribution lists.
- Work with Mayor's office to identify opportunities for Mayor and other City officials to talk about the initiative in public forums.

- Plan press conference(s) with Mayor at appropriate time: e.g., unveiling logo and website.
- Provide key messages on why companies should participate – both as a business selling goods and services and as a purchaser of goods and services.
- **Deliverables: Outreach to partners completed; key messages and verbiage drafted; press conference held (timeframe TBD).**

2. Create awareness and ensure support and commitment of anchor institutions and corporations to use the website to do business with companies located in Camden City; provide regular communication with procurement and purchasing representatives in these organizations about the initiative.

- Hold meetings with small group of procurement and purchasing representatives from corporations to gain feedback on Buy Camden First procurement portal and Camden Verified process.
- Outreach to anchor institutions and corporations requesting support for and providing updates on Buy Camden First; request CEO/leaders to identify purchasing representative in their organization for future outreach; conduct follow up communication with these organization to identify procurement/purchasing representatives.
- Identify and reach out to other corporations and anchor institutions in the City describing the initiative and inviting them to participate.
- Provide regular updates to procurement and purchasing representatives on the initiative.
- Plan and coordinate meeting with procurement/purchasing representatives from anchor institutions and corporations to unveil Camden Verified process; encourage them to post information on their purchasing opportunities on website.
- **Deliverables: Initial meetings held with four companies; feedback supplied to LAEDA on Camden Verified process and requirements. Email communication completed and follow up with corporations and anchor institutions on designation of procurement representatives in their organization. At least three email communications sent to procurement/purchasing representatives with initiative updates; meeting with procurement/purchasing representatives held.**
- Plan and implement Procurement/Purchasing Event to connect small businesses with purchasing/procurement representatives from corporations and anchor institutions to identify opportunities to do business together; agenda will include a panel discussion comprised of top purchasing representatives, followed by opportunities for small business representatives to meet one-on-one with them, as well as purchasing representatives from other companies.
- **Deliverable: Event planned and held.**

3: Oversee the construction of a user-friendly website that will include information on businesses that choose to be listed on the business portal via initial intake survey, businesses that have completed the Camden Verified process; and that allows the anchor institutions and corporations to post purchasing opportunities.

- Identify and meet with potential website developer.
 - Work with developer on design and requirements of landing page and other pages of the website including: searchable database of Camden City businesses and Camden Verified businesses; listing of purchasing opportunities; About Buy Camden First; resources for small businesses; and news & events.
 - Write content for website.
 - Work with LAEDA to develop Spanish language version of pages.
- **Deliverables: Landing page of website built and operational, including link to initial intake survey; other pages completed or under construction.**

Anticipated Outcomes:

The Buy Camden First initiative as implemented by the partners in 2024 is anticipated to begin end of the first quarter. Outcomes are based upon approximately 1,000 licensed businesses in the City, almost 80% of which are projected to be included in initial mailing and other outreach.

While those 800 businesses will receive the initial letter by mail, a segment of those businesses will also receive emails and regular email communications will be ongoing with those businesses for whom emails can be determined.

By December 31, 2024, 160-200 businesses will have completed the intake survey.

Budget Narrative:

The budget narrative is comprised of two parts. Part I - LAEDA's proposed budget expenses and Part II DiLorenzo Davis Consulting, LLC's. The total funding request for the implementation of the Buy Camden First Initiative is \$185,313.50.

LAEDA Budget Narrative - \$75,813.50

Personnel – The expenses in this section represent the allocation of time for the execution of the CV over a 9 month timeframe.

- **LAEDA Operations**
 - **President & CEO** - \$7,000 represents the time the CEO will allocate to the project to oversee its implementation and grants management.
 - **Office Administrator** - \$2,000 represents the time the office administrator will allocate to the project for grants management and client engagement.
- **LAEDA Business Services**
 - **Program Manager** - \$5,000 – represents the time the program manager will allocate to developing and hosting trainings as part of the CV.
 - **Camden Verified Coordinator** - \$33,750 – represents the full-time salary paid to coordinator for managing the day-to-day processing of inquiries and completing verifications. This is 9 months of a \$45,000 annual salary.
- **LAEDA Women's Business Center**
 - **Program Manager** - \$6,000 – represents the time the program manager will allocate to coordinating and providing counseling services to CV clients.
 - **Assistant Program Manager** - \$5,000 – represents the time the assistant program manager will allocate to providing counseling services to CV clients.
- **Employer Contributions** - \$5,287.50 - This line represents the employer payroll contribution due based on the total wages paid at 9%.
- **Fringe Benefits** - \$8,000 - This line represents Health & Dental Benefits provided by the employer. The amount represent the total annual premium for the Camden Verified Coordinator.

Operating Expenses – The expenses in this section represent the apportionment of expenses incurred or outright purchases of goods and services to execute the Camden Verified component (CV) of the Buy Camden First Initiative.

- **Purchase Domains** – \$500 - This expense represents the costs associated with purchasing the domains – BuyCamdenFirst.com, .org and .net., BuyCMD1st.com, .org and .net. This is to ensure no one will be able to purchase a copy cat url.

- **Web Hosting – \$1,200** - This expense represents the costs associated with the purchase of hosting services for a three year period.
- **Client Relationship Management Software – \$550** – This expense represents an apportionment of LAEDA’s licensing fee of its CRM to the project for use in recording client counseling engagements and managing client movement through the program.
- **Payroll Fees - \$326** – This expense represents the apportionment of payroll fees incurred by LAEDA for payroll processing.
- **Travel - \$350** – This expense represents travel expense for the use of personal vehicles in the execution of the project.
- **Consultant/Instructors – Training - \$600** – This expense represents the cost of instructional fees to be paid to consultants to provide instruction through LAEDA’s Getting Started in Procurement program.
- **E-mail Marketing Subscriptions - \$250** – This expense represents apportionments of e-mail marketing subscription fees to the project for promotion.

DiLorenzo Davis Consulting, LLC – Budget Narrative - \$109,500

Each segment of DiLorenzo Davis Consulting, LLC’s proposal is budgeted based upon the time both consultants will spend to produce deliverables, as well as other determinable costs.

- **Outreach to small businesses: \$30,750**
 Consultants’ time = 123 hours
 Includes: Building list of businesses for outreach; design of initial intake survey; letters and emails to businesses; one-page promotional piece about Buy Camden First; new logo; media and social media relations; advertising copy; outreach to partner organizations; support for Mayor’s efforts to publicize Buy Camden First.
Other costs: Printing of one-page promotional piece: \$2,500
 Ad buy: \$12,000
- **Obtaining/ensuring commitment of corporations and anchor institutions: \$12,500**
 Consultants’ time = 50 hours
 Includes: Outreach to anchor institutions and corporations via email and phone calls; identifying procurement and purchasing reps in each organization; regular outreach to purchasing representatives; meeting of purchasing/procurement reps to educate on Buy Camden First initiative; plan and hold purchasing event.
Other costs: Event for procurement/purchasing reps - \$2,000
 Procurement/purchasing event \$6,000
- **Construction of BuyCamdenFirst.com: \$8,750**
 Consultants’ time = 35 hours
 Includes: Overseeing construction to ensure elements of website are completed; write content; include Spanish language version of website.
Other costs: Website developer \$35,000

Budget

Income	Budget
Funding Sources	
Government Contracts	
City of Camden	185,313.50
	-
Total Government Contracts	185,313.50
Total Income	185,313.50
Expenses	
Personnel	
Salaries	
Operations - President & CEO	7,000.00
Operations - Office Administrator	2,000.00
Business Svcs. - Program Manager	5,000.00
Business Svcs. - Camden Verified Coordinator	33,750.00
WBC - Program Manager	6,000.00
WBC - Assistant Program Manager - Counseling	5,000.00
Total Salaries	58,750.00
Employer Contributions & Fringe Benefits	
Payroll Taxes - Employer Match - 9%	5,287.50
Fringe Benefits - Health & Dental Insurance	8,000.00
Total Employer Contributions & Fringe Benefits	13,287.50
Total Personnel Expense	72,037.50
Operating Expenses	
LAEDA - Purchase Domain	500.00
LAEDA - Website Hosting - Three Years	1,200.00
LAEDA - Client Relationship Management Software	550.00
LAEDA - Payroll Fees	326.00
LAEDA - Travel	350.00
LAEDA - Consultants/Instructors - Training	600.00
LAEDA - Email Marketing Subscription	250.00
Dilorenzo Davis (DD) Consulting Fees:	
Segment 1: Outreach to Small Businesses	\$30,750
Segment 2: Ensure Support of Corporations & Institutions	\$12,500
Segment 3: Oversee Construction of Website	\$8,750
DD - Web Development/Portal Webmaster	\$35,000.00
DD - Advertising Buy Expenses	\$12,000
DD - Printing and Reproduction - Flyers, Materials, etc.	\$2,500
DD - Procurement Event	\$6,000
DD - Event for Purchasing Reps	\$2,000
	-
Total Project Expenses	185,313.50

ABOUT THE PARTNERS

LAEDA

The Latin American Economic Development Association, Inc. (LAEDA) is a community economic development organization founded in 1987. LAEDA is dedicated to the revitalization of underserved low wealth urban communities in South Jersey. LAEDA leverages its entrepreneurship mission to advance community economic development strategies in these communities.

DiLorenzo Davis Consulting, LLC

DiLorenzo Davis Consulting, LLC is a woman-owned consulting firm specializing in issues management and strategic communications with the community, stakeholders and government, as well as business event planning. The two principals, Debra P. DiLorenzo and Kathleen A. Davis, possess a combined 80 years of experience in the public, private and non-profit sectors. Throughout their careers, they have tackled hundreds of issues critical to the business community, including the City of Camden and its small business sector.

In their quarter century-long tenure serving the business community as the two top leaders of the Chamber of Commerce Southern New Jersey, DiLorenzo and Davis propelled the CCSNJ to become the region's largest, most active and influential business organization.

Their decades-long connection to Camden includes a history of leading programs that supported the City during lean economic times and into the current era of economic growth. During their time at the CCSNJ, they led the organization's support for Camden, its businesses and residents by planning numerous Camden-centric events. In 2017, they partnered with the City's administration and oversaw the creation of CCSNJ's "Committed to Camden Committee." This Committee linked the City's small business community with the top leaders of the largest companies to promote business-to-business opportunities.

Contact information:

The Latin American Economic Development Association, Inc.
Raymond Lamboy, CEO
433 Market Street – Suite 202
Camden, NJ 08102
rlamboy@laeda.com
856-338-1177
www.laeda.com

DiLorenzo Davis Consulting, LLC
Debra P. DiLorenzo, Principal
Kathleen A. Davis, Principal
101 North Washington Ave., Suite 6
Margate, NJ 08402
deb@dilorenzodavis.com
kathy@dilorenzodavis.com
609-870-2775
609-870-5587
www.dilorenzodavis.com



STATE OF NEW JERSEY
BUSINESS REGISTRATION CERTIFICATE

Thrupayer Name:	DILORENZO DAVIS CONSULTING LLC
Trade Name:	
Address:	101 NORTH WASHINGTON AVE. SUITE 6 MARGATE, NJ 08402
Certificate Number:	2416577
Effective Date:	January 13, 2020
Date of Issuance:	January 02, 2024

For Office Use Only:
20240102132045416



**STATE OF NEW JERSEY
BUSINESS REGISTRATION CERTIFICATE**

Taxpayer Name: LATIN AMERICAN ECONOMIC DEVELOPMENT
ASSOCIATION, INC.
Trade Name:
Address: 433 MARKET ST STE 202
CAMDEN, NJ 08102
Certificate Number: 0528417
Effective Date: March 08, 1989
Date of Issuance: February 06, 2024

For Office Use Only:
20240206133927883

R-22

DB:dh
03-12-24

**RESOLUTION AUTHORIZING THE SUBMISSION OF AN APPLICATION TO THE
NEW JERSEY DEPARTMENT OF COMMUNITY AFFAIRS LOCAL RECREATION
IMPROVEMENT 2024 PROGRAM**

WHEREAS, the City of Camden desires to apply for and obtain a grant from the New Jersey Department of Community Affairs for the renovation of the North Camden Community Pool to include replacing main drain line to resolve leak and resurfacing of the pool along with replacing skimmers, upgrading pool filter building, water valves, and water fountain; now, therefore

BE IT RESOLVED, by the City Council of the City of Camden that the City does hereby authorize the proper officials of the City of Camden to submit the application for the FY 2024 Local Recreation Improvement Grant from the New Jersey Department of Community Affairs in accordance with all pertinent terms, conditions and requirements which may be established for such an application.

BE IT FURTHER RESOLVED, by the City Council of the City of Camden:

- 1) that the City of Camden does hereby authorize the application for such grant; and
- 2) recognizes and accepts that the Department may offer a lesser or greater amount and therefore upon receipt of the grant agreement from the New Jersey Department of Community Affairs, does further authorize the execution of any such grant agreement; and
- 3) also, upon receipt of the fully executed agreement from the Department, does further authorize the expenditure of funds pursuant to the terms of the agreement between the City of Camden and the New Jersey Department of Community Affairs.

BE IT FURTHER RESOLVED, that the Mayor of the City of Camden or his designee are hereby authorized to execute the application, and that they or their successors in said titles are authorized to sign the agreement, and any other documents necessary in connection therewith.

BE IT FURTHER RESOLVED, that pursuant to N.J.S.A. 52:27BBB-23, a true copy of this Resolution shall be forwarded to the State Commissioner of Community Affairs, who shall have ten (10) days from the receipt thereof to veto this Resolution. All notices of veto shall be filed in the Office of the Municipal Clerk.

Date: March 12, 2024

The above has been reviewed
and approved as to form.

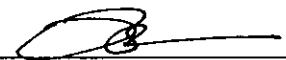

DANIEL S. BLACKBURN
City Attorney

ANGEL FUENTES
President, City Council

ATTEST: _____
LUIS PASTORIZA
Municipal Clerk

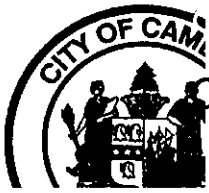

CITY OF CAMDEN — CITY COUNCIL ACTION REQUEST FORM

COUNCIL MEETING DATE: 03/12/2024

TO: City Council
FROM: Timothy J. Cunningham, Business Administrator

TITLE OF ORDINANCE/RESOLUTION: RESOLUTION AUTHORIZING THE SUBMISSION OF AN APPLICATION TO NEW JERSEY DEPARTMENT OF COMMUNITY AFFAIRS' LOCAL RECREATIONAL IMPROVEMENT 2024 PROGRAM

Point of Contact:	Lateefah Chandler	Admin-Purchasing	856-757-7475	lachandl@ci.camden.nj.us
	Name	Department-Division-Bureau	Phone	Email

ENDORSEMENTS

	Recommend Approval (Y/N)	Signature	Date	Comments
Responsible Department Director Supporting Department Director (if necessary) Director of Grants Management	Y			
Qualified Purchasing Agent	Y			
Director of Finance	Y			

Approved by:
Business Administrator

2.28.24

Signature

Date

Attachments (list and attach all available):

1. Waiver Request Form Attached for State DCA/DLGS Approval - (If applicable)¹
2. Certification of Funds²
3. Addition supporting documents.

"Walk-on" note: All walk-on legislation must be pre-approved by the Business Administrator. The Department Director and Contact Person are jointly responsible for delivering all necessary documents to the City Clerk for distribution at the Council Meeting.

FEB 29 2024

Received by:
City Attorney

Signature

Date

¹ For Example: Form "A" - Request for approval of Employees Requiring Advice and Consent of Governing Body, Form "D" - Contract Request, Form "E" - Creation/Extension of Services, Form "G" - Grant Approval, Form "H" - Bond Ordinance or Contract Request, Form "I", "Best Price Insurance Contracting" Model Ordinance
² Mandatory for any financial commitment to the City or expenditure of City Funds.

EXECUTIVE SUMMARY

TITLE OF ORDINANCE/RESOLUTION: RESOLUTION AUTHORIZING THE SUBMISSION OF AN APPLICATION TO NEW JERSEY DEPARTMENT OF COMMUNITY AFFAIRS' LOCAL RECREATIONAL IMPROVEMENT 2024 PROGRAM

FACTS/BACKGROUND: (Executive level details. Short concise bullets)

- The City of Camden is requesting to apply to the DCA Local Recreation Improvement Grant (LRIG). This grant w has a maximum award of \$100,000.00 to support improvement and repair of community centers, playgrounds, pools, fields and recreational facilities. No match is required.
- The City intends to use this grant to rehabilitate the North Camden community pool
- Renovations will include replacing main drain line to resolve leak and resurfacing of the pool along with replacing skimmers, upgrading pool filter building, water valves, and water fountain.

AMOUNT OF PROPOSED CONTRACT or TOTAL COST OF PROPOSAL: N/A

APPROPRIATION NUMBER: N/A

PROCUREMENT: N/A

IMPACT STATEMENT:

- Both pools are in dire need of a rehabilitation. In conjunction with this grant, City bond money and CDBG funds we are hoping to replace and repair various defective, broken and outdated pool components

SUBJECT MATTER EXPERTS/ADVOCATES:

- Keith Walker, Director of Public Works
- Dorri Brown, Interim Director of Housing Services

COORDINATION:

- Dorri Brown, Interim Director of Housing Services
- Kelly Mobley, Grants Administrator
- Orion Joyner, City Engineer

Prepared by: LATEEAH CHANDLER

856-757-7475

Name

Phone/Email

STATE OF NEW JERSEY
DEPARTMENT OF COMMUNITY AFFAIRS

DIVISION OF LOCAL GOVERNMENT SERVICES
GRANT APPROVAL FORM

This form must be filled out in its entirety and is intended to provide the Division with appropriate information to determine whether to approve a new or extended service. Please provide any additional information you believe will help the Division make an informed decision.

PLEASE EXPLAIN THE JUSTIFICATION FOR THE GRANT. PLEASE FULLY EXPLAIN COST ASSOCIATED WITH THE AWARD OF THE GRANT AS WELL AS ANY MATCHING FUNDS OR EMPLOYMENT OBLIGATIONS AS A TERM OF THE GRANT. PLEASE EXPLAIN THE BENEFITS OF THE GRANT OF THE MUNICIPALITY AND THE RESIDENTS. ATTACH THE GRANT APPLICATION AND GRANT AWARD LETTER.

To apply, accept and insert DCA’s 2024 Local Recreation Improvement Grant (LRIG). LRIG exists to:

- Fund improvements to recreational facilities
- Provide quality outdoor recreational space to underserved communities
- Assist local units in achieving unmet recreational obligations

If approved, the award is up to \$100,000.00 with no required match. The City intends to use the awarded funds to update community centers pools.

These improvements will allow continued service to the general public. Aquatic programs at the local swimming pool create meaningful experiences for families; opportunities for fitness goals and mental health; reduces stress for all ages; enhances public safety through our lifeguard training, water safety and swimming lessons.

Information of key municipal employee or agent applying for grant and responsible for its use:

Name	Dorri Brown
Title	Interim Director of Human Services
Telephone Number	856-757-7285
Email	dobrown@ci.camden.nj.us ; anmccoll@ci.camden.nj.us ;

If the grant is received and fully expended, what will the continuing financial obligations of the municipality be with respect to staffing, insurance, liability, operations, and/or maintenance?

Since the grant will assist in providing the funding for the rehab and not a new program or item, the City will continue to provide similar staffing, insurance, liability and operations as before the award. However, we hope that our financial obligation towards maintenance will decrease based on replacing major pool components.

What will the source of funds be for the staffing, insurance, liability, operations, and /or maintenance?

The City's 2024 Budget and future budgets is the source of funds for the staffing, insurance, liability, operations, and/or maintenance.

Mayor's Signature

Date _____

Business Administrator/Manager Signature

Date _____

Name, email and fax of contact person for this form:

For LGS use only:

Approved

Denied

Director or Designee,
Division of Local Government Services

Date _____

Number Assigned _____



Local Recreational Improvement 2024
Log #: 2024-04960-1790
Applicant: Camden City
Status: Application Submitted
Access Level: Application Administrator

Start Menu | Agency Info | RFP Menu | Application Menu

User: Ryan Talmadge Talmadge | Help | Logout

Confirmation of Application Submission

Please print a copy of this page for your records.

Mr. Ryan Talmadge Talmadge of Camden City submitted an application in response to the Local Recreational Improvement 2024 RFP on Tuesday, February 27, 2024.

DCA SAGE will send you an e-mail in the near future confirming their receipt of your application . Please note that this application will not be able to be modified in DCA SAGE until it has been reviewed by DCA SAGE. If you have any questions or concerns regarding your application, please consult your DCA SAGE representative.

Thank you for submitting this application! If you would like to continue using DCA SAGE, please [click here to return to your start menu](#). If you would like to leave DCA SAGE, please click the logout button at the top of this page.

**New Jersey Department of Community Affairs
APPLICATION FOR GRANT FUNDS**

STANDARD GRANT COVER SHEET

2024-04960-1790

1. DCA Program to Which Applicant is Applying: Local Recreational Improvement 2024			
2. Name of Applicant Agency Camden City			
3. Street Address City Hall 520 Market Street			
City Camden	State New Jersey	Zip Code 08101-5120	County Camden
4. Official Contact Person Ms. Kelly Mobley		Title Coordinator for Federal a	Phone number (856) 757-7689
5. Program Contact Person Mr. Ryan Talmadge Talmadge		Title Grant Manager	Phone Number (201) 407-8782
6. Proposed Project/Grant Title Pool Renovations Project			
Program Type Local Recreational Improvement: City of Camden			
7. Total Cost of the Project \$195,000	8. Requested Amount \$100,000	9. Funds from Other Sources \$95,000	
10. Project Location (if Different from Applicant Agency)			
Street Address 520 Market Street			
City Camden	State New Jersey	Zip 08102-1300	Room Number
11. Vendor Number 216000418-09		12. Employer ID 216000418	13. Tax Exempt ID 216000418
14. Area(s) Benefiting: City of Camden,			
15. Briefly describe the project for which you are seeking funds. To support the completion of the City of Camden's Pool Renovation Project.			

16. a. Will any member of the Board of Directors/Trustees receive any direct or indirect personal or monetary gain from the funding of this grant?

Yes No

b. Does any member of the Board of Directors/Trustees serve on any board, council commission, committee or task force which has regulatory or advising influence on the funding program? Yes No

If yes, please describe:

17. Fiscal Contact Person

Mr. Gerald C Seneski

Title

Financial Officer

Phone Number

(856) 757-7852

18. Agency Fiscal Year

7/1 to 6/30

19. Name of CPA Firm Appointed by Grantee

Bowman & Co. LLP

20. **Certification:** The applicant certifies that to the best of his/her knowledge and belief all data supplied in this application and attachments are true and correct. The document has been duly authorized by the governing body of the applicant and further understands and agrees that any grant received as a result of this application shall be subject to the grant conditions and other policies, regulation, and rules issued by the New Jersey Department of Community Affairs which include provisions described in grant applications instructions.

Name and Title of Applicant (Print)

Timothy J. Cunningham, Business Administrator

Signature of Applicant



Date of Application

2/20

OBJECTIVES

Objective Number: 1

Short Description: Renovation of the N Camden Community Center Pool

Detailed Description

Repairing the North Camden Community Center Pool will ensure this facility remains safe and fully operational for the residents of Camden City.

Methods

Renovations will include the repairing of the main drain line to resolve leaking and resurfacing of the pool shell.

Evaluation

Successful performance will be achieved once all renovations and reporting are completed on time.

Application Program Component: City of Camden

Scope of Services

The City of Camden Department of Human Services (DHS) offers a wide range of programs annually to serve the members of the community. The Department is comprised of several divisions, including the Office on Aging, Recreation, and Youth Services. Established in 1975, this office coordinates and administers a variety of counseling, social, recreational, educational, and psychological services to youth and families in the City of Camden. They coordinate the City of Camden's Municipal Drug Alliance Program, as well as the city's Multi-Agency Life Line (MALL) Program. These activities strive to connect people and resources with effective and innovative programs aimed at reducing substance abuse and juvenile delinquency in our communities. The office focuses on supporting vulnerable populations, addressing social issues, and promoting the well-being of the community.

Camden City DHS also houses the Bureau of Senior and Emergency Assistance (SEA) and the Office of Recreation. The Bureau of SEA serves and represents the needs of older residents of the City of Camden and assists those residents who experience financial hardships as a means of mitigating poverty. The Bureau's activities have included, but have not been limited to, providing scheduled senior citizen food and clothing, shopping trips, outreach to shut-in seniors, and providing seniors with leisure time activities. The Bureau also provides services to residents who are homeless, or in danger of becoming homeless. The Bureau of Recreation assists in the administration and operation of year-round comprehensive programs for residents of all ages, with a specific intent on offering recreational activities to City youth.

Within the DHS network are five community centers and two public pools, one on the north side of the city and one in the southern, downtown area known as Centerville. Public pools are only open during the summer months from 1:00PM to 5:00PM. North Camden Community Center, located at 1000 N. 6th Street, houses one of the pools with Isabel Miller Community Center, located at 8th & Carl Miller Boulevard, housing the other. The North Camden pool spans 42'x74' with a depth range of 3' to 10'. The Isabel Miller pool is configured in an "L" shape and is approximately 20' on its shortest side and approximately 40' on its longest, with a depth of 3' to 5'. Both outdoor pools are widely utilized by community members. As such, it is the goal of the Camden City DHS to be proactive in preparation for the summer months when these pools will open. Through funding from the NJ DCA LRIG program, the city will be able to make necessary renovations to its pool network, thereby making these popular sites safe for all patrons.

Local Recreational Improvement 2024
AGENCY CAPACITY

DESCRIBE YOUR AGENCY'S CAPACITY TO SUCCESSFULLY EXECUTE THE PROJECT.

Camden City, located less than two miles east of Philadelphia, is a culturally and ethnically rich 8.92 square mile city in the State of New Jersey. Camden has a population of 71,791 residents and a population density of 8,048 people per square mile, compared to the statewide average of 1,263 people per square mile. Camden has a demographic breakdown that is approximately: 42.9% Black or African American, 15.7% White alone, 7.7% two or more races, and 0.5% Asian. Of this population, 52.8% identify as Hispanic or Latino. Over 16% of Camden residents identify as foreign born, and approximately 43.9% of residents over age five speak a language other than English at home. 31.6% of residents are living below the federal poverty level, which is three times higher than the statewide rate (9.7%).

DHS understands that youth in the city are impacted by a variety of challenges. Camden, like many large cities, has historically struggled with high crime rates, including violent crimes and drug-related offenses. The presence of crime can create an unsafe environment for youth and negatively impact their well-being and development. Additionally, economic challenges, including high levels of poverty and unemployment, have been persistent issues in Camden. Growing up in economically disadvantaged households can affect the opportunities available to youth and their overall quality of life. Similarly, the city's education system has faced various challenges, including underfunding, outdated facilities, and limited access to resources. Consequently, some neighborhoods in Camden have been affected by gang activity, which can pose safety risks and potential recruitment threats to vulnerable youth. These challenges, combined with a general lack of recreational spaces and health disparities, can lead to significant physical and mental health issues.

To this end, Camden City DHS is committed to providing adequate, safe, and sustainable recreational activities to the community, particularly those under the age of 18. The City's dedication to providing a wide range of recreational opportunities for residents is evident through its programming throughout the year. By investing in its pool network, the City is continuing its longstanding mission of improving the physical and mental well-being of its residents, strengthening community bonds, fostering social connections, and supporting youth. The proposed project aims to further these objectives and expand the services offered by Camden City and DHS.

Local Recreational Improvement 2024
PROJECT DESCRIPTION

Instructions: Summarize the project description in the space below:

The City of Camden is requesting \$100,000 from the NJDCA Local Recreation Improvement Grant Program to make necessary renovations to North Camden Community Center pool, constructed between 1973 and 1977. The total project cost for repairs is \$195,000. The remaining \$95,000 will be provided through a local match. This project was identified upon completion of an engineering and conditions assessment report. This report was comprised of a full assessment of the facility's swimming pool, including structural, mechanical, plumbing, filtration, chlorination, lighting, tiles, drains, pool/deck surface, and accessibility. The report was conducted on November 2, 2023 by Brent Boyer, President of Aquatic Facility Design Inc and Pennoni Associates. During the inspection, a significant leak was discovered from the 6" deep drain. According to the report, the total cost of this replacement is anticipated to be \$120,000. Subsequently, the City will need to resurface the pool shell in order to fix the leak. This activity is estimated to cost \$75,000. Following prescriptions recommended in this report, the City of Camden will use approximately \$60,000 of the request towards the 6" deep drain line replacement and approximately \$40,000 of the request towards resurfacing the pool shell.

The project will be overseen by DHS Director Dorri Brown, with implementation to be overseen by the Project Team. The Project Team will include Director of Public Works Keith Walker, DHS Program Coordinator Janean Gooden, and Grant Manager Kelly Mobley. This team has decades of experience in municipal government, implementing recreational projects, utilizing grant funds, and the administration of grant funds. The Team will ensure the Camden City Pool Renovations Project will be completed within the 12-month timeframe, with all necessary reporting submitted to the NJ DCA.

Local Recreational Improvement 2024
PROJECT NARRATIVE

Instructions: Summarize the project narrative in the space below:

The City of Camden understands that pools play a significant role in urban communities, offering various benefits that contribute to the well-being and quality of life of residents. Pools provide residents with opportunities for recreation and leisure activities, especially during the summer months. Due to the urban environment in Camden, community members do not have easy access to natural bodies of water. This makes pools a valuable resource for avoiding heat related injuries, swimming, and socializing with their neighbors. North Camden Community Center provides such a refuge.

Swimming is an excellent form of exercise as it provides a full-body workout with low impact on joints. Having access to a pool encourages residents to engage in physical fitness activities, promoting healthier lifestyles and reducing the risk of obesity and related health issues. Camden City, like many urban communities, is a heat island, meaning surface temperatures are far hotter within the city than in surrounding suburban areas. This can lead to escalated rates of heat-related illness and death. Pools are one of the major ways in which municipalities provide residents relief from summer heatwaves. Additionally, pools offer a location for supervised swimming, which helps ensure that residents, especially children and inexperienced swimmers, have a safe environment to enjoy aquatic activities. They also provide opportunities for children and teenagers to learn essential water safety skills, develop confidence in the water, and participate in organized swim lessons and competitive swimming programs. These experiences promote personal growth, teamwork, and discipline among youth in urban communities.

North Camden Community Center is located in the largely residential neighborhood of North Camden. This neighborhood has a population of approximately 6,549, a median home value of \$78,849, and median rent of \$753 per month. Located on the corner of N 6th Street and Erie Street, the community center resides next to Camcare Health Corporation, a Federally Qualified Healthcare Center (FQHC) that has serviced Camden since 1978. Further East on Erie Street is Mastery High School, a charter school for grades 9-12, with 850 students. Along the same block as North Camden Community Center, going North on N 6th Street is Pyne Poynt Park. Pyne Poynt spans 15.2 acres and contains one baseball field, one handball wall, and two basketball courts. The Center's location to a local high school, park, and healthcare center makes it an increasingly popular destination. Repairs needed at this location cannot be overlooked as the pool serves as a valuable resource, particularly during the summer months. Funding from the NJ DCA would allow the City to maintain its commitment to providing a safe space for recreation throughout the year.

Local Recreational Improvement 2024
PROJECT STATEMENT OF NEED

Instructions: Summarize the statement of need in the space below:

Camden City experienced a decline in its manufacturing and industrial sectors throughout the 20th century, leading to significant job losses and economic stagnation. Because of these factors, the city has consistently ranked among the poorest cities in the nation. Of the over 70,000 residents, 31.6% are living below the federal poverty level, which is three times higher than the statewide rate (9.7%). Camden's public education system has faced numerous challenges, including low graduation rates and limited resources for schools serving predominantly low-income communities. A lack of quality education often perpetuates cycles of poverty by limiting opportunities for academic and economic advancement. This ties directly to the city's historically high unemployment rate of 9.3%, compared to the state unemployment rate of 4.8%.

No group of individuals are impacted more by these statistics than the city's youth. They, like their parents and grandparents, struggle with housing insecurity, including high rates of rental housing, substandard housing conditions, and homelessness which are exacerbated by limited options of affordable housing. This high level of poverty is closely linked to health disparities and as such youth are at higher rates of chronic health conditions with limited access to healthcare services and health insurance coverage. Additionally, Camden City faces two compounding factors that are correlated, that of being a heat island and having a high crime rate. With a crime rate of 44 per 1,000 residents, Camden has one of the highest crime rates in the nation compared to all communities of all sizes.

A 2021 report from the National Bureau of Economic Research followed violent crime patterns in 36 correctional facilities. Researchers discovered that days with high heat saw an increase of 18% in violence among inmates. Further, a peer reviewed article entitled "Weather and Crime: A Systematic Review of the Empirical Literature" published in 2022 found in part that violent crime correlates to the rise in temperature. Camden being an urban heat island means that residents are at a higher risk of heat-related illnesses such as heat exhaustion, heatstroke, and dehydration. Vulnerable populations, including the elderly, children, and individuals with pre-existing health conditions, are particularly susceptible to these risks. Heat islands create urban heat stress, where nighttime temperatures remain elevated, providing little relief from the heat. This prolonged exposure to high temperatures can disrupt sleep patterns, increase stress levels, and negatively impact mental health and overall well-being.

While the Camden City Pool Renovations Project does not claim to resolve all facets of high crime or the city being a heat island, ensuring its pool network is open and operational during the summer months will undoubtedly have a positive impact on residents in the area. The completion of this project will effectively double the options residents have to avoid heat related injuries, lower body temperature, and lower their overall stress levels. It also gives young people refuge from more dangerous environments and circumstances that they may otherwise find themselves in if spaces like the North Camden Community pool are not open.

Local Recreational Improvement 2024
PROJECT SCHEDULE AND WORK PLAN

Instructions: Summarize the project schedule and work plan in the space below:

The Camden City Pool Renovations Project will be completed within the 12-month project period. It is anticipated to begin in June 2024, with all construction and reporting to be completed by May 2025. Below is a timeline of project deliverables, given awards are issued in the Spring of this year.

- Grant Awarded - Month 0
- Bidding Documents Prepared and Released - Month 1
- Design Start - Month 2
- Design Completed - Month 4
- Construction Start - Month 6
- Construction Completed - Month 12

This project benefits the community by encouraging an active, healthy lifestyle and providing opportunities through investing in much needed repairs to the North Camden Community Center pool. The City is confident that this project will have an immediate benefit to community members in the area, especially young people in need of refuge during the summer months.

Local Recreational Improvement 2024
OTHER SOURCES OF FUNDING RELATED TO THIS APPLICATION

<u>Source</u>	<u>Amount</u>	<u>Code</u>
City of Camden	\$95,000.00	(L)

Total Funds From Other Sources Related To This Application Only \$95,000.00

Local Recreational Improvement 2024

CERTIFICATION SHEETS

<i>If your Agency type is not required to answer any of the questions below, click the N/A radio button</i>			
1.	I certify that this agency is not delinquent on any Federal or State debt.	<input checked="" type="checkbox"/> Yes	<input type="checkbox"/> No <input type="checkbox"/> N/A
2.	I understand that payments from NJDCA will depend on our submission of all required grant reports.	<input checked="" type="checkbox"/> Yes	<input type="checkbox"/> No <input type="checkbox"/> N/A
3.	I certify that neither members of our organization's governing body nor members of their families will receive any direct or indirect personal or monetary gain from the funding of this grant.	<input checked="" type="checkbox"/> Yes	<input type="checkbox"/> No <input type="checkbox"/> N/A
4.	I certify that our organization's Certification of System for Award Management(SAM) is valid and current.	<input checked="" type="checkbox"/> Yes	<input type="checkbox"/> No <input type="checkbox"/> N/A
5.	I certify that neither members of our organization's governing body nor members of their families serve on any board, council, commission, committee, or task force that has regulatory authority or advising influence on the funding program.	<input checked="" type="checkbox"/> Yes	<input type="checkbox"/> No <input type="checkbox"/> N/A
	If no, please explain:		
Non-government Agencies only—			
6.	If our agency has not received funds from NJDCA for the current State Fiscal Year, I will submit our organization's most recent audit.	<input type="checkbox"/> Yes	<input type="checkbox"/> No <input checked="" type="checkbox"/> N/A
7.	The information contained in the Board of Directors list in our Agency Information is adequate and up-to-date at the time of this application.	<input type="checkbox"/> Yes	<input type="checkbox"/> No <input checked="" type="checkbox"/> N/A

Local Recreational Improvement 2024

CERTIFICATION SHEETS

ATTACHMENTS	
Certification Regarding Debarment and Suspension - Schedule G	
I will upload this attachment <input checked="" type="checkbox"/>	Not applicable <input type="checkbox"/> 437221-314711-schedule g - fy24 lrig - camden city.pdf
Certification Regarding Lobbying - Schedule H	
I will upload this attachment <input checked="" type="checkbox"/>	Not applicable <input type="checkbox"/> 437221-314713-schedule h - fy24 lrig - camden city.pdf
Resolution - Schedule I Or Local Match Only - Schedule I	
I will upload this attachment <input checked="" type="checkbox"/>	Not applicable <input type="checkbox"/> 437221-314715-fy24 njdca - resolution draft - city of
IRS Determination Letter (New Applicants, Non-profit, Non-government only)	
I will upload this attachment <input type="checkbox"/>	Not applicable <input checked="" type="checkbox"/>
Organizational Chart (Non-government only)	
I will upload this attachment <input type="checkbox"/>	Not applicable <input checked="" type="checkbox"/>
Application Cover Page	
I will upload this attachment <input checked="" type="checkbox"/>	Not applicable <input type="checkbox"/> 437221-314717-application cover form - fy24 njdca
Please upload any third party agreement(s) that may be pertinent to this grant. (see application instructions for specific details)	
437221-314696-north camden community center pool assessment report rev 1.18.24. w appendix.pdf	

**CITY OF CAMDEN
RESOLUTION**

*signed resolution will be forwarded after the next City Council Meeting as per DCA instruction

Whereas, the City of Camden desires to apply for and obtain a grant from the New Jersey Department of Community Affairs for approximately \$100,000.00 to carry out its Pool Renovation Project.

Be it therefore RESOLVED,

- 1) that the **Mayor and City Council** does hereby authorize the application for such a grant; and,
- 2) recognizes and accepts that the Department may offer a lesser or greater amount and therefore, upon receipt of the grant agreement from the New Jersey Department of Community Affairs, does further authorize the execution of any such grant agreement; and also, upon receipt of the fully executed agreement from the Department, does further authorize the expenditure of funds pursuant to the terms of the agreement between **City of Camden** and the New Jersey Department of Community Affairs;

Be it further RESOLVED, that the persons whose names, titles, and signatures appear below are authorized to sign the application, and that they or their successors in said titles are authorized to sign the agreement and any other documents necessary in connection therewith:

_____ (signature)	_____ (signature)
_____ Victor G Carstarphen (type or print name)	_____ Timothy J Cunningham (type or print name)
_____ Mayor (title)	_____ Business Administrator (title)

CERTIFICATION:

I, Luis Pastoriza, the Clerk of the City of Camden hereby certify that at a meeting of the Council of the City of Camden held on March 12, 2024, the above *RESOLUTION* was duly adopted.

AFFIX GOV'T,
CORPORATE OR
NOTARY SEAL

(Signature of Secretary of the City Council or City Clerk)

New Jersey Department of Community Affairs
APPLICATION FOR GRANT FUNDS

CERTIFICATION REGARDING DEBARMENT AND SUSPENSION

In accordance to Federal Executive Order 12549, "Debarment and Suspension," the undersigned certifies, to the best of his or her knowledge that as an applicant, this agency or its key employees:

- a. are not presently debarred, suspended, proposed for debarment, declared ineligible, or voluntarily excluded from covered transaction by any Federal Department or agency, or by the State of New Jersey;
- b. have not within a 3-year period preceding this application been convicted of or had a civil judgment rendered against them for commission of fraud or a criminal offense, in connection with obtaining, attempting to obtain, or performing a public (Federal, State, or Local) transaction or contract under a public transportation; violation of Federal or State antitrust statutes or commission of embezzlement, theft, forgery, bribery, falsification or destruction of records, making false statements, or receiving stolen property.
- c. are not presently indicted or for otherwise criminally or civilly charged by a governmental entity (Federal, State, or Local) with commission of any offenses enumerated in paragraph (b) of this certification; and
- d. have not within 3-year period preceding this application had one or more public transactions (Federal, State, or Local) terminated for cause or default.

The applicant agrees that by submitting this application, it will obtain from all its subgrantees a certification that includes without modification paragraphs (a), (b), (c), (d), of this certification in accordance with Federal Executive Order 12549.

NAME OF AGENCY City of Camden	
NAME AND TITLE OF OFFICIAL SIGNING FOR AGENCY Timothy J. Cunningham, Business Administrator	
SIGNATURE OF ABOVE OFFICIAL 	DATE SIGNED 2/20
<p>NOTE: The following document related to Debarment and Suspension as required by Federal regulations will be used as the basis for completion of this certification:</p> <p>List of <i>parties excluded</i> from Federal Procurement or Non-Procurement Programs. This document is distributed by U.S. General Services Administration, U.S. Printing Office, Washington, D.C. This document can be acquired from the Superintendent of Documents by calling (202) 783-3238.</p>	

New Jersey Department of Community Affairs
APPLICATION FOR GRANT FUNDS

CERTIFICATION REGARDING LOBBYING

The undersigned certifies, to the best of his or her knowledge that:

- a. No grant funds awarded from State and/or Federal appropriations have been paid or will be paid, by or on behalf of the grantee, to any person for influencing or attempting to influence an officer or employee of any agency, a Member of Congress, an officer or employee of Congress, or an employee of a Member of Congress in connection with the making of any grant, the making of any loan, the entering into of any cooperative agreement, and the extension, continuation, renewal, amendment, or modification of any grant, loan, or cooperative agreement.
- b. If any funds other than Federal appropriated funds have been paid or will be paid to any person for influencing or attempting to influence an officer or employee of any agency, a Member of Congress, an officer or employee of Congress, or an employee of a Member of Congress in connection with this, grant, loan, or cooperative agreement, the grantee shall complete and submit the Standard Form-LLL, "Disclosure Form to Report Lobbying," in accordance with its instructions. This form can be found at the following website address: <http://www.hhs.gov/oagam/oam/opportunities/rfp0202/sf111.pdf>.
- c. The grantee shall require that the language of this compliance requirement (certification) be included in the award documents for all subawards at all tiers (including subcontracts, subgrants, and contracts under grants, loans, and cooperative agreements) and that all subrecipients shall certify and disclose accordingly.

This requirement (certification) is a material representation of fact upon which reliance was placed when this transaction was made or entered into. Submission of this certification is a prerequisite for making or entering into this transaction imposed by Section 1352, Title 31, U.S. Code. Any person who fails to file the required certification shall be subject to a civil penalty of not less than \$10,000 and not more than \$100,000 for each such failure.

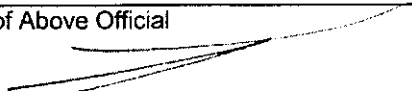
Name of Agency City of Camden	
Name and Title of Official Signing for Agency Timothy J. Cunningham, Business Administrator	
Signature of Above Official 	Date Signed 2/20

January 18, 2024

COCMX 23007

Stephanie Walker
Division of Capital Improvements & Project Management
City of Camden
520 Market Street, Suite 325
Camden, NJ 08102

**RE: NORTH CAMDEN COMMUNITY CENTER POOL
1000 N. 6TH STREET, CAMDEN, NEW JERSEY
ENGINEERING / CONDITION ASSESSMENTS**

Dear Ms. Walker,

In accordance with our October 2, 2023 proposal, Pennoni Associates Inc. ("Pennoni") has completed an engineering and condition assessment of the North Camden Community Center Pool (the Site) for the City of Camden (the City). The Site is located at the northeast corner of the intersection of Erie Street and N. 6th Street. The Site is further identified as Tax Block No. 747, Lot 1.

The Scope of Services for our work was in accordance with City's Request for Proposal, and the subsequent email from your office dated September 28, 2023, which revised the sought-after services. Details of study methodology and the findings of the assessment are presented below.

1.0 Scope of Work

During the project, the project team conducted the following tasks:

- Pennoni collected and reviewed available information including aerial photos, maps and other information. No plans of the site were available for review.
- The project team conducted an assessment of the swimming pool and associated equipment/systems including but not limited to structural, mechanical, plumbing, filtration, chlorination, lighting, tiles, drains, pool deck/surface, access, and any other inspection necessary for compliance with state and local code requirements.
- The project team reviewed the current condition of the existing pool for compliance with ADA and other applicable safety regulations.
- Pennoni compiled the findings of our investigation into this assessment report.

The project team consisted of Mr. Brent Boyer, President of Aquatic Facility Design, Inc. (Pool Condition assessment), Mr. Bob Mellohusky, P.E. of Pennoni (Mechanical, Electrical and Plumbing systems assessment) and Mr. Jim Mullan, P.E. of Pennoni (Project Manager).

The project team visited the Site on November 2, 2023, to conduct the inspection and conduct interviews with City personnel.

2.0 Review of Historical Data

Review of historical records indicate the pool was constructed between 1973 and 1977. Historical information and records are included in Appendix A.

3.0 Findings – Site Inspection and Interviews

A summary of the assessment follows below:

Pool Shell, Layout and Access

- The subject pool was constructed in a rectangular configuration, measuring approximately 42'x74', with a depth ranging from 3 feet to 10 feet. No testing was performed on the pool shell, but all indications are that it is sound and in stable condition.
- The materials of construction of the subject pool are concrete with two layers of marcite plaster applied as a finish. The pool plaster finish is generally in stable condition, however, some smaller areas are coming loose particularly on the walls. In these areas the finish is becoming somewhat abrasive and in need of repair or renovation.



Figure 1 – Area of plaster in a state of disrepair

- The tile and coping pool top are in good to very good condition.
- During the inspection skimmers were observed around the perimeter of the pool. Individual inspection of each of these revealed that one of the skimmers has a cracked housing and is need of repair or replacement.
- The base pool design does not include provisions for complying with relevant American with Disability Act (ADA) requirements. Specifically, the subject pool has a “step in” design with two sets of non-ADA stairs and a series of ladders.



Figure 2 – Subject Pool

Pool Recirculation System

- The recirculation system consists of side wall skimmers, side wall filtered water returns and side wall return system for filtered water distribution, and a direct link dual main drain system with Virginia Graeme Baker grates (VGB) (the drain piping size could not be confirmed in either of the two drain boxes).
- A single tank sand system with a pump and motor are located on the floor slab in the Filter Building to recirculate the pool. There is a liquid chlorine and CO2 system for sanitation. The CO2 system and chlorine injection pump appear to be in fair to good operating condition.
- Inspection of the skimmer line indicated the presence of water and a return plug was out, indicating that the system was not properly winterized. City personnel were informed of this observation at the time of the site inspection.
- Field observations and discussions with maintenance personnel suggests that there is a significant

leak from the 6" deep drain.



Figure 3 – Subject Pool Shell (Empty due to suspected leak in deep drain line)

Amenities

- No play features or water play features exist.

Mechanical, Plumbing and Electrical

The mechanical and plumbing systems were assessed for operability, code compliance, and the overall existing conditions were recorded. Pool operations were discussed with maintenance staff and issues were noted for any operational concerns due to the timing of the site visit (pool was not in operation). The findings are listed below.

- Main Pump and Filter – Currently there are no issues with respect to this equipment. Inquiries to City personnel indicated that the filter pump motor had failed less than a year after installation last season. A reason for the motor failure could not be determined.
- The pool uses chlorine for sanitation and CO₂ for pH adjustment. Both the Chlorine injection pump and the CO₂ system were observed to be in good condition.
- Both electrical service and potable water service (for pool supply purposes) originate from the main building on the Site.
- Moderate to severe corrosion was observed on the electrical panel, circuit breakers, and power distribution components – conduits, receptacles, switches, etc.



Figure 4 – Electrical Panel with Corrosion and in a State of Disrepair –
Note efflorescence or chemical staining on walls

- Site lighting is provided from pole mounted, dual-headed fixtures and a wall mounted fixture on the main building. Lighting within the pool filter building is provided via surface mount interior fixtures attached to the ceiling. The interior lighting was observed to be in fair condition.
- The pool make-up water valve, outdoor showers and drinking water fountain require maintenance and repair.

Pool Filter Building

- The building is approximately 10'x35' and is constructed slab on grade. Materials of construction consist of masonry block, steel framing and a flat, poured concrete roof.
- Damage was observed to the exterior wall in the northeast corner of the building. Further, some minor cracking was observed in the mortar joints along the building facades. Moderate paint peeling and cracking was observed on the exterior walls.
- Interior pipe and electrical conduit supports were observed to be severely corroded.
- The building is provided with natural ventilation – (2) 3' x 3' (approx.) louvers located in opposite end walls. Louver bird/insect screens are in a sever state of disrepair.
- No visible evidence of leaking of roof, walls, or slab perimeter.
- There is no potable water service in the building.
- Interior lighting provided via switch controlled ceiling mounted fluorescent fixtures.



Figure 5 – Pool Filter Building exterior



Figure 5 – Pool Filter Building exterior

4.0 Recommendations

Based upon this assessment, the following actions regarding the subject pool are warranted:

- The leak in the pool is severe. Based upon our observations and inquiries to City personnel, it is suspected that the source of the leak is a broken deep 6"-diameter main drain line. The main drain line should be pressure tested to confirm or repudiate this suspicion. Whether the 6" line extends into each drain box should also be confirmed as well as the flow rating on the two drain covers.

If pressure testing confirms the source of the leak as the main drain line, the cost to repair such a leak would be expected to be between \$60,000 and \$120,000.

- The subject pool is not in compliance with current ADA accessibility requirements. Based upon its size (less than 300 ft perimeter), the subject pool should have one accessible means of entry, provided that it is either a pool lift or a sloped entry. The cost to provide such accessibility is expected to be between \$8,000 and \$12,000.
- The pool plaster finish is in fair to good condition, however, some smaller areas are coming loose and the finish is becoming abrasive, particularly on the walls and needs to be repaired. It is recommended that the loose areas of plaster be removed and repaired and the finish be coated with a rubber-based paint. The cost to perform the surface repair and apply three (3) coats of paint (to the entire pool interior) will be expected to be between \$30,000 and \$50,000.
- A skimmer with a cracked housing was observed during the site inspection. The cost to replace this equipment and conduct restoration activities in the surround concrete pool deck is expected to be between \$5,000 and \$7,000.
- Recommended actions with respect to the Pool Filter Building include the following:
 - Repairing damaged exterior walls and cracking.
 - Replacing/installing the louver bird screenings (with corrosion resistant materials).
 - Painting interior and exterior walls.
 - Replace corroded pipe and conduit supports (with corrosion resistant materials).
 - Install exterior wall-mounted LED light fixture above door. With dusk-to-dawn or timer controls.
 - Based on its use, the building's space should be provided with an exhaust fan that can provide two to six air changes per hour. The fan should be equipped with an automatic timer control.
 - Moderate to severe corrosion was observed on the electrical panel, circuit breakers and other electrical equipment in the Pool Filter Building. Pennoni recommends replacement of the entire electrical service in the building.

The cost to conduct the recommended repairs for the Pool Filter Building is expected to be between \$60,000 and \$80,000.

- The pool make-up water valve, outdoor showers and drinking water fountain require minor maintenance and repair. The cost to perform this work is expected to be between \$1,000 and \$2,000.
- Muriatic acid was noted to be stored inside the Pool Filter Building. The presence of the acid can

cause corrosion to building materials and equipment. It is recommended that the acid not be stored in the Pool Filter Building during the off season. The cost to affect this recommendation is expected to be negligible.

The above recommendations do not account for the lack of amenities at the facility. Water play attractions such as slides, climbing walls, diving boards, water sprays, floatable features, beach entries with water features, etc., are features which can enhance the recreational experience for the pool's patrons. Additionally, the Site does not have a wading pool or similar that can be dedicated to small children – allowing a safer recreational opportunity for them.

The cost of adding features can vary greatly depending on what is chosen but a range of \$100,000 to \$250,000 for the facility is not unusual. The cost of adding a separate wading pool or splash pad if space permits is estimated at \$650,000.

5.0 Summary

The total cost of undertaking the recommended actions is anticipated to be between \$160,000 and \$270,000.

The project team is available to discuss the findings and recommendations of this assessment upon request.

Please feel free to contact us with any questions.

Sincerely,

PENNONI ASSOCIATES INC.

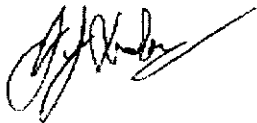

Joseph J. Raday, PE, CME
Associate Vice President



James Mullan, PE
Project Manager

APPENDIX A

North Camden Community Center - 2020 Aerial



1/12/2024, 3:03:18 PM

-  Override 1
-  Municipalities
-  County Boundaries
-  Parcels Data (Block and Lot)

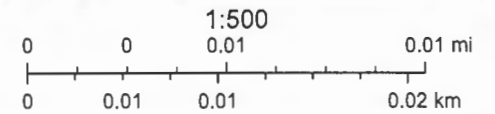

Esri Community Maps Contributors, City of Philadelphia, data.pa.gov, New Jersey Office of GIS, © OpenStreetMap, Microsoft, Esri, TomTom, Garmin.

New Jersey Department of Environmental Protection

North Camden Community Center - 2012 Aerial



1/12/2024, 3:01:57 PM

-  Override 1
-  Municipalities
-  County Boundaries
-  Parcels Data (Block and Lot)

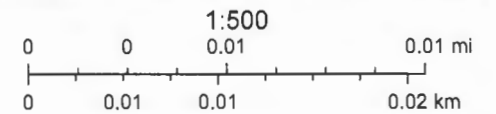

Esri Community Maps Contributors, City of Philadelphia, data.pa.gov, New Jersey Office of GIS, © OpenStreetMap, Microsoft, Esri, TomTom, Garmin,

New Jersey Department of Environmental Protection

North Camden Community Center - 2002 Aerial



1/12/2024, 3:05:24 PM

-  Override 1
-  Municipalities
-  County Boundaries
-  Parcels Data (Block and Lot)

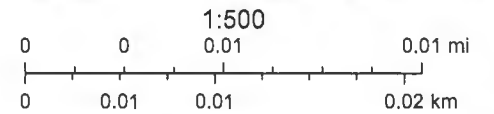

Esri Community Maps Contributors, City of Philadelphia, data.pa.gov, New Jersey Office of GIS, © OpenStreetMap, Microsoft, Esri, TomTom, Garmin,

New Jersey Department of Environmental Protection

North Camden Community Center - 1995 Aerial



1/12/2024, 3:09:37 PM

- Override 1
- Municipalities
- County Boundaries
- Parcels Data (Block and Lot)

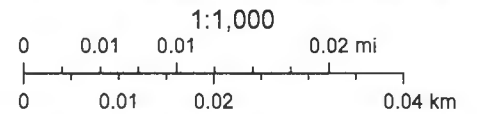

Esri Community Maps Contributors, City of Philadelphia, data.pa.gov, New Jersey Office of GIS, © OpenStreetMap, Microsoft, Esri, TomTom, Garmin,

New Jersey Department of Environmental Protection

North Camden Community Center - 1977 Aerial

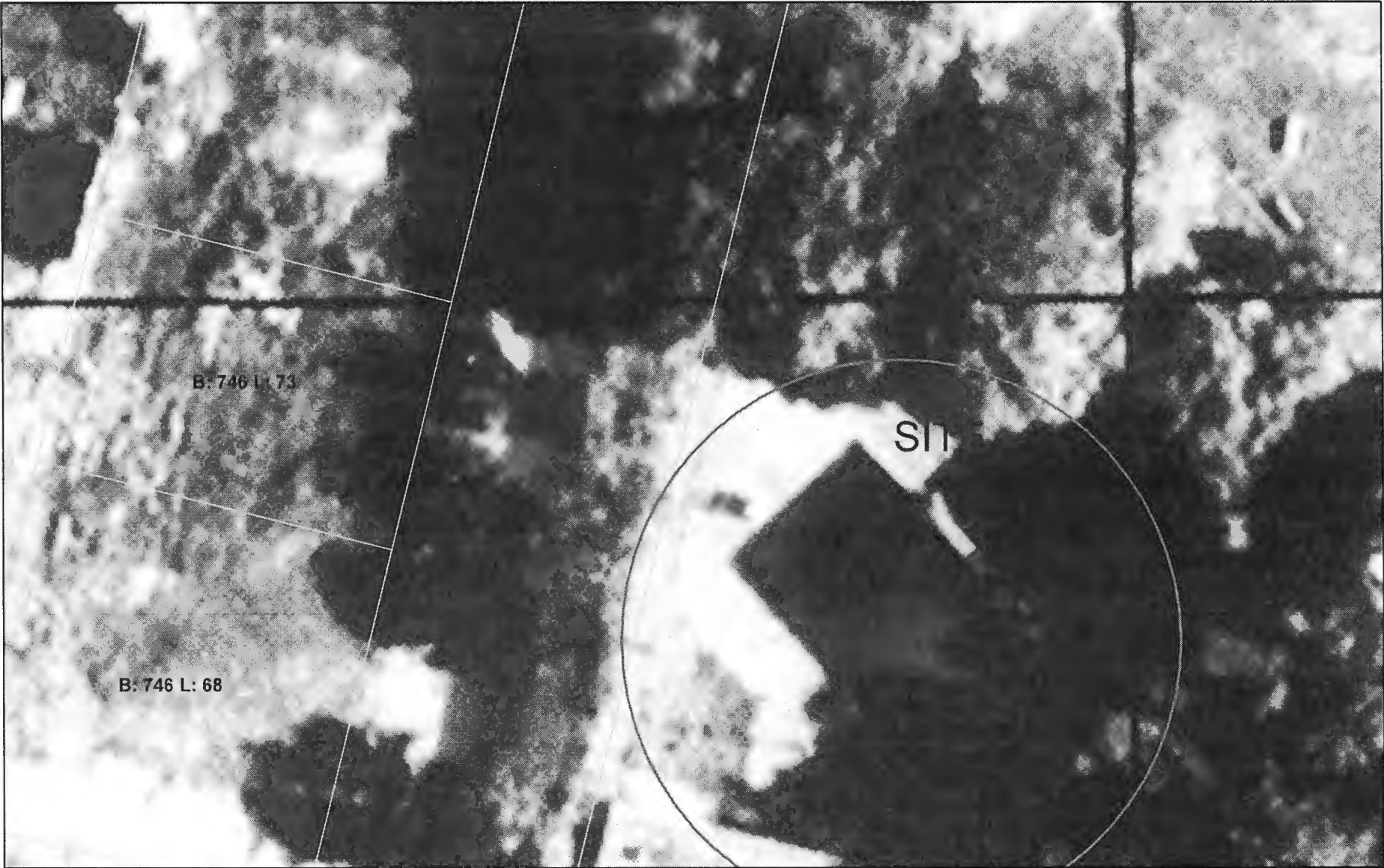

1/12/2024, 3:06:59 PM

-  Override 1
-  Municipalities
-  County Boundaries
-  Parcels Data (Block and Lot)

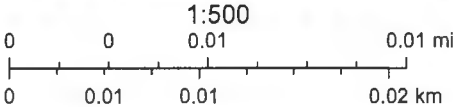



Esri Community Maps Contributors, City of Philadelphia, data.pa.gov, New Jersey Office of GIS, © OpenStreetMap, Microsoft, Esri, TomTom, Garmin,

New Jersey Department of Environmental Protection

Isabel Miller Community Center - 1970 Aerial



1/12/2024, 3:25:00 PM

-  Override 1
-  Municipalities
-  County Boundaries

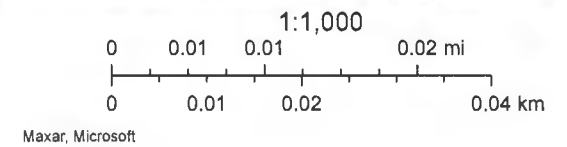

Owner Information

Name Camden City
Street Po Box 95120
City&State Camden, NJ
Zip 08101

Property information

Last Updated 06/15/2020
Municipality Camden City
Block 747
Lot 1
Qualifier
Property Location 1000 No 6Th St
Property Class Code 15C
Building Description B'S
Year Built 0
Building SqFt. 0
Land Description 15.2AC M010
Acreage 15
Additional Lots 1
Additional Lots 2 COMM CENTER,GYM

Sale Information

Date
Deed Book
Deed Page
Price \$0
Assessment \$0
Property Use Code 611
SR1A NU Code

Sales History

Date	Price	Assessment
------	-------	------------

Assessment History

Year	Class	Land Value	Improvement	Net
2024	15C	\$1,328,200	\$1,409,000	\$2,737,200
2023	15C	\$1,328,200	\$1,409,000	\$2,737,200
2022	15C	\$1,328,200	\$1,409,000	\$2,737,200
2021	15C	\$1,328,200	\$1,409,000	\$2,737,200

Exempt Property Information

EPL_Code 0401613
Facility COMMUNITY CENTER
Initial Filing Date
Further Filing Date
Exempt Statute 54:4-3.3

Map Page
Zoning
Old Block 00011
Old Lot 00001
Old Qualifier
Land Value \$1,328,200
Improvement Value \$1,409,000
Exemption Amount #1
Exemption Amount #2
Exemption Amount #3
Exemption Amount #4
Net Tax Value \$2,737,200



EQ SERIES®

HIGH PERFORMANCE COMMERCIAL PUMP

FOR COMMERCIAL SWIMMING POOLS AND OTHER WATER APPLICATIONS

EQ Series Pumps are designed for maximum efficiency and quiet operation in every detail. They are the only non-corrosive, all-plastic pumps designed for the commercial pool and water applications market. The EQ Series Pump impellers are manufactured for true breakthrough performance, allowing for lower loads and longer motor life. The pumps are available with and without the strainer pot and in flows to 800 GPM and from 3-15 HP.

STANDARD FEATURES

- Close-coupled for quiet, stable flow operation.
- Lightweight for easy, one-man installation.
- Clear Cam and Ramp™ Lid for added service convenience.
- Available in single- and three-phase models. TEFC motor available three-phase only.
- Closed impeller for long life and durability.
- 6" suction and 4" discharge with strainer pot.
- Great for use with Acu Drive™ XS Variable Frequency Drives.
- Self-priming under NSF standards; NSF Certified.

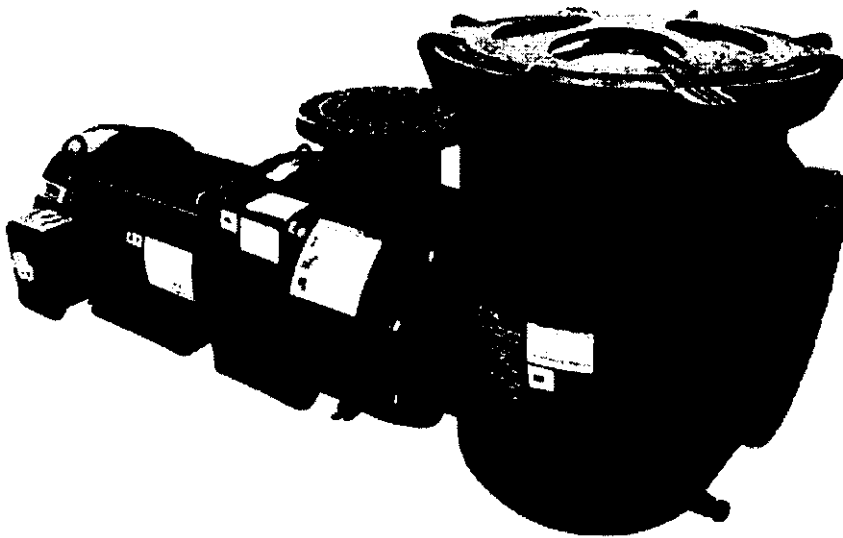

EQ Series Commercial Pump Performance Curve

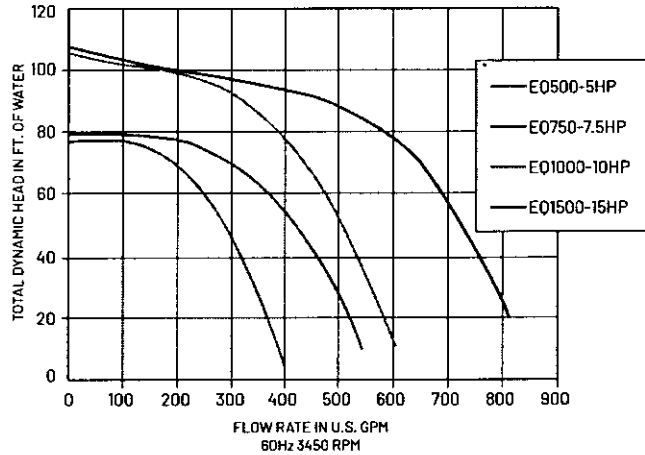

EQ Series WaterFall Pump Performance Curve

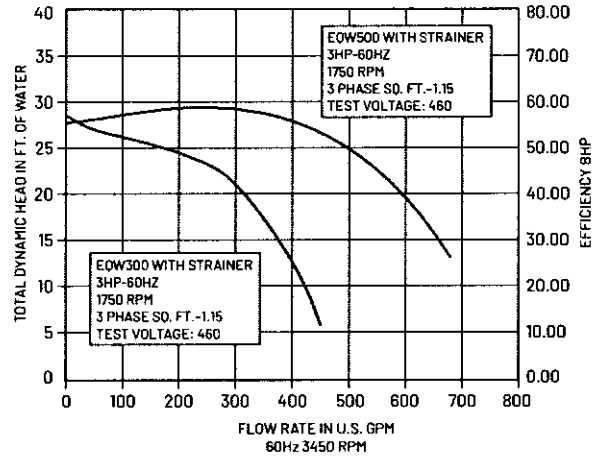

MATERIALS AND DESIGN

PUMP BODY

Volute type, back pull-out design.

- Port Size
 - 6" - ANSI Rated 125 bolted flange suction port¹.
 - 4" - ANSI Rated 125 bolted flange discharge port¹.
- Material - Volute & Motor Adapter
 - PPO Resin
- Impeller
 - PPO Resin
- Base
 - 6061 aluminum design, slotted for mounting ease.
- Corrosion Prevention
 - All-plastic pump for maximum hydraulic performance and corrosion prevention.

HAIR AND LINT STRAINER

- Material
 - Separate bolt-on PPO Resin body with plastic basket, Polycarbonate Resin Thermoplastic lid, and stainless steel bolts.
- Size
 - 6" ANSI Rated 125 bolted flange suction and discharge ports.

PUMP MAXIMUM THERMAL LIMITS

- Ambient air temperature: 104° F
- Liquid temperature: 104° F

MOTOR

Standard JM type. Premium Efficient ODP Class F insulated. On TEFC options, JMZ type, Premium Efficient, Class F insulated.

- Frame and Size
 - NEMA Rated "C" flange.
- Shaft
 - 303 stainless steel construction.
- Design
 - 3 to 15 HP, 3500 RPM, JM open drip-proof, continuous duty, three-phase and single-phase (5, 7-1/2, 10 HP). 5 to 15 HP, 3500 RPM JMZ TEFC, continuous duty three-phase.
- Bearings
 - Double-shielded, single row, deep-groove type, permanently lubricated.
- Thermal Overload Protection
 - All models require external thermal overload protector.

ELECTRICAL

- Power Supply Required
 - Three-phase pumps are 208-230/460. Single-phase models are available in ODP 230v, 60 Hz only.

¹Use ANSI Rated class 125 plastic flange and 1/8" thick class 125 full flange gasket to make connection.

EQ Series Commercial Pump with Strainer Pot 6" x 4"

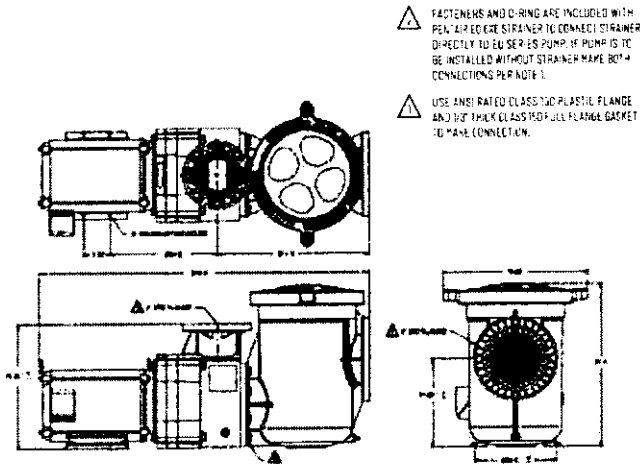

FASTENERS AND O-RING ARE INCLUDED WITH PENTAIR EQUESTER STRAINER TO CONNECT STRAINER DIRECTLY TO EQ SERIES PUMP. IF PUMP IS TO BE INSTALLED WITHOUT STRAINER MAKE BOTH CONNECTIONS PER NOTE 1.

USE ANNEALED CLASS 150 PLASTIC FLANGE AND 1/4" THICK CLASS 150 FULL FLANGE GASKET TO MAKE CONNECTION.

EQ Series Commercial Pump without Strainer Pot

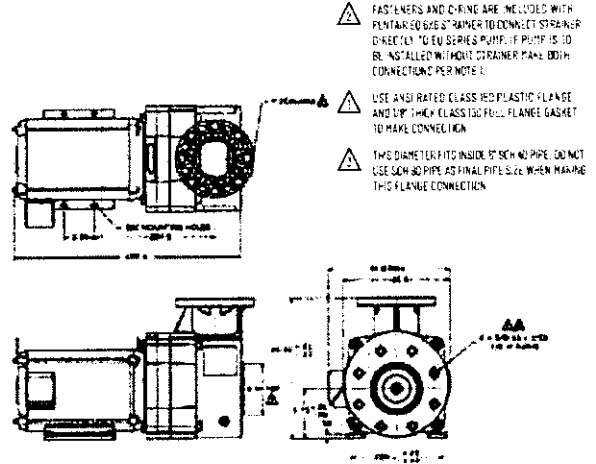

FASTENERS AND O-RING ARE INCLUDED WITH PENTAIR EQUESTER STRAINER TO CONNECT STRAINER DIRECTLY TO EQ SERIES PUMP. IF PUMP IS TO BE INSTALLED WITHOUT STRAINER MAKE BOTH CONNECTIONS PER NOTE 1.

USE ANNEALED CLASS 150 PLASTIC FLANGE AND 1/4" THICK CLASS 150 FULL FLANGE GASKET TO MAKE CONNECTION.

THIS DIAMETER FITS INSIDE OF SCH 40 PIPE. DO NOT USE SCH 40 PIPE AS FINAL PIPE SIZE WHEN MAKING THIS FLANGE CONNECTION.

EQ SERIES COMMERCIAL PUMP WITH STRAINER POT 6" X 4"

Part # ODP Motor	Part # TEFC Motor	Description (ODP Motor/ TEFC Motor)	Voltage	Amps	Phase	HP	Wt	Dim. A-ODP	Dim. A-TEFC	Dim. B	Dim. C	Dim. D-ODP	Dim. D-TEFC
340026	—	EOW 300 WaterFall	208/230	38/19	1	3	126	26.62	N/A	10.03	7.5	43.590	N/A
340027	—	EQWK 300 WaterFall	208-230/460	8.4-7.9/3.9	3	3	106	23.12	N/A	10.16	7.5	40.094	N/A
340028	—	EOW 500 WaterFall	230	23.4	1	5	126	26.62	N/A	13.18	9.7	43.590	N/A
340029	—	EQWK 500 WaterFall	208-230/460	13.6-12.7/6.4	3	5	106	23.12	24.68	13.31	9.7	40.094	41.65
340030	—	EQ500	230	19.6	1	5	126	26.62	N/A	10.03	7.5	43.590	N/A
340031	340604	EQK500/EQKT500	208-230/460	13.5-12.3/6.2	3	5	106	23.12	24.68	10.16	7.5	40.094	41.65
340032	—	EQ750	230	30.4	1	7.5	161	27.53	N/A	10.78	8.5	44.590	N/A
340033	340605	EQK750/EQKT750	208-230/460	20.1-18.3/9.1	3	7.5	116	24.50	28.06	10.16	7.5	41.560	45.12
340034	340606	EQK1000/EQKT1000	208-230/460	27.1-24.3/12.2	3	10	146	26.31	29.81	10.78	8.5	43.290	46.79
340035	340607	EQK1500/EQKT1500	208-230/460	40.0-36.0/17.8	3	15	161	26.31	28.31	10.78	8.5	43.290	45.29
340238	—	EQ1000	230	40.0	1	10	179	29.0	N/A	11.50	8.5	46.29	N/A

340013 Strainer Pot Assembly including Strainer, Lid, Basket and Hardware

EQ SERIES COMMERCIAL PUMP WITHOUT STRAINER POT 6" X 6"

Part # ODP Motor	Part # TEFC Motor	Description	Voltage	Amps	Phase	HP	Wt
340014	—	EOW 300 WaterFall	115/230	38/19	1	3	97
340016	—	EQWK 300 WaterFall	208-230/460	8.4-7.9/3.9	3	3	77
340017	—	EOW 500 WaterFall	230	23.4	1	5	97
340018	—	EQWK 500 WaterFall	208-230/460	13.6-12.7/6.4	3	5	77
340019	—	EQ500	230	19.6	1	5	97
340020	340608	EQK500/EQKT500	208-230/460	13.5-12.3/6.2	3	5	77
340021	—	EQ750	230	30.4	1	7.5	132
340022	340609	EQK750/EQKT750	208-230/460	20.1-18.3/9.1	3	7.5	87
340237	—	EQ1000	230	40.0	1	10	125
340023	340610	EQK1000/EQKT1000	208-230/460	27.1-24.3/12.2	3	10	117
340024	340611	EQK1500/EQKT1500	208-230/460	40.0-36.0/17.8	3	15	132

EQ Series pumps are available in 575V and 50 Hz models. Please contact your local sales representative or Pentair office for details.

EQ SERIES®

HIGH PERFORMANCE COMMERCIAL PUMP



ENGINEERING SPECIFICATIONS

EQ Series Pump

- Recirculation pump shall be Pentair® EQ Series pump Model No. _____ self-priming centrifugal pump, ____ phase, 60 Hz.

General Notes

- Install pump in a cool, dry, well-vented location away from pool heaters and chemical storage.
- Pump should be firmly mounted with pipe supported to prevent vibration and undue operational noise.
- Allow 12" minimum clearance behind motor for servicing.
- Motor overheating may be caused by a voltage drop or excessive voltage. Be sure that wire size and voltage input are properly regulated.

Specifications

- The recirculation pump shall be a self-priming, centrifugal design with a hair and lint strainer as shown in the plans.
- The pump body, seal plate, and attached hair and lint strainer shall be constructed of non-corrosive PPO resin materials and close-coupled to an electric motor by means of an adaptor of the same material. The pump body shall have a single suction port with a 6" ANSI Rated 150 bolt flange to the hair and lint strainer. A centerline discharge port of 4" ANSI Rated 150 bolt flange and a winterizing drain port of 1/4" NPT shall be a part of the design.
- The pump shall be a back pull-out design to allow servicing without disturbing piping. The pump shall have a PPO resin diffuser to aid in priming and it shall contain a replaceable bronze wear ring for the impeller. The impeller shall be of the closed type and PPO resin, non-overloading at any point on the performance curve. The mechanical shaft seal shall be constructed of ceramic and carbon seal faces, with stainless steel and Buna N materials in the spring bellows portion. The impeller shall be secured to the motor shaft by means of a stainless steel key and locking screw into the end of the motor shaft. The pump shall be capable of operating at up to 50 PSI, 104° F continuous water temperature.

- The electric motor coupled to the pump shall be of the NEMA Rated series JM construction with stainless steel shaft inside a removable shaft sleeve of 303 series stainless steel. The motor shall be of an open, drip-proof design (or TEFC JMZ frame) with double-shielded, single row, deep-groove ball bearings. Motors shall be continuous-duty rated at 40° C (or align better) ambient and be suitable for outdoor installation.
- The pump motor shall be a ____ HP, ____ phase, 60 Hz, 3450 RPM for service on a ____ volt electric supply. The pump shall be rated for _____ GPM at ____ TDH. The pump shall be tested and certified by a nationally recognized testing laboratory to conform to National Sanitation Foundation Standard 50.

Hair and Lint Strainer

- The pump strainer shall consist of a PPO resin body, polycarbonate resin thermoplastic cover with O-ring seal, and Cam and Ramp™ lid, and a strainer basket of mineral-reinforced polypropylene material.
- The strainer body shall be 6" ANSI Rated 150 bolt flanged suction and discharge ports. The strainer body shall have a removable drain plug for winterizing.
- The strainer basket shall be securely positioned below the suction inlet of the trap, with access for inspection and cleaning through a removable trap body lid. The trap body lid shall be secured by means of a locking ring. The strainer basket shall have a perforation which in total open area is 98 square inches.



400 Regency Forest Dr | Cary, NC 27518 | United States | 800.831.7133 | pentair.com

All indicated Pentair trademarks and logos are property of Pentair. Third party registered and unregistered trademarks and logos are the property of their respective owners.

©2023 Pentair. All rights reserved. Pentair.com

PI-35319/2023

R-23

DB:dh
03-12-24

**RESOLUTION INTRODUCING AND APPROVING 2024 BUDGET FOR
CAMDEN SPECIAL SERVICES DISTRICT**

WHEREAS, pursuant to N.J.S.A. 40:56-84, the City Council of the City of Camden desires to approve the Camden Special Services District 2024 Budget; and

WHEREAS, Camden Special Services District 2024 annual budget and report was approved at their February 7, 2024 Board of Directors Meeting and presented to the Mayor and City Council for review on March 12, 2024; now, therefore

BE IT RESOLVED, by the City Council of the City of Camden that it hereby determines that the Camden Special Services District 2024 Budget is hereby approved.

BE IT FURTHER RESOLVED, that pursuant to N.J.S.A. 52:27BBB-23, a true copy of this Resolution shall be forwarded to the State Commissioner of Community Affairs, who shall have ten (10) days from the receipt thereof to veto this Resolution. All notices of veto shall be filed in the Office of the Municipal Clerk.

Date: March 12, 2024

The above has been reviewed
and approved as to form.



DANIEL S. BLACKBURN
City Attorney

ANGEL FUENTES
President, City Council

ATTEST: _____
LUIS PASTORIZA
Municipal Clerk



CITY OF CAMDEN — CITY COUNCIL ACTION REQUEST FORM

COUNCIL MEETING DATE: 3/12/24

TO: City Council
FROM: Timothy J. Cunningham, Business Administrator

TITLE OF ORDINANCE/RESOLUTION: Resolution Introducing And Approving The 2024 Budget For The Camden Special Services District.

Point of Contact:	Timothy J. Cunningham	Administration	7150	
	Name	Department-Division-Bureau	Phone	Email

ENDORSEMENTS

	Recommend Approval (Y/N)	Signature	Date	Comments
Responsible				
Department Director				
Supporting Department Director (if necessary)				
Director of Grants Management				
Qualified Purchasing Agent				
Director of Finance				

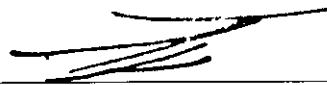
Approved by:  _____ Date: 2.23.24

Business Administrator Signature Date

- Attachments (list and attach all available):
1. Waiver Request Form Attached for State DCA/DLGS Approval - (If applicable)¹
 2. Certification of Funds²
 3. Addition supporting documents.

"Walk-on" note: All walk-on legislation must be pre-approved by the Business Administrator. The Department Director and Contact Person are jointly responsible for delivering all necessary documents to the City Clerk for distribution at the Council Meeting.

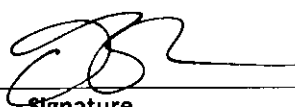
Received by:  _____ Date: FEB 29 2024

City Attorney Signature Date

¹ For Example: Form "A" - Request for approval of Employees Requiring Advice and Consent of Governing Body, Form "D" - Contract Request, Form "E" - Creation/Extension of Services, Form "G" - Grant Approval, Form "H" - Bond Ordinance or Contract Request, Form "I", "Best Price Insurance Contracting" Model Ordinance
² Mandatory for any financial commitment to the City or expenditure of City Funds.



**DOWNTOWN
CAMDEN
BUSINESS IMPROVEMENT DISTRICT**

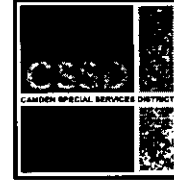

**CAMDEN BUSINESS IMPROVEMENT DISTRICT
2024 BUDGET REPORT**

OVERVIEW

All activities provided through the Camden Business Improvement District (CBID) are intended to supplement and enhance existing city services. The importance and value of providing additional services to support viable, thriving downtowns through business improvement districts has been recognized and utilized in communities worldwide for the last 50 years. Activities and procedures are administered under adherence to Special Improvement District Legislation N.J.S.A. 40:56-65 to 89, and local ordinance MC-5171.

A clean, attractive, and vibrant downtown can deliver significant benefits to the district and the City of Camden.

These include, but are not limited to:

- Encourage and support reentry to the workforce
- Improve quality of life
- Increase the consumer, visitor and resident base
 - attract new customers to businesses
 - attract new visitors to local attractions
 - retain existing resident base and attract new residents
- Improve density of spending
- Support start-up ventures and small businesses
- Create jobs and encourage job growth
- Attract new investment
- Increase property values
- Provide a hub for social and cultural activities
- Contribute to brand of the district and city

Described herein are the planned activities of the Camden Business Improvement District for FY 2024 and the associated budget category.

CAMDEN BUSINESS IMPROVEMENT DISTRICT BUDGET CATEGORY DETAIL

1. Cleaning, Landscape Maintenance, and Hospitality–Yellow Jacket Program

This multi-faceted effort to supplement and enhance city services includes daily removal of trash, debris and hazardous materials from public streets and sidewalks; wiping down and disinfecting high touch public amenities such as trash cans, benches, light poles and parking meters; removing posters, handbills, and lawn signs from public spaces; sweeping sidewalks and curb lines; emptying trash cans and replacing yellow trash bags; removing graffiti from public spaces and storefronts; trimming weeds from sidewalk cracks, curb lines and tree wells; removing snow from handicapped access ramps and fire hydrants; painting yellow curb lines; power-washing; light river skimming; and providing hospitality assists. It also includes working with city offices and Metro Police to report and address public safety and quality of life issues, such as non-working street lights, damaged or missing signage, and illegal dumping. CBID efforts address approximately 1.97 square miles in 153 blocks within the district.

1a. Salaries, Staffing and Shift Coverage

CBID Clean and Safe staff includes an Operations Manager, an Operations Supervisor, an Administrative Assistance/Dispatcher, and the Yellow Jacket Ambassador Team. Full staff of 30 includes: 1 Operations Manager, 1

Operations Supervisor, 1 Administrative Assistant/Hotline Dispatcher, 3 Team Leaders, 2 Hospitality Ambassadors and 22 Special Project/Landscaping/Cleaning Ambassadors. Operations Manager, Operations Supervisor, Dispatcher, Team Leads and Ambassadors are all Camden residents. The account also receives account support from a Regional Manager that is not directly billed to the account.

- We anticipate/budget to maintain expanded team of approximately 28-30 staff through entirety of 2024.
- A new position of Hospitality Ambassador was created this year. There are two (2) Ambassadors budgeted with this distinction.
- Block by Block, our current Clean and Safe contractor, is under contract until end of September 2024, at which point we have the option to renew the contract for an additional 12 months to the end of September 2025. We anticipate renewing for a second year with a 3% across the board pay increase. CSSD will bid for a new contract for a new two-year term Summer 2025. Pay rates, staffing levels and employee residency requirements will remain in place with renewal of contract for additional two year period.
- We anticipate keeping hourly rates and salary levels until the renewal period begins Oct 2024. At that point, we anticipate a 3% across the board wage rate increase.
 - Ambassadors: \$17.50 per hour
 - Hospitality Ambassadors: \$20.25 per hour
 - Team Leaders: 21.65 per hour
 - Administrative Assistant/Hotline Dispatcher: \$20.93 per hour
 - Operations Manager – Salaried, Camden Resident
 - Operations Supervisor – Salaried, Camden Resident
- Additional Shift Coverage – “Second Shift” will continue for Special Projects, enhanced cleaning and to extend coverage. This is a smaller crew than main shift.
 - Shift #1 - 7 days a week 6 am – 2:30 pm
 - Shift #2 - 7 days a week 10:30 am – 6 pm
- Improved Response Time and Visibility
 - Administrative Assistant/Hotline Dispatcher covers hotline, scheduling, customer service, response notification and management.
 - Special Projects team available for quick response to issues and calls to Hotline
 - Increased attendance at Special Events and Community Events
 - Advertised Hotline Number for reporting concerns
 - New equipment for more efficient cleaning
 - Expansion of power-washing frequency and locations
 - Expansion of general painting services such as curb lines and graffiti abatement on vacant property (with owner approval)
 - Branding and visibility improvements include a new website, graphic “wraps” for trucks and portable cleaning stations, A-Frames, social media, etc.
 - Buzz the Bee mascot and Ambassador welcoming presence at District and Community Events

1b. Benefits

All benefits are provided to CSSD Ambassadors and staff through contractor. These include:

- Health, Dental and Life Insurance
- 8 Holidays and Birthday paid time off
- Vacation and Sick Time

1c. Equipment and Supplies

Covers supplies and day to day (non-capital) equipment needed to run the program. Actual number may vary over the course of the year:

- Capital Equipment – 3 billy goats, 3 blowers, 12 mega brute cans, 2 mowers, 2 trailers, 4 trimmers, 20 port battery charger, laptop, lockers, furniture and equipment
- Federal, State and Local Licensing/Permitting
- Fuel and Maintenance for 4 trucks, power washer and new equipment

- Vehicle Insurance
- Communication/GPS devices
- Cleaning and maintenance equipment and supplies, uniforms, and office supplies

1d. Administration and Operations Implementation and Ongoing Support

Covers general contract administration and management:

- Administrative management and oversight
- Staff recruitment, background checks, training
- Awards and Recognition
- Postage and Shipping

2. Landscaping and Placemaking – Multi-year Initiatives

Landscaping and placemaking improvements include multiple initiatives to beautify and activate the district.

2a. High Traffic Corridor Landscaping

Beautification efforts may include benches, planters filled with annuals and perennials, hanging baskets, banners, trash cans, pole wraps, seasonal displays with additional landscape maintenance and annual and perennial plantings in existing planters and landscape beds and in Roosevelt Plaza Park. Most of these projects are multi-year efforts. Includes plantings and maintenance of various parks and public spaces downtown, including Cooper Poynt Park and related areas.

2b. Cooper Plaza and MLK Streetscape

CBID will take on responsibility of maintenance, installation, design, etc. of landscaping efforts along these main and unique thoroughfares. The budget line item here reflects the costs of maintaining a high-level of quality landscaping along these two identified corridors. An assortment of medians, pocket parks and related high-service need areas are covered under this line item.

2c. Tree Work (Removal, Trim, Planting)

Work will continue on the larger commercial corridors of Federal, Market, Cooper and MLK – in areas not impacted by other road improvement projects or previous planting efforts. Work will also take place and expand in the neighborhoods and in partnership with various neighborhood groups and non-profit organizations. Replace dead trees and/or fill empty tree wells in the same commercial corridors identified for tree removal. Trim and maintain existing trees as necessary. This scope of work will continue and maintain momentum for the significant investments made to the urban tree canopy in 2022 and 2023.

2d. Events and Placemaking

Partner with various neighborhood and existing non-profit groups to support projects that honor the individuality of the communities within the CBID boundaries and activate public spaces. These district neighborhoods include North Camden, Cooper Grant, Lanning Square, etc. and include projects created in partnership with the communities the CBID serves. Projects could include murals, additional decorations/banners, tree work, events and temporary activations, lunchtime concerts, the Downtown Arts Crawl, storefront activations, economic development, etc. Additional items covered include costs of events and placemaking activations throughout the District.

2e. Seasonal Displays, Banners, Pole Wraps

Includes the purchase and installation of holiday lighting along major commercial corridors, holiday/non-holiday banners, decorative pole wraps, and other temporary/seasonal interventions and displays throughout the district and along key corridors.

2f. Trashcan Installation

Pricing includes the purchase and installation of approximately new cans, with lockable side doors, lids and options for branding. This should decrease the amount of trash discarded on the ground. Funds also cover replacement parts and liners. The CBID will also investigate options for recycling containers if appropriate in certain high-traffic locations.

2g. Façade Improvement Grant Program

A matching grant program intended for small businesses and property owners to repair and restore buildings in the District. Grant funds are awarded through a committee structure and be dispersed on a dollar for dollar matching basis up to \$25,000 per project.

3. Marketing, Branding, Communication

Efforts will address website, social media, branding, public relations, and connecting the public, residents and employees to local businesses.

3a. Website and Graphic Design

Funds to cover the ongoing maintenance and updating of the new CSSD/CBID website, www.mydowntowncamden.com. The website will allow for greater connection to membership and better promote the district. Hosting allows the CBID to post a website onto the internet. Efforts will further our commitment to promote the local businesses to generate more activity in the district. The CBID is partnering with HopeWorks on the redesign and maintenance of the website.

3b. Public Relations & Strategic Communications

Strategic communications includes any costs associated with the creation of compelling content. Public relations includes the use of third party contractors to engage press outlets to promote positive stories about the organization and the district.

3c. Photo and Video

The creation of engaging and shareable digital content (videos, pictures, stories, links, etc.) to help promote the district. Videos and photography of various CBID initiatives/events. Digital and print advertising for various events, small businesses, employment opportunities, etc.

3d. Email Marketing

The creation and dissemination of monthly email updates to community members and stakeholders with statistics, info-graphics, news and information. Cost reflects the use of email marketing platforms and associated consultant fees.

3e. Print Materials and Collateral

The creation of ongoing communications channels in print is also an important communications channel and includes items such as flyers, newsletters, posters, ad cards, and various other elements. This will promote the businesses, the CBID and the district.

3f. Events, Sponsors, Ads

Hosting events, attending events, sponsoring events and related advertisement spending. Activities to include participation in job fairs, hosting events for small businesses, community members, broker tours to showcase vacant space in the District, etc.

4. Administration

This category covers the administrative responsibilities for overall CBID activities. Implementation of the CBID currently requires a staff of four (4) as well as contracted professional services for the provision of all office and staff support services.

4a. Salaries, Fringe and Benefits

Administrative staffing for the CBID includes direct salary, taxes, retirement benefits, health/dental/vision insurance, disability insurance, and life insurance. This reflects associated costs for three (3) direct CSSD/CBID employees.

4b. Filing Fees

Annual NJDMV registration for work trucks, misc. registrations.

4c. Bank Charges

Bank checks and fees.

4d. Professional Development

Membership in the International Downtown Association (IDA) and attendance at IDA sponsored conference gives the CSSD access to experts in the field and opportunities to learn from other Business Improvement Districts. Opportunities for continuing education for a growing staff. Additional costs include membership to the South Jersey Chamber of Commerce, NJ Downtown and Urban Land Institute.

4e. Professional Services

Professional services for legal counsel; accountant for annual audit; controller for processing checks and invoices, tax preparation and budget oversight; payroll; legal counsel; board meeting support; and consultants such as landscape architects and engineers for placemaking improvement projects.

5. Operating

Operating expenses cover the CSSD/CBID garage located at 101 Newtown Avenue, CSSD deployment space at 201 Market Street, staff parking at 199 Market Street and office space for CSSD administrative staff at The Florio Building for Public Service, 200 Federal Street. Other costs include maintenance and repair projects, exterminating, security, insurance, office supplies and equipment.

5a. Facilities

Budget includes rent for CSSD office space at the James J. Florio Center for Public Service and the CSSD operations garage at 101 Newtown Avenue and 201 Market Street. Additional funds are budgeted for potential property acquisition and related due diligence costs for a new building.

5b. Utilities

Rent, water and sewer, gas, electric, comcast, computer, fire monitoring and security, IT support for CSSD office space, dispatch center and garage.

5c. Maintenance and Equipment

Includes fire inspections, extermination, repair of small equipment and purchase of maintenance vehicles including truck, pressure washing equipment, truck wraps and other equipment as needed. Also includes office equipment associated with CSSD office space.

5d. Insurance

Commercial, Commercial Umbrella, Inland Marine, Workers Comp, D&O, Commercial Excess, ERISA Bond, etc. as required by funding sources, contracts, rental facilities and as needed to protect the CSSD and the CBID.

5e. Office Supplies

Stationary, postage, cell phones, copier, quick book checks, legal ads and general office supplies. Includes cell phone reimbursement for staff, as well as legal noticing as required by local and state ordinance.

6. Depreciation

Annual depreciation expenses related to capital per tax code. Deprecation expenses are not allocated at this time to the CBID.

**ITEMIZED BUDGET AND SUMMARY OF CATEGORIES OF COST CHARGEABLE
per § 461-7. Annual Budget, Hearing and Assessments**

Terms per statute –

Annual Improvements means any reconstruction, replacement or repair of trees and plantings, furniture, shelters, or other facilities for the enjoyment of pedestrians, or any other local improvement benefits properties within the district.

Costs with respect to annual improvements to and operation and maintenance of the district mean costs incurred or to be incurred in connection with annual improvements to and operation and maintenance of the district.

- (1) No costs.
- (2) Amount of costs to be charged and assessed against properties benefited in the district in proportion to benefits which shall be the aggregate of costs of annual improvements to be made in the district during the ensuing year:
100% of total \$665,842 - Budget Category 2 - Landscaping and Placemaking
- (3) Amount of costs to be charged and assessed against properties benefited in the district in 2024:
\$1,944,597.00 for all costs

Line-Item	Budget Category	Amount	% of Budget
Cleaning	Category 1	\$1,408,665	52%
Landscaping	Category 2	\$665,842	24%
Marketing	Category 3	\$18,307	1%
Administration	Category 4	\$400,174	15%
Operating	Category 5	\$233,879	9%
Depreciation	Category 6	\$ -	0%
			100%

Budget Notations

The CSSD budget is supported by contributions, grants, and fee-for-service contracts. CSSD expenses relative to grant and fee-for-service contracts and a percentage of all shared fixed costs are not included in the CBID budget.

There were unexpended funds from 2023 in the amount of \$728,000 applied towards the 2024 budget, pursuant to:

Special Improvement District Legislation N.J.S.A. 40:56-65 to 89 as amended
40:56-80 Any balances to the credit of the account and remaining unexpended at the end of the fiscal year shall be conserved and applied towards the financial requirements of the succeeding year.

GOALS AND OBJECTIVES

The Camden Downtown is one of the important gateways to the South Jersey region, serving as a center for commerce, transportation, education, health care and government. Its strategic assets can project a vibrant, well-maintained, safe, clean and attractive downtown. Revitalization should be pedestrian friendly and provide for a vibrant business environment with mercantile and service type businesses, providing an environment that supports shopping, dining, socializing, entertainment and commercial activities for daytime and evening hours. Success relies on an integrated community approach and the maintenance of focused community partnerships.

GOALS AND OBJECTIVES AND THE BUDGET CATEGORIES THAT CONTRIBUTE TO GOALS AND OBJECTIVES

Goal #1 Implement and manage a Business Improvement District to support growth of a vital, healthy, thriving district for everyone - residents, businesses, employers, employees, students and visitors.

Objectives

- To be a reliable partner to all represented within the CBID, by working together to honor the community's traditions and maintain and support community values
- To develop Public/Private collaboration that encourages investment, interest, ideas, increased foot traffic and activity to local businesses, educational and health facilities, local attractions, public events, and support neighborhood growth
- To encourage public input, through meetings and surveys, to help identify targeted initiatives
- To continue to hire local residents to work on the Yellow Jacket Ambassador team, pay a fair hourly rate with benefits and increase staffing

Supported by Budget Line Items

#1 **Cleaning** – hiring local residents contributes to a vital, healthy, thriving district for everyone

#4 **Administration** – 3 staff persons to manage BID activities including Public/Private partnerships and community projects.

#5 **Operating** – supports the total operation, support of garage and office space and supplies, insurance coverage and needed capital equipment upgrades. Supports rental of garage and office for staff and storage of equipment and supplies.

Goal #2 Provide dedicated and enhanced CBID on-the-street activities to create a more welcoming district

Objectives

- To provide enhanced cleaning, landscaping, and hospitality assists
- To increase staffing and maintain services seven days a week
- To clean streets and sidewalks in neighborhoods within the CBID catchment area
- To be accountable, produce and measure results

Supported by Budget Line items

#1 **Cleaning** – projected increase in staffing to 28-30 to cover a larger area including neighborhoods, and expanded shifts/services.

#2 **Landscaping/Placemaking**– enhancements will include tree removals and replacements, banners, planters and hanging baskets, seasonal displays, etc. This also include holiday lighting interventions, economic development investments, etc.

Goal #3 Administer the District Management Corporation

Objectives

- To fairly represent the various stakeholders in the CBID
- To work with a Board of Directors that represents the district

- Participate in neighborhood community meetings to establish and maintain cooperation, understanding, collaboration
- To manage the district to be inclusive of all interests and represent the downtown as identified on the property map
- To maintain a balanced budget

Supported by Budget Line Items

- #4 **Administration** – CBID staff will work to manage the CBID professionally and fairly, engaging those represented in the district, contracting for professional services and participating in professional development opportunities to continue learning about CBID management
- #5 **Operating** – general expenses to support the program, rent, utilities, maintenance, insurance, supplies

Goal #4 Promote and support the various communities through new marketing and branding/identity efforts to drive customers, visitors, residents, employees into local businesses and attractions and support community and neighborhood initiatives.

Objectives

- To utilize local sourcing when available, appropriate and economically responsible
- To develop digital and print marketing materials to promote the district
- To disseminate district news to the community via on-going communication with community groups, neighborhood associations, religious institutions, business groups

Supported by Budget Line Items

- #3 **Marketing** – digital and print materials, website, social media, and professional consultant to manage for optimal results. Creation and management of mydowntown.com website.
- #4 **Administration** – CBID staff to manage.

PAGE INTENTIONALLY LEFT BLANK



CAMDEN SPECIAL SERVICES DISTRICT

**FINAL
2024 BUDGET
APPROVED - 2.7.24**

CSSD/CBID BUDGET		CSSD DETAIL	CBID DETAIL
INCOME			
Grants	\$ 145,180		
Project Management	\$ 913,384		
Contributions	\$ 104,000		
		\$ 1,162,564	
2023 Assessment (Carry-Over)	\$ 782,000		
2024 Assessment	\$ 1,944,597		\$ 2,726,597
Total Revenue and Assessment	\$ 3,889,161	\$ 1,162,564	\$ 2,726,597
EXPENSES			
Clean and Safe "Yellow Jackets" Program	\$ 1,933,632	\$ 524,967	\$ 1,408,665
Landscaping and Placemaking	\$ 997,598	\$ 331,756	\$ 665,842
Marketing	\$ 25,500	\$ 7,463	\$ 18,037
Administration	\$ 565,765	\$ 165,591	\$ 400,174
Operations	\$ 321,968	\$ 88,089	\$ 233,879
Depreciation	\$ 10,392	\$ 10,392	\$ -
Total Expenses	\$ 3,854,855	\$ 1,128,258	\$ 2,726,597

CAMDEN BUSINESS IMPROVEMENT DISTRICT – 2024 DETAILED BUDGET

CBID 2024 Budget - Detailed			CBID
INCOME			
	2023 Assessment		\$ 782,000
	2024 Assessment		\$ 1,944,597
Total Revenue and Assessment			\$ 2,726,597
EXPENSES			
1	Clean and Safe "Yellow Jackets" Program		\$ 1,408,665
a.	<i>Salaries</i>	\$ 1,091,985	
b.	<i>Benefits</i>	\$ 92,661	
c.	<i>Equipment and Supplies</i>	\$ 103,517	
d.	<i>Administration</i>	\$ 120,502	
2	Landscaping and Placemaking		\$ 665,842
a.	<i>High Traffic Corridor Landscaping</i>	\$ 98,500	
b.	<i>Cooper Plaza and MLK Streetscape</i>	\$ 140,000	
c.	<i>Tree Work</i>	\$ 55,000	
d.	<i>Events and Placemaking</i>	\$ 110,105	
e.	<i>Seasonal Lights, Displays, Banners, Pole Wraps</i>	\$ 72,000	
f.	<i>Trashcan Installation</i>	\$ 40,237	
g.	<i>Façade Improvement Grant Program</i>	\$ 150,000	
3	Marketing		\$ 18,037
a.	<i>Website and Graphic Design</i>	\$ 4,368	
b.	<i>Public Relations & Strategic Communications</i>	\$ 3,276	
c.	<i>Photo/Video</i>	\$ 2,184	
d.	<i>Email Marketing</i>	\$ 2,184	
e.	<i>Printing and Collateral</i>	\$ 2,184	
f.	<i>Events, Sponsors, Ads</i>	\$ 3,276	
4	Administration		\$ 400,174
a.	<i>Salaries, Fringe, Benefits</i>	\$ 312,075	
b.	<i>Filing Fees</i>	\$ 707	
c.	<i>Bank Charges</i>	\$ 354	
d.	<i>Professional Development</i>	\$ 6,475	
e.	<i>Professional Services</i>	\$ 80,562	
5	Operations		\$ 233,879
a.	<i>Facilities</i>	\$ 154,025	
b.	<i>Utilities</i>	\$ 18,319	
c.	<i>Maintenance and Equipment</i>	\$ 31,037	
d.	<i>Insurance</i>	\$ 21,785	
e.	<i>Office Supplies</i>	\$ 8,713	
6	Depreciation		\$ -
Total Expenses			\$ 2,726,597



CAMDEN SPECIAL SERVICES DISTRICT

**FINAL
2024 BUDGET
APPROVED - 2.7.24**

CSSD/CBID BUDGET			CSSD DETAIL	CBID DETAIL
INCOME				
Grants	\$	145,180		
Project Management	\$	913,384		
Contributions	\$	104,000		
			\$	1,162,564
2023 Assessment (Carry-Over)	\$	782,000		
2024 Assessment	\$	1,944,597		\$ 2,726,597
Total Revenue and Assessment	\$	3,889,161	\$ 1,162,564	\$ 2,726,597
EXPENSES				
Clean and Safe "Yellow Jackets" Program	\$	1,933,632	\$ 524,967	\$ 1,408,665
Landscaping and Placemaking	\$	997,598	\$ 331,756	\$ 665,842
Marketing	\$	25,500	\$ 7,463	\$ 18,037
Administration	\$	565,765	\$ 165,591	\$ 400,174
Operations	\$	321,968	\$ 88,089	\$ 233,879
Depreciation	\$	10,392	\$ 10,392	\$ -
Total Expenses	\$	3,854,855	\$ 1,128,258	\$ 2,726,597

CBID 2024 Budget - Detailed			CBID
INCOME			
	2023 Assessment		\$ 782,000
	2024 Assessment		\$ 1,944,597
Total Revenue and Assessment			\$ 2,726,597
EXPENSES			
1	Clean and Safe "Yellow Jackets" Program		\$ 1,408,665
a.	Salaries	\$ 1,091,985	
b.	Benefits	\$ 92,661	
c.	Equipment and Supplies	\$ 103,517	
d.	Administration	\$ 120,502	
2	Landscaping and Placemaking		\$ 665,842
a.	High Traffic Corridor Landscaping	\$ 98,500	
b.	Cooper Plaza and MLK Streetscape	\$ 140,000	
c.	Tree Work	\$ 55,000	
d.	Events and Placemaking	\$ 110,105	
e.	Seasonal Lights, Displays, Banners, Pole Wraps	\$ 72,000	
f.	Trashcan Installation	\$ 40,237	
g.	Façade Improvement Grant Program	\$ 150,000	
3	Marketing		\$ 18,037
a.	Website and Graphic Design	\$ 4,368	
b.	Public Relations & Strategic Communications	\$ 3,276	
c.	Photo/Video	\$ 2,184	
d.	Email Marketing	\$ 2,184	
e.	Printing and Collateral	\$ 2,184	
f.	Events, Sponsors, Ads	\$ 3,276	
4	Administration		\$ 400,174
a.	Salaries, Fringe, Benefits	\$ 312,075	
b.	Filing Fees	\$ 707	
c.	Bank Charges	\$ 354	
d.	Professional Development	\$ 6,475	
e.	Professional Services	\$ 80,562	
5	Operations		\$ 233,879
a.	Facilities	\$ 154,025	
b.	Utilities	\$ 18,319	
c.	Maintenance and Equipment	\$ 31,037	
d.	Insurance	\$ 21,785	
e.	Office Supplies	\$ 8,713	
6	Depreciation		\$ -
Total Expenses			\$ 2,726,597

R-24

SE:dh
03-12-24

RESOLUTION AUTHORIZING AND RATIFYING AN EMERGENCY PROCUREMENT AND PAYMENT OF SAME TO THE ORIGINAL W. HARGROVE DEMOLITION CO. FOR THE EMERGENCY DEMOLITION OF 1437 BELLEVIEW AVENUE, BLOCK 1274, LOT 98 AND IMPOSING A MUNICIPAL LIEN AGAINST THE PROPERTY

WHEREAS, on February 12, 2024, the City Construction Official inspected a building structure which is located at 1437 Belleview Avenue, Block 1274, Lot 98; and

WHEREAS, upon inspection, the Construction Official determined that the building structure located at 1437 Belleview Avenue, Block 1274, Lot 98 was an Unsafe Structure which constitutes a danger to the health, safety and welfare of the residents of the City of Camden requiring prompt action; and

WHEREAS, on February 12, 2024, it was determined that the building structure located at 1437 Belleview Avenue, Block 1274, Lot 98 required emergency demolition, including the removal of all structures, contents and debris, whether above or below ground and the final restoration and grading of the property; and

WHEREAS, the City reached out to The Original W. Hargrove Demolition, Inc., for bid of the emergency demolition of the building structure located at 1437 Belleview Avenue, Block 1274, Lot 98, including the removal of all structures, contents, and debris, whether above or below ground and the final restoration and grading of the property; and

WHEREAS, the City of Camden received a lump sum bid of SEVENTY-EIGHT THOUSAND DOLLARS (\$78,000.00) from The Original W. Hargrove Demolition, Inc., for the emergency demolition including the removal of all structures, contents, and debris, whether above or below ground and the final restoration and grading of the property at 1437 Belleview Avenue, Block 1274, Lot 98, Camden, NJ; and

WHEREAS, the City of Camden entered into a contract with The Original W. Hargrove Demolition, Inc. for SEVENTY-EIGHT THOUSAND DOLLARS (\$78,000.00) for the emergency demolition including the removal of all structures, contents and debris, whether above or below ground; the final restoration and grading of 1437 Belleview Avenue, Block 1274, Lot 98, Camden NJ; and

WHEREAS, pursuant to the directive of the Division of Local Government Services, a certification has been attached hereto which certifies that the funds for this expenditure are available and appropriated under the budget for the City of Camden, under line item "4-01-E4-605-901", and said certification has been signed by the Chief Financial Officer and approved as to form by the City Attorney; and

WHEREAS, the City of Camden is permitted by New Jersey law, N.J.S.A. 40:48 - 1.1 et seq. and the City of Camden Code to impose a municipal lien in the amount of SEVENTY-EIGHT THOUSAND DOLLARS (\$78,000.00) on the property at 1437 Belleview Avenue, Block 1274, Lot 98, Camden, NJ or alternatively, to enforce the payment of SEVENTY-EIGHT THOUSAND DOLLARS (\$78,000.00), together with interest, as a debt of the owner of the property for the City's costs incurred for the emergency demolition including the removal of debris, final restoration and grading of 1437 Belleview Avenue, Block 1274, Lot 98, Camden, NJ; now therefore

BE IT RESOLVED, by the City Council of the City of Camden as follows:

1. The appropriate person in City of Camden shall have the authority to impose and record a lien in the amount of SEVENTY-EIGHT THOUSAND DOLLARS (\$78,000.00) on the property located at 1437 Belleview Avenue, Block 1274,

Lot 98, for the costs incurred for the emergency demolition including the removal of debris, final restoration and grading.

2. The municipal lien in the amount of SEVENTY-EIGHT THOUSAND DOLLARS (\$78,000.00) for the property located at 1437 Belleview Avenue, Block 1274, Lot 98, Camden, NJ, shall remain on the property until the owner or other interested party satisfies this amount.
3. Interest and other costs shall accrue on the lien amount as allowed by law.
4. The City shall also have the authority pursuant to N.J.S.A. 40:48-1.1 and the Camden City Code to enforce the payment of the costs incurred by the City in the amount of SEVENTY-EIGHT THOUSAND DOLLARS (\$78,000.00) for the demolition including the removal of debris, final restoration and grading at 1437 Belleview Avenue, Block 1274, Lot 98, Camden, NJ, together with interest, as a debt of the owner of the property, by instituting an action at law for the collection of this sum.

BE IT FURTHER RESOLVED, that pursuant to N.J.S.A. 52:27BBB-23, a true copy of this Resolution shall be forwarded to the State Commissioner of Community Affairs, who shall have ten (10) days from the receipt thereof to veto this Resolution. All notices of veto shall be filed in the Office of the Municipal Clerk.

Date: March 12, 2024

The above has been reviewed
and approved as to form.



DANIELS. BLACKBURN
City Attorney

ANGEL FUENTES
President, City Council

ATTEST: _____
LUIS PASTORIZA
Municipal Clerk

CITY OF CAMDEN

CERTIFICATION AS TO THE AVAILABILITY OF FUNDS

I CERTIFY, DIRECTOR FOR THE FINANCE DEPARTMENT FOR THE CITY OF CAMDEN, THAT WITH RESPECT TO THE AWARD OF A CONTRACT OR EXPENDITURE OF FUNDS TO: ORIGINAL W. HARGROVE DEMOLITION CO

THAT THE FUNDS ARE AVAILABLE AS OF THE DATE OF THIS RESOLUTION/CERTIFICATION, FROM ONE OF THE FOLLOWING:

• BUDGET APPROPRIATION: 4-01-E4-605-901
AMOUNT \$ 78,000.00

APPROPRIATION RESERVE:

AMOUNT: \$

• DEDICATED BY RIDER:

AMOUNT: \$

• RESERVE FOR STATE AND FEDERAL GRANT:

AMOUNT \$

• CAPITAL ORDINANCE

AMOUNT: \$

• TRUST ACCOUNT:

AMOUNT: \$

DETERMINATION OF VALUE CERTIFICATION

I CERTIFY, AS CHIEF FINANCIAL OFFICER, THAT THE ANTICIPATED VALUE OF THE CONTRACT, OVER THE FULL LIFE, WILL BE \$ 78,000.00

DESCRIPTION OF THE GOODS AND SERVICES TO BE PROCURED: RESOLUTION AUTHORIZING AND RATIFYING EMERGENCY PROCUREMENT AND PAYMENT OF SAME TO THE ORIGINAL W. HARGROVE DEMOLITION CO, INC FOR 1437 BELLEVIEW AVENUE , BLOCK 1274, LOT 98 AND IMPOSING A MUNICIPAL LIEN AGAINST THE PROPERTY

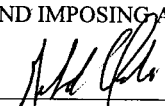

Gerald C. Seneski

Director of Finance

Date: 2/2



CITY OF CAMDEN — CITY COUNCIL ACTION REQUEST FORM

COUNCIL MEETING DATE: 03/12/2024

TO: City Council
FROM: Timothy J. Cunningham, Business Administrator

TITLE OF ORDINANCE/RESOLUTION: RESOLUTION AUTHORIZING AND RATIFYING EMERGENCY PROCUREMENT AND PAYMENT OF SAME TO THE ORIGINAL W HARGROVE DEMOLITION CO, INC, FOR 1437 BELLEVIEW AVENUE, BLOCK 1274, LOT 98 AND IMPOSING A MUNICIPAL LIEN AGAINST THE PROPERTY

Point of Contact:	Lateefah Chandler	Admin-Purchasing	856-757-7475	lachandl@ci.camden.nj.us
	Name	Department- Division- Bureau	Phone	Email

ENDORSEMENTS

	Recommend Approval (Y/N)	Signature	Date	Comments
Responsible				
Department Director				
Supporting Department Director (if necessary)				
Director of Grants Management				
Qualified Purchasing Agent	Y		2/21/24	
Director of Finance				
Approved by:			2/22	
Business Administrator		Signature	Date	

Attachments (list and attach all available):

1. Waiver Request Form Attached for State DCA/DLGS Approval - (If applicable)¹
2. Certification of Funds²
3. Addition supporting documents.

"Walk-on" note: All walk-on legislation must be pre-approved by the Business Administrator. The Department Director and Contact Person are jointly responsible for delivering all necessary documents to the City Clerk for distribution at the Council Meeting.

FEB 29 2024

Received by: City Attorney	Signature	Date
----------------------------	-----------	------

¹ For Example: Form "A" - Request for approval of Employees Requiring Advice and Consent of Governing Body, Form "D" - Contract Request, Form "E" - Creation/Extension of Services, Form "G" - Grant Approval, Form "H" - Bond Ordinance or Contract Request, Form "I", "Best Price Insurance Contracting" Model Ordinance

² Mandatory for any financial commitment to the City or expenditure of City Funds.

CAMDEN CITY
 520 MARKET STREET
 P O BOX 95120
 CAMDEN, NJ 08101-5120
 TEL (856)757-7000

REQUISITION	
NO.	R2400467

SHIP TO	DEPT OF PUBLIC WORKS 101 NEWTON AVENUE CAMDEN, NJ 08103 ATTN: ANGELA WATKINS
VENDOR	VENDOR #: HAR04 THE ORIGINAL W. HARGROVE DEMOLITION CO. 1507 STATE STREET CAMDEN, NJ 08105

ORDER DATE: 02/14/24
 DELIVERY DATE: 02/14/24
 STATE CONTRACT:
 F.O.B. TERMS:

QTY/UNIT	DESCRIPTION	ACCOUNT NO.	UNIT PRICE	TOTAL COST
1.00 EA	ER DEMO - 1437 BELLEVIEW AVE Emergency contract to provide for the demolition of a residential property, the removal of all structures, contents and all other debris, whether above or below ground, at 1437 Belleview Ave (Blk 1274/Lot 98), final restoration and grading of this property and stucco of adjoining walls at 1439 Belleview Ave in the City of Camden. Bid dated 2/14/24	4-01-E4-605-901	78,000.0000	78,000.00
			TOTAL	78,000.00

CITY OF CAMDEN
PURCHASING BUREAU
2024 FEB 21 AM 8:50

Approved:

I hereby certify that the work or supplies specified are necessary for the proper transaction of the business of this bureau or office.

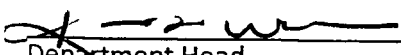
 Department Head 2-14-24
 Date

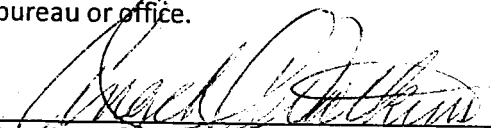
 Receiver of Goods 2/14/24
 Date

FORWARD THIS COPY OF THE REQUISITION TO THE PURCHASING BUREAU

EXECUTIVE SUMMARY

TITLE OF ORDINANCE/RESOLUTION: RESOLUTION AUTHORIZING AND RATIFYING EMERGENCY PROCUREMENT AND PAYMENT OF SAME TO THE ORIGINAL W HARGROVE DEMOLITION CO, INC, FOR 1437 BELLEVIEW AVENUE, BLOCK 1274, LOT 98 AND IMPOSING A MUNICIPAL LIEN AGAINST THE PROPERTY

FACTS/BACKGROUND: (Executive level details. Short concise bullets)

- Ratify the emergency demolition and payment of same to The Original W. Hargrove Demolition Co., Inc., 1507 State Street, Camden NJ 08103 at 1437 Belleview Avenue, Block 1274 Lot 98.
- On 2/12/2024 the Construction Office declared unsafe structure and imminent hazard due to partial roof collapse extreme water infiltration and damaging occupied adjoining property
- Received three (3) quotes Hargrove (\$78,000), Winzinger (\$93,000) & Caravella (\$176,000.00)
- The City of Camden Code will impose a municipal lien against this property for the amount of the costs incurred by the City for the demolition and any additional expenses

AMOUNT OF PROPOSED CONTRACT or TOTAL COST OF PROPOSAL: \$78,000.00

PROCUREMENT PROCESS: N.J.S.A. 40A: 11-6 (Emergency)

APPROPRIATION NUMBER: 4-01-E4-605-901

IMPACT STATEMENT:

- ER Demolition work started 02/14/2024

SUBJECT MATTER EXPERTS/ADVOCATES:

- N/A

COORDINATION:

- N/A

Prepared by: LATEEAH CHANDLER

856-757-7159

Name

Phone/Email

**STATE OF NEW JERSEY
DEPARTMENT OF COMMUNITY AFFAIRS
DIVISION OF LOCAL GOVERNMENT SERVICES
CONTRACT REQUEST FORM**

This form must be filled out in its entirety and is intended to provide the Division with appropriate information to determine whether to approve a new or extended service. Please provide any additional information you believe will help the Division make an informed decision.

Municipality	CITY OF CAMDEN
Professional Service or EUS Type	N/A
Name of Vendor	THE ORIGINAL W HARGROVE DEMOLITION
Purpose or Need for service:	EMERGENCY DEMOLITION AT 1437 BELLEVIEW AVENUE BLOCK 1274 LOT 98
Contract Award Amount	\$78,000.00
Term of Contract	~5 DAYS
Temporary or Seasonal	N/A
Grant Funded (attach appropriate documentation allowing for service through grant funds)	NO
Please explain the procurement process (i.e. bids, RFQ, competitive contracting, etc.)	NJSA 40A:11-6
Were other proposals received? If so, please attach the names and amounts for each proposal received?	YES WINZINGER \$93,000.00 CARAVELLA \$176,000.00

Please attach the RFP, evaluation memoranda or evaluation forms used to evaluate the vendors and a list of all bidders and the bid amounts associated with each bidder.

If the lowest bidder was not selected, please have the appropriate personnel sign the certification on page 2.

	Date _____
Mayor's Signature*	
	Date _____
Business Administrator/Manager Signature	

BID PRICE SHEET

EMERGENCY CONTRACT TO PROVIDE FOR THE DEMOLITION OF A RESIDENTIAL PROPERTY, THE REMOVAL OF ALL STRUCTURES, CONTENTS AND ALL OTHER DEBRIS, WHETHER ABOVE OR BELOW GROUND, AT 1437 BELLEVIEW AVENUE, BLOCK 1274, LOT 98, FINAL RESTORATION AND GRADING OF THIS PROPERTY AND STUCCO OF ADJOINING WALL AT 1439 BELLEVIEW AVE IN THE CITY OF CAMDEN

\$ 78,000.⁰⁰
TOTAL

Total Bid Amount in Words: Seventy Eight Thousand
and ⁰⁰/₁₀₀ Dollars

NOTE: THE ABOVE LUMP SUM PAYMENTS MUST INCLUDE ALL COSTS, INCLUDING REMOVAL OF ALL DEBRIS, WHETHER ABOVE OR BELOW GROUND, ASBESTOS ABATEMENT, REMOVAL OF ABOVE GROUND OIL, PROPANE OR OTHER TYPES OF TANKS OR CONTAINERS, INCLUDING ABOVE GROUND OIL, PROPANE OR OTHER TYPES OF TANKS OR CONTAINERS LOCATED IN THE BASEMENT OF THE STRUCTURE(S) TO BE DEMOLISHED, ALL RESTORATION AND GRADING COSTS AND ALL OTHER COSTS.

PLEASE NOTE: GAS AND ELECTRIC SERVICES TO 1437 BELLEVIEW AVENUE, BLOCK 1274, LOT 98, CAMDEN, NEW JERSEY HAVE BEEN DISCONNECTED BY PSE&G.

THE ABOVE LUMP SUM PAYMENTS MUST INCLUDE ALL COSTS ASSOCIATED WITH OTHER DISCONNECTION COSTS AS WELL AS DISCONNECTION OF APPURTENANT EQUIPMENT SUCH AS METERS, REGULATORS, AND GAUGES AND THE COORDINATION AND SCHEDULING THEREOF.

PLEASE NOTE: THE BIDDER WILL NOT BE RESPONSIBLE FOR WATER AND SEWER DISCONNECTS OR FOR THE COSTS FOR THESE WATER AND SEWER DISCONNECTS SINCE THE WATER AND SEWER DISCONNECT SERVICES ARE TO BE PROVIDED BY AMERICAN WATER.

Fees for any additional charges not listed in this bid sheet are expressly not permitted under the contract.

I **HEREBY** submit and confirm this Bid Price Sheet, subject to all requirements and conditions stated in these bid specifications.

Company Name: "The Original" W. Hargrave Demolition Co. Inc.

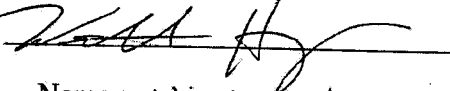
Bidder's Corporate Officer's Signature: 

print name)

Name: William Hargrave

(print title)

Title: President

Date: 02/14/2024.



CERTIFICATE OF ENVIRONMENTAL COMPLIANCE

Name of Contractor: "The Original" W. Hargrove Demolition Co. Inc.

I, William Hargrove, hereby agree to hold harmless the City of Camden, its successors and assignees, or its officials, officers, employees and agents, for any injuries to person or property incurred on losses suffered on account of the demolition of

1437 Bellevue Avenue, Block 1274, Lot 98, Camden

I certify upon inspection of the property that there is no asbestos or visible hazardous tanks. The contractor will not be responsible for the removal of subsurface tanks unless otherwise noted by the City of Camden. If either of these items are identified, they will be removed in accordance with applicable federal, state, and local laws, ordinances, rules and regulations. Including, the New Jersey Department of Labor procedures, rules, and regulations, including providing appropriate documents, affidavits and/or certifications and also N.J.S.A 52:27D - 119 et. Seq.

Asbestos		Tanks	
Yes	No	Yes	No
<u> </u>	<u> X </u>	<u> </u>	<u> X </u>

By: [Signature]
William Hargrove, President

Sworn and subscribed to before me
On this 14th day of February 2024

[Signature]
NOTARY PUBLIC

Kelly-Jo Gipe
NOTARY PUBLIC
STATE OF NEW JERSEY
MY COMMISSION EXPIRES 03/26/2024

CITY OF CAMDEN

EMERGENCY CONTRACT TO PROVIDE FOR THE DEMOLITION OF A RESIDENTIAL PROPERTY, THE REMOVAL OF ALL STRUCTURES, CONTENTS AND ALL OTHER DEBRIS, WHETHER ABOVE OR BELOW GROUND, AT 1437 BELLEVIEW AVENUE, BLOCK 1274, LOT 98, FINAL RESTORATION AND GRADING OF THIS PROPERTY AND STUCCO OF ADJOINING WALL AT 1439 BELLEVIEW AVE IN THE CITY OF CAMDEN

This Emergency Demolition is encompassed by the Standard City Demolition Specifications, which are incorporated by reference and made a part hereto, and the following, special provisions.

On February 12, 2024, the City of Camden Construction Official conducted an inspection of the structure at 1437 Belleview Ave, Block 1274, Lot 98, and determined that it is an unsafe structure and imminent hazard: partial roof collapse due to extreme water infiltration and damaging adjoining occupied property. These unsafe conditions make this structure extremely dangerous to the residents. The Construction Official provided the owner until February 15, 2024 to demolish the structure or correct the unsafe conditions. The owner has failed to do so and the Construction Official has determined that the building structure must be promptly demolished.

By this emergency quote, the City of Camden is seeking one (1) contractor to provide for the demolition of the residential property at 1437 Belleview Ave, Block 1274, Lot 98, the removal of all structures, contents and all other debris, whether above or below ground, and final restoration and grading of the property and stucco of adjoining wall at 1439 Belleview Ave in the City of Camden.

The Contractor must respond by no later than 12:00 pm on February 14, 2024. The Purchasing Bureau will contact the successful vendor by telephone/email with notice to proceed.

Contractor must secure the property immediately after being notified of the award on February 14, 2024 for public safety. A Portable six-foot (6') metal cyclone fence (**hard fencing**) must be erected around the pedestrian walkway(s) of the structure(s) to be demolished. (**NO EXCEPTIONS**). **Any immediate hazards [falling debris, etc.] that has the potential to fall outside of the fencing must be corrected at that time.** Contractor must begin demolition by 8:00 am on Thursday, February 15, 2024.

Contractor shall ensure that dust be kept to a minimum by spraying the site with water during the demolition. Sidewalks should be made passable and left broom clean daily during the course of your demolition operations.

All Contractor signage shall be removed from the worksite at the time the job is completed. This requirement is a condition prior to receipt of final payment.

PLEASE BE ADVISED

- **EMERGENCY CONTRACT TO PROVIDE FOR THE DEMOLITION OF A RESIDENTIAL PROPERTY, THE REMOVAL OF ALL STRUCTURES, CONTENTS AND ALL OTHER DEBRIS, WHETHER ABOVE OR BELOW GROUND, AT 1437 BELLEVIEW AVENUE, BLOCK 1274, LOT 98, FINAL RESTORATION AND GRADING OF THIS PROPERTY AND STUCCO OF ADJOINING WALL AT 1439 BELLEVIEW AVE IN THE CITY OF CAMDEN**
- **Any tanks or containers on the property must be removed from the property and such removal costs shall be included in the bid price sheet. All such removal work shall be done in accordance with and comply with all applicable federal, state, and local laws, ordinances, rules and regulations. Furthermore, the Contractor must comply with the New Jersey Department of Labor procedures, rules, and regulations, including providing appropriate documents, affidavits and/or certifications.**
- **Contractor must secure subject site with sufficient and appropriate security fencing while the Contractor is performing the emergency demolition in order to adequately protect the public health, safety and welfare of the citizens of the City.**
- **All costs for asbestos and tank and/or container removals must be included in the Bid Price Sheet's Lump Sum Payments. The City of Camden will not pay any additional costs for these removals.**
- **AWARD WILL BE BASED ON THE TOTAL AMOUNT OF THE QUOTE.**

***EXCEPTION:** If asbestos or other contamination is verified, then the demolition time schedule is referred to the Construction Official.

A Certificate of Environmental Compliance and Hold Harmless Agreement issued by the City Construction Official are attached to this fax; they must be completed and returned with the Proposal prior to any award and demolition work. Return of the Certificates is MANDATORY; otherwise said proposal will be rejected. The worksite must remain secure until project is properly abated.

The dollar amount for all demolition quotes must be submitted in two written versions as per example.

Example: "Seven thousand five hundred dollars" and \$ 7,500.00

PLEASE NOTE: In the event of a tie for emergency demolition request, the determining factor will be awarded to the contractor who submits their proposal the earliest



CITY OF CAMDEN

DEPARTMENT OF CODE ENFORCEMENT

BUILDING BUREAU

EMERGENCY DEMOLITION

To: Keith Walker, Director of Department of Public Works

From: JAMES R RIZZO, Construction Official

Date: Tuesday, February 13, 2024

SITE: 1437 BELLEVIEW AVE

Owner HELEN SIMMONDS
SAME
CAMDEN, NJ 08103

I hereby certify that all necessary steps required pursuant to UCC 5:23-2.32 have been taken by the Building Bureau prior to issuing this demolition memorandum for above referenced property.

Please process accordingly.

Signed: _____

JAMES R RIZZO, Construction Official

Signed: _____

Building Sub code Official

COMMENTS

1 STUCCO WALL

1439 BELLEVIEW AVE



CITY OF CAMDEN
 520 MARKET STREET
 CAMDEN, NJ 08101
 (856)757-7032

NOTICE OF IMMINENT HAZARD

Application Date:
 Application ID:
 Permit Number:
 Date Permit Issued:
 Notice Date: 2/13/2024
 Violation Number: 2023-00273

IDENTIFICATION

Work Site Location: 1437 BELLEVIEW AVE Block: 1274 Lot: 98 Qual: _____
 Owner in Fee: HELEN SIMMONDS ETAL Contractor/Agent: _____
 Address: 1437 BELLEVIEW AVENUE Address: _____
CAMDEN NEW JERSEY 08103 Telephone: _____
 Telephone: _____

To: Owner Other
 Contractor/Agent
 Date of Inspection: 2/12/2024 Date of Notice: 2/13/2024 Compliance Due Date: 2/15/2024

ACTION

Take NOTICE that as a result of the inspections conducted by this agency on 2/12/2024 of the above property, an imminent hazard has been found to exist pursuant to N.J.S.A. 52:27D-132 and N.J.A.C. 5:23-2.32. The building or structure, or portion thereof, deemed an

**.Partial roof collapse extreme water infiltration
 damaging adjoining occupied property**

As such, you are hereby **ORDERED** to immediately and forthwith vacate the above structure or portion thereof.

Further, you are **ORDERED** to:

- Immediately correct the above noticed imminent hazards so as to render the structure temporarily safe and secure.
- Demolish the above structure by 2/15/2024.

Failure to immediately comply with this **ORDER** may result in the necessary correction being made by the Construction Official at the expense of the property owner pursuant to N.J.A.C. 5:23-2.32(b)5.

Failure to render the structure temporarily safe and secure and/or demolish the structure in accordance with this **ORDER** will result in this matter being forwarded to legal counsel for prosecution, and assessment of penalties up to \$2,000.00 per week per violation. You must immediately declare to the Construction Official, your acceptance or rejection of the terms of this **ORDER**.

If you wish to contest this **ORDER**, you must apply for a stay to a court of competent jurisdiction within 24 hours.

If you have any questions concerning this matter, please call: (856) 757-7032.

By Order of: Date: 02/13/2024
 CITY OF CAMDEN Construction Official

Sent by Certified Mail: _____

Public Service Electric & Gas Company
Demolition
PO Box 710 Newark, NJ 07101-0710
Phone: 1-800-817-3366 Email: Demolition@pseg.com



Date: 1/24/2024

James Rizzo
Construction Official
Department of Code Enforcement
Building Bureau
520 Market St
City Hall, Room 403
PO Box 95120
Camden, NJ 08101-5120

To whom it concerns,

Please be advised; per your request, Electric and Gas services have been disconnected and removed. At this time demolition is permitted to proceed at the service address listed below.

1437 Belleview Ave
Camden

Please notify PSE&G Demolition Department at 1-800-817-3366 if you have any questions or concerns.

PSE&G appreciates the opportunity to service your energy needs and thanks you for your business.

Sincerely,

Rafael Soto

Rafael Soto
Supervisor
PSE&G Demolition Department- Construction Inquiry

**1437 Belleview Ave partial roof
collapse extreme water infiltration
damaging adjoining occupied property
E-DEMO 02-13-2024**

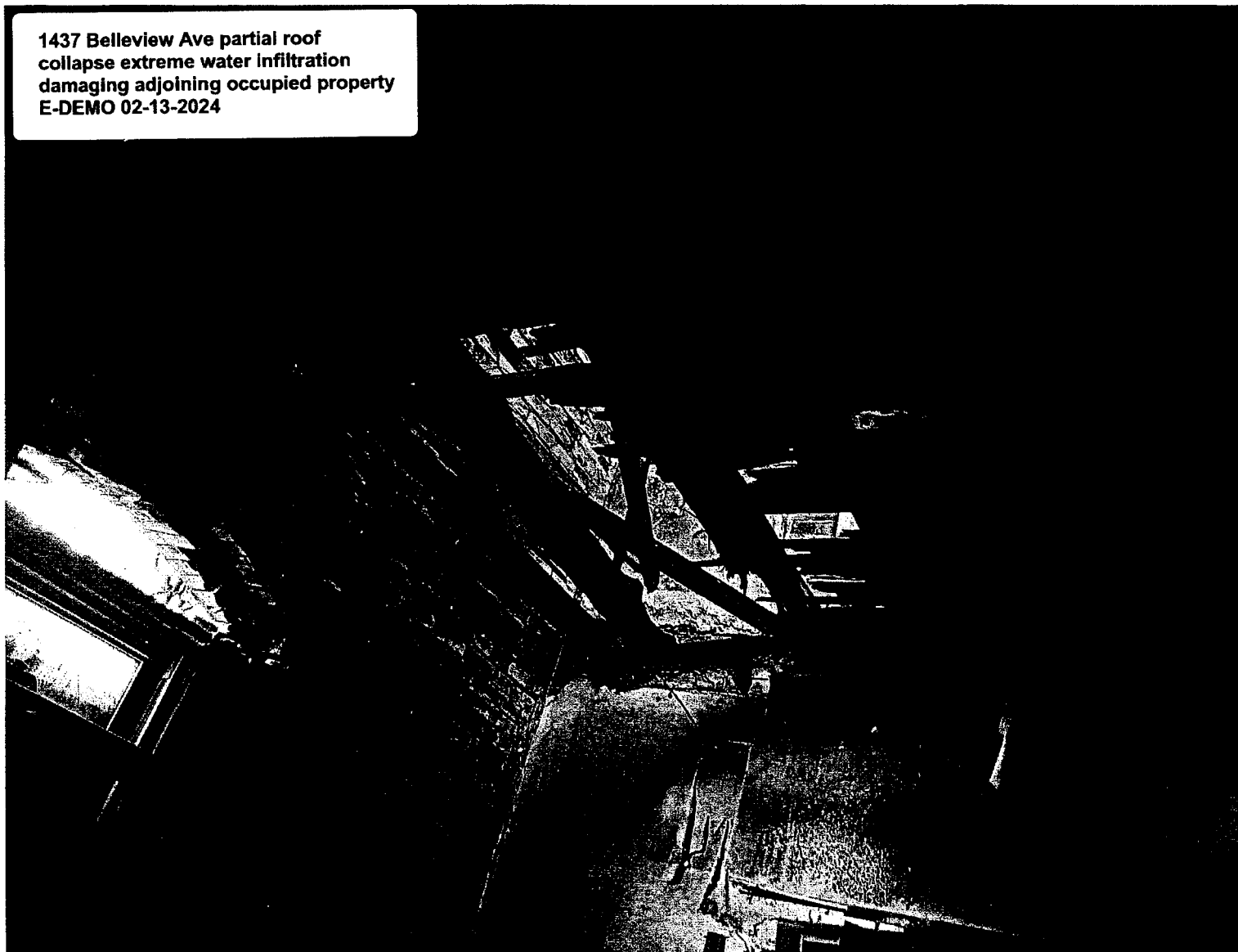



1437 BELLEVIEW AVE PARTIAL ROOF
COLLAPSE EXTREME WATER
INFILTRATION DAMAGING
ADJOINING OCCUPIED PROPERTY E-
DEMO 02-13-2024 JRR

R-25

SE:dh
03-12-24

RESOLUTION AUTHORIZING AND RATIFYING AN EMERGENCY PROCUREMENT AND PAYMENT OF SAME TO THE ORIGINAL W. HARGROVE DEMOLITION CO. FOR THE EMERGENCY DEMOLITION OF 112 N 21ST STREET, BLOCK 1147, LOT 7 AND IMPOSING A MUNICIPAL LIEN AGAINST THE PROPERTY

WHEREAS, on February 16, 2024, the City Construction Official inspected a building which was located at 112 N. 21st Street, Block 1147, Lot 7; and

WHEREAS, upon inspection, the Construction Official determined that the building located at 112 N. 21st Street, Block 1147, Lot 7 was an Unsafe Structure which constituted a danger to the health, safety and welfare of the residents of the City of Camden requiring prompt action; and

WHEREAS, on February 16, 2024, it was determined that the building located at 112 N. 21st Street, Block 1147, Lot 7 required emergency demolition including the removal of all structures, contents, and other debris, whether above or below ground; and the final restoration and grading of the property; and

WHEREAS, the City reached out to The Original W. Hargrove Demolition, Inc., for bid of the emergency demolition of the building located at 112 N. 21st Street, Block 1147, Lot 7 including the removal of all structures, contents, and other debris, whether above or below ground; and the final restoration and grading of the property; and

WHEREAS, the City of Camden received a lump sum bid of EIGHTY-NINE THOUSAND DOLLARS (\$89,000.00) from The Original W. Hargrove Demolition, Inc., for the emergency demolition including the removal of all structures, contents, and other debris, whether above or below ground; and the final restoration and grading of the property at 112 N. 21st Street, Block 1147, Lot 7, Camden, NJ; and

WHEREAS, the City of Camden entered into a contract with The Original W. Hargrove Demolition, Inc. for EIGHTY-NINE THOUSAND DOLLARS (\$89,000.00) for the emergency demolition including the removal of all structures, contents, and other debris, whether above or below ground; the final restoration and grading of 112 N. 21st Street, Block 1147, Lot 7, Camden NJ; and

WHEREAS, pursuant to the directive of the Division of Local Government Services, a certification has been attached hereto which certifies that the funds for this expenditure are available under the budget of the City of Camden, under line item "4-01-E4-605-901", and said certification has been signed by the Chief Financial Officer and approved as to form by the City Attorney; and

WHEREAS, the City of Camden is permitted by New Jersey law, N.J.S.A. 40:48 - 1.1 et seq. and the City of Camden Code to impose a municipal lien in the amount of EIGHTY-NINE THOUSAND DOLLARS (\$89,000.00) on the property located at 112 N. 21st Street, Block 1147, Lot , Camden, NJ or alternatively, to enforce the payment of EIGHTY-NINE THOUSAND DOLLARS (\$89,000.00), together with interest, as a debt of the owner of the property for the City's costs incurred for the emergency demolition, removal of debris, final restoration and grading of 112 N. 21st Street, Block 1147, Lot 7, Camden, NJ; now therefore

BE IT RESOLVED, by the City Council of the City of Camden as follows:

1. The appropriate person in City of Camden shall have the authority to impose and record a lien in the amount of EIGHTY-NINE THOUSAND DOLLARS (\$89,000.00) on the property located at 112 N. 21st Street, Block 1147, Lot 7,

for the costs incurred for the emergency demolition including the removal of debris, final restoration and grading.

2. The municipal lien in the amount of EIGHTY-NINE THOUSAND DOLLARS (\$89,000.00) for the property located at 112 N. 21st Street, Block 1147, Lot 7, Camden, NJ, shall remain on the property until the owner or other interested party satisfies this amount.
3. Interest and other costs shall accrue on the lien amount as allowed by law.
4. The City shall also have the authority pursuant to N.J.S.A. 40:48-1.1 and the Municipal Code of the City of Camden to enforce the payment of the costs incurred by the City in the amount of EIGHTY-NINE THOUSAND DOLLARS (\$89,000.00) for the for the demolition including the removal of debris, final restoration and grading at 112 N. 21st Street, Block 1147, Lot 7, Camden, NJ, together with interest, as a debt of the owner of the property, by instituting an action at law for the collection of this sum.

BE IT FURTHER RESOLVED, that pursuant to N.J.S.A. 52:27BBB-23, a true copy of this Resolution shall be forwarded to the State Commissioner of Community Affairs, who shall have ten (10) days from the receipt thereof to veto this Resolution. All notices of veto shall be filed in the Office of the Municipal Clerk.

Date: March 12, 2024

The above has been reviewed
and approved as to form.



DANIELS. BLACKBURN
City Attorney

ANGEL FUENTES
President, City Council

ATTEST: _____
LUIS PASTORIZA
Municipal Clerk

CITY OF CAMDEN

CERTIFICATION AS TO THE AVAILABILITY OF FUNDS

I CERTIFY, DIRECTOR FOR THE FINANCE DEPARTMENT FOR THE CITY OF CAMDEN, THAT WITH RESPECT TO THE AWARD OF A CONTRACT OR EXPENDITURE OF FUNDS TO: ORIGINAL W. HARGROVE DEMOLITION CO

THAT THE FUNDS ARE AVAILABLE AS OF THE DATE OF THIS RESOLUTION/CERTIFICATION, FROM ONE OF THE FOLLOWING:

- BUDGET APPROPRIATION: 4-01-E4-605-901
AMOUNT \$ 89,000.00

- APPROPRIATION RESERVE:
AMOUNT: \$

- DEDICATED BY RIDER:
AMOUNT: \$

- RESERVE FOR STATE AND FEDERAL GRANT:
AMOUNT \$

- CAPITAL ORDINANCE
AMOUNT: \$

- TRUST ACCOUNT:
AMOUNT: \$

DETERMINATION OF VALUE CERTIFICATION

I CERTIFY, AS CHIEF FINANCIAL OFFICER, THAT THE ANTICIPATED VALUE OF THE CONTRACT, OVER THE FULL LIFE, WILL BE \$ 89,000.00

DESCRIPTION OF THE GOODS AND SERVICES TO BE PROCURED: RESOLUTION AUTHORIZING AND RATIFYING EMERGENCY PROCUREMENT AND PAYMENT OF SAME TO THE ORIGINAL W. HARGROVE DEMOLITION CO, INC FOR 112 N 21ST STREET, BLOCK 1147/LOT 7 AND IMPOSING A MUNICIPAL LIEN AGAINST THE PROPERTY

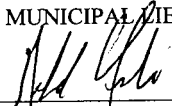

Gerald C. Seneski
Director of Finance

Date: 2/21



CITY OF CAMDEN — CITY COUNCIL ACTION REQUEST FORM

COUNCIL MEETING DATE: 03/12/2024

TO: City Council
FROM: Timothy J. Cunningham, Business Administrator

TITLE OF ORDINANCE/RESOLUTION: RESOLUTION AUTHORIZING AND RATIFYING EMERGENCY PROCUREMENT AND PAYMENT OF SAME TO THE ORIGINAL W HARGROVE DEMOLITION CO, INC, FOR 112 N 21ST STREET, BLOCK 1147/LOT 7 AND IMPOSING A MUNICIPAL LIEN AGAINST THE PROPERTY

Point of Contact:	Lateefah Chandler	Admin-Purchasing	856-757-7475	lachandl@ci.camden.nj.us
	Name	Department-Division-Bureau	Phone	Email

ENDORSEMENTS

Responsible	Recommend Approval (Y/N)	Signature	Date	Comments
Department Director				
Supporting Department Director (if necessary)				
Director of Grants Management				
Qualified Purchasing Agent	Y		2/21	
Director of Finance				
Approved by:			2/22	
Business Administrator		Signature	Date	

Attachments (list and attach all available):

1. Waiver Request Form Attached for State DCA/DLGS Approval - (If applicable)¹
2. Certification of Funds²
3. Addition supporting documents.

"Walk-on" note: All walk-on legislation must be pre-approved by the Business Administrator. The Department Director and Contact Person are jointly responsible for delivering all necessary documents to the City Clerk for distribution at the Council Meeting.

FEB 29 2024

Received by: City Attorney		Signature	Date
----------------------------	--	-----------	------

¹ For Example: Form "A" - Request for approval of Employees Requiring Advice and Consent of Governing Body, Form "D" - Contract Request, Form "E" - Creation/Extension of Services, Form "G" - Grant Approval, Form "H" - Bond Ordinance or Contract Request, Form "I", "Best Price Insurance Contracting" Model Ordinance
² Mandatory for any financial commitment to the City or expenditure of City Funds.

EXECUTIVE SUMMARY

TITLE OF ORDINANCE/RESOLUTION: RESOLUTION AUTHORIZING AND RATIFYING EMERGENCY PROCUREMENT AND PAYMENT OF SAME TO THE ORIGINAL W HARGROVE DEMOLITION CO, INC, FOR 112 N 21ST STREET, BLOCK 1147/LOT 7 AND IMPOSING A MUNICIPAL LIEN AGAINST THE PROPERTY

FACTS/BACKGROUND: (Executive level details. Short concise bullets)

- Ratify the emergency demolition and payment of same to The Original W. Hargrove Demolition Co., Inc., 1507 State Street, Camden NJ 08103 at 112 N 21st Street, Block 1147 Lot 7.
- On 2/16/2024 the Construction Office declared unsafe structure and imminent hazard due to partial roof collapse, actual damage of additional collapse, severe water infiltration and damaging occupied adjoining property
- Received three (3) quotes Hargrove (\$89,000), Winzinger (\$118,000) & Caravella (\$147,000.00)
- The City of Camden Code will impose a municipal lien against this property for the amount of the costs incurred by the City for the demolition and any additional expenses

AMOUNT OF PROPOSED CONTRACT or TOTAL COST OF PROPOSAL: \$89,000.00

PROCUREMENT PROCESS: N.J.S.A. 40A: 11-6 (Emergency)

APPROPRIATION NUMBER: 4-01-E4-605-901

IMPACT STATEMENT:

- ER Demolition work started 02/21/2024

SUBJECT MATTER EXPERTS/ADVOCATES:

- N/A

COORDINATION:

- N/A

Prepared by: LATEEAH CHANDLER

856-757-7159

Name

Phone/Email

**STATE OF NEW JERSEY
DEPARTMENT OF COMMUNITY AFFAIRS
DIVISION OF LOCAL GOVERNMENT SERVICES
CONTRACT REQUEST FORM**

This form must be filled out in its entirety and is intended to provide the Division with appropriate information to determine whether to approve a new or extended service. Please provide any additional information you believe will help the Division make an informed decision.

Municipality	CITY OF CAMDEN
--------------	----------------

Professional Service or EUS Type	N/A
Name of Vendor	THE ORIGINAL W HARGROVE DEMOLITION
Purpose or Need for service:	EMERGENCY DEMOLITION AT 112 N 21 ST STREET, BLOCK 1147, LOT 7
Contract Award Amount	\$89,000.00
Term of Contract	~5 DAYS
Temporary or Seasonal	N/A
Grant Funded (attach appropriate documentation allowing for service through grant funds)	NO
Please explain the procurement process (i.e. bids, RFQ, competitive contracting, etc.)	NJSA 40A:11-6
Were other proposals received? If so, please attach the names and amounts for each proposal received?	YES WINZINGER \$118,000.00 CARAVELLA \$147,000.00

Please attach the RFP, evaluation memoranda or evaluation forms used to evaluate the vendors and a list of all bidders and the bid amounts associated with each bidder.

If the lowest bidder was not selected, please have the appropriate personnel sign the certification on page 2.

	Date _____
Mayor's Signature*	
Business Administrator/Manager Signature	Date _____

*For direct appointments of the Governing Body, Council President or at the discretion of the Director, the most senior member of the Governing Body may sign the waiver in lieu of the Mayor.

The Financial Officer affirms that there is adequate funding available for this action.



Financial Officer Signature

I certify that the vendor selected is in compliance with the adopted Pay to Play Ordinance and that the vendor was notified of any restrictions with respect to campaign contributions.

N/A Date _____
Certifying Officer

For LGS use only:

Approved Denied

Date _____
Director or Designee,
Division of Local Government Services

Number Assigned _____



CITY OF CAMDEN

DEPARTMENT OF CODE ENFORCEMENT

BUILDING BUREAU

EMERGENCY DEMOLITION

To: Keith Walker, Director of Department of Public Works

From: JAMES R RIZZO, Construction Official

Date: Friday, February 16, 2024

SITE: 112 NO 21ST ST

Owner RIVERA DIAZ, FERNANDO
5314 DUFFIELD ST
PHILADELPHIA, PA 19124

I hereby certify that all necessary steps required pursuant to UCC 5:23-2.32 have been taken by the Building Bureau prior to issuing this demolition memorandum for above referenced property.

Please process accordingly.

Signed: _____

JAMES R RIZZO, Construction Official

Signed: _____

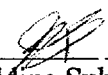
Building Sub code Official

COMMENTS

1 STUCCO WALL

110 NO 21ST ST



NOTICE OF IMMINENT HAZARD

CITY OF CAMDEN
520 MARKET STREET
CAMDEN, NJ 08101
(856)757-7032

Application Date:
Application ID:
Permit Number:
Date Permit Issued:
Notice Date: 2/16/2024
Violation Number: 2024-00380

IDENTIFICATION

Work Site Location: 112 NO 21ST ST
Block: 1147 Lot: 7 Qual:
Owner in Fee: RIVERA DIAZ, FERNANDO
Contractor/Agent:
Address: 5314 DUFFIELD ST
Address:
PHILADELPHIA PA 19124
Telephone:
Telephone:

To: [X] Owner [] Other
[] Contractor/Agent

Date of Inspection: 2/16/2024 Date of Notice: 2/16/2024 Compliance Due Date: 2/21/2024

ACTION

Take NOTICE that as a result of the inspections conducted by this agency on 2/16/2024 of the above property, an imminent hazard has been found to exist pursuant to N.J.S.A. 52:27D-132 and N.J.A.C. 5:23-2.32. The building or structure, or portion thereof, deemed an imminent hazard is described as follows:

PARTIAL ROOF COLLAPSE/ ACTUAL DANGER OF ADDITINAL COLLAPSE, SEVERE WATER INFILTRATION DAMAGING OCCUPIED ADJOINING PROPERTY

As such, you are hereby ORDERED to immediately and forthwith vacate the above structure or portion thereof.

Further, you are ORDERED to:

- [X] Immediately correct the above noticed imminent hazards so as to render the structure temporarily safe and secure.
[X] Demolish the above structure by 2/21/2024.

Failure to immediately comply with this ORDER may result in the necessary correction being made by the Construction Official at the expense of the property owner pursuant to N.J.A.C. 5:23-2.32(b)5.

Failure to render the structure temporarily safe and secure and/or demolish the structure in accordance with this ORDER will result in this matter being forwarded to legal counsel for prosecution, and assessment of penalties up to \$2,000.00 per week per violation. You must immediately declare to the Construction Official, your acceptance or rejection of the terms of this ORDER.

If you wish to contest this ORDER, you must apply for a stay to a court of competent jurisdiction within 24 hours.

If you have any questions concerning this matter, please call: (856) 757-7032.

By Order of: [Signature]
CITY OF CAMDEN Construction Official

Date: 2/16/24

Sent by Certified Mail:

PUBLIC SERVICE ELECTRIC & GAS COMPANY
PO BOX 1023,
CRANFORD, NJ 07016-1023
Phone: 800-817-3366 Fax: 908-497-1878
E-mail: demolition@pseg.com

**WILL BE
DEMOLISHED
2/21/24**

PSE&G SERVICE REMOVAL REQUEST FORM

Office Use Only: Project # _____ G1# _____ E1# _____

REVIEW APPLICATION INSTRUCTIONS BEFORE COMPLETING

COMPANY NAME *if applicable*: CITY OF CAMDEN

OWNER'S NAME: RIVERA, DIAAZ, FERNANDO

OWNER'S AUTHORIZED AGENT name and title: N/A

SERVICE ADDRESS: 112 NO 21ST ST TOWN: CAMDEN
(OF BLDG TO BE DEMOLISHED)

CROSS STREET: HIGH

OWNER'S MAILING ADDRESS 5314 DUFFIELD ST, PHILADELPHIS, PA 19124

(This is where the service removal completion letter will be sent)

OWNERS'S PRIMARY RESIDENCE? (CIRCLE ONE) YES (NO)

PREMISE VACANT? (CIRCLE ONE) (YES) NO

IMPORTANT: APPLICATION WILL NOT BE ACCEPTED UNTIL APPLICANT HAS TAKEN OWNERSHIP AND PROPERTY IS VACANT.

PROJECT CONTACT: JAMES R RIZZO FAX: JARIZZO@CI.CAMDEN.NJ.US

PRIMARY PHONE: 609-319-9883 (OR E-MAIL) ALTERNATE PHONE: N/A

METER NUMBERS: Gas N/A Electric N/A

TYPE AND NUMBER OF STRUCTURES TO BE DEMOLISHED: N/A

DOES THE STRUCTURE TO BE DEMOLISHED HAVE MORE THAN ONE ADDRESS? **A separate form is required for each address.**

PSE&G LIGHTING TO BE REMOVED? (CIRCLE ONE) YES (NO)

PSE&G POLES TO BE REMOVED? (CIRCLE ONE) YES (NO)

POLE#(S) **required**: _____

OTHER PSE&G EQUIPMENT?(TRANSFORMER, SWITCHGEAR, ETC.) YES NO

TYPE OF ELECTRICAL SERVICE: (CIRCLE ONE) (OVERHEAD) UNDERGROUND

ARE YOU AWARE OF ANY ENVIRONMENTAL ISSUES AT THIS SITE? YES NO

PLEASE EXPLAIN _____

TYPE OF STRUCTURE TO BE BUILT AFTER DEMOLITION: N/A

APPROXIMATE DATE OF RECONSTRUCTION: N/A

SIGNATURE:  PRINT NAME: JAMES R RIZZO

DATE: 02/16/2024

BY SUBMITTING THIS APPLICATION YOU ARE CERTIFYING THAT YOU ARE AUTHORIZED TO REQUEST REMOVAL OF ELECTRIC AND GAS SERVICES AT THE PROPERTY SPECIFIED AND THAT PREMISE IS VACANT. Proof of ownership required at time of application. Please refer to the instructions sent with this form for list of acceptable forms of proof.

112 NO 21ST ST
PARTIAL ROOF COLLAPSE
ACTUAL DANGER OF ADDITIONAL COLLAPSE
SEVERE WATER INFILTRATION DAMAGING
OCCUPIED ADJOINING PROPERTY6
02-16-2024 E-DEMO JRR

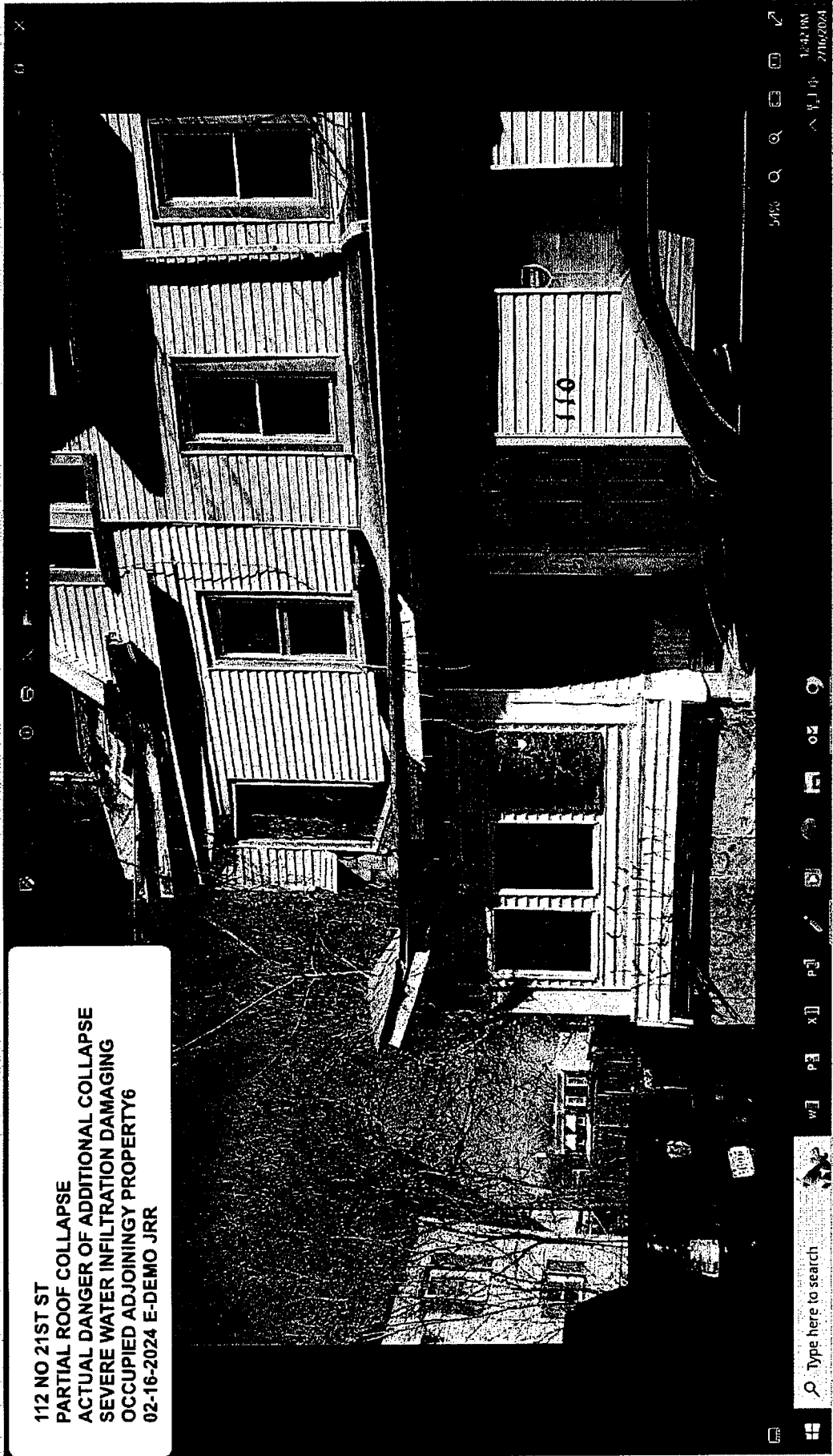

Type here to search

1:42 PM
2/16/2024

112 NO 21ST ST
PARTIAL ROOF COLLAPSE
ACTUAL DANGER OF ADDITIONAL COLLAPSE
SEVERE WATER INFILTRATION DAMAGING
OCCUPIED ADJOINING PROPERTY
02-16-2024 E-DEMO JRR

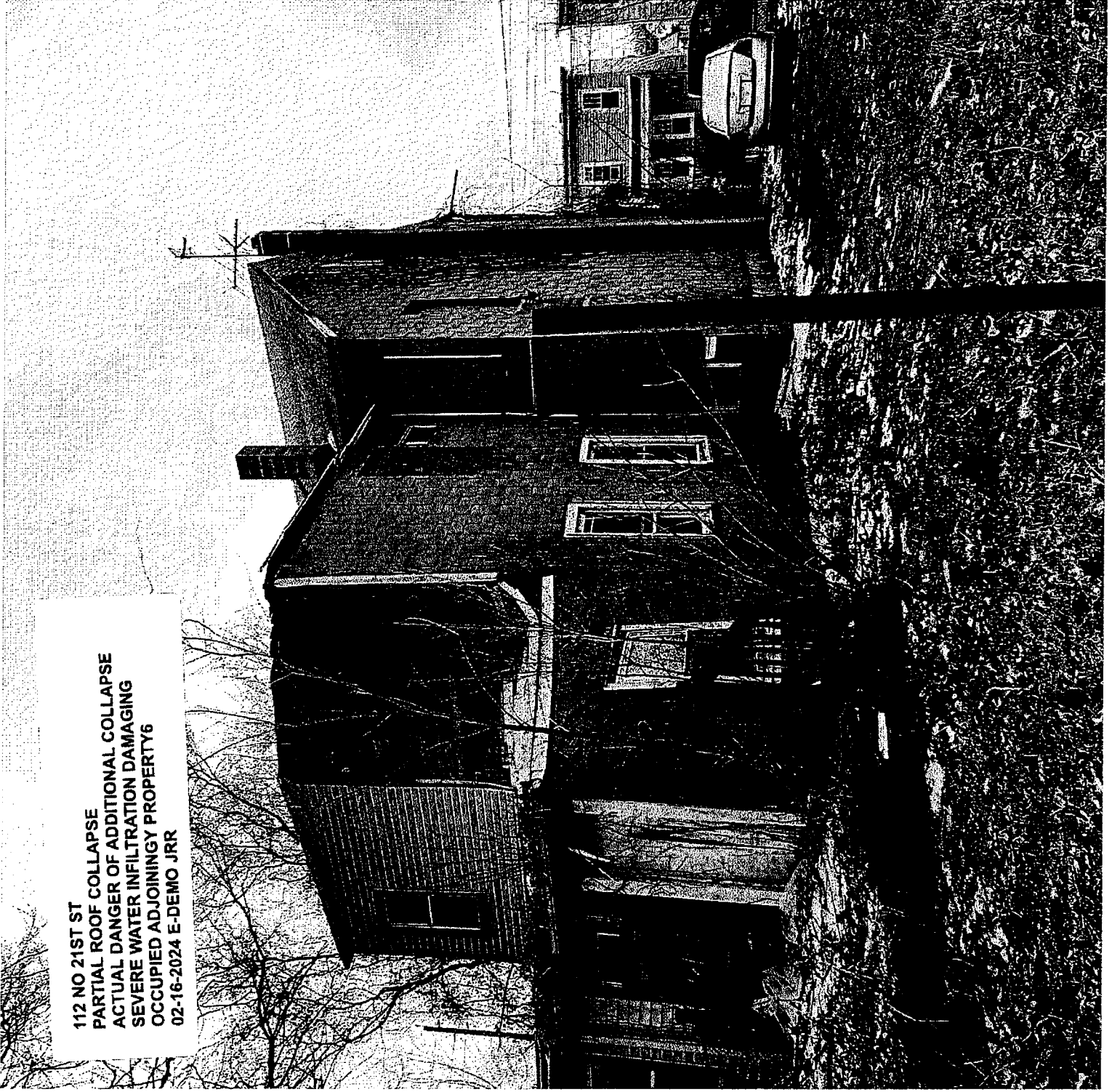

112 NO 21ST ST
PARTIAL ROOF COLLAPSE
ACTUAL DANGER OF ADDITIONAL COLLAPSE
SEVERE WATER INFILTRATION DAMAGING
OCCUPIED ADJOINING PROPERTY6
02-16-2024 E-DEMO JRR

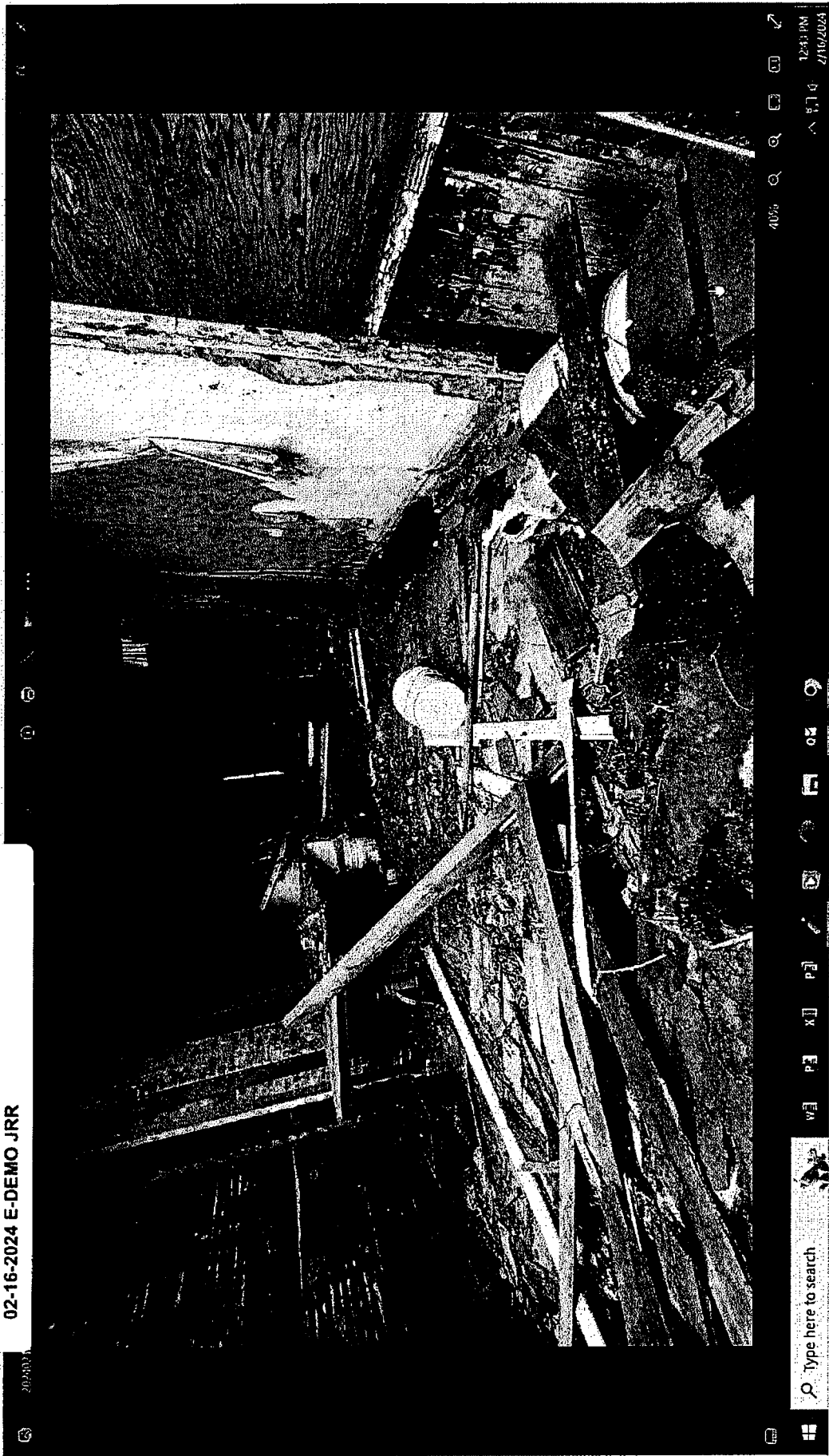

Type here to search

12:43 PM
2/16/2024

CITY OF CAMDEN

EMERGENCY CONTRACT TO PROVIDE FOR THE DEMOLITION OF A RESIDENTIAL PROPERTY, THE REMOVAL OF ALL STRUCTURES, CONTENTS AND ALL OTHER DEBRIS, WHETHER ABOVE OR BELOW GROUND, AT 112 NORTH 21ST STREET, BLOCK 1147, LOT 7, FINAL RESTORATION AND GRADING OF THIS PROPERTY AND STUCCO OF ADJOINING WALL AT 110 NORTH 21ST STREET IN THE CITY OF CAMDEN

This Emergency Demolition is encompassed by the Standard City Demolition Specifications, which are incorporated by reference and made a part hereto, and the following, special provisions.

On February 16, 2024, the City of Camden Construction Official conducted an inspection of the structure at 112 North 21st Street, Block 1147, Lot 7, and determined that it is an unsafe structure and imminent hazard: partial roof collapse, acutal damage of additional collapse, severe water infiltration and damaging occupied adjoining property. These unsafe conditions make this structure extremely dangerous to the residents. The Construction Official provided the owner until February 21, 2024 to demolish the structure or correct the unsafe conditions. The owner has failed to do so and the Construction Official has determined that the building structure must be promptly demolished.

By this emergency quote, the City of Camden is seeking one (1) contractor to provide for the demolition of the residential property at 112 North 21st Street, Block 1147, Lot 7, the removal of all structures, contents and all other debris, whether above or below ground, and final restoration and grading of the property and stucco of adjoining wall at 110 North 21st Street in the City of Camden.

The Contractor must respond by no later than 10:00 am on February 20, 2024. The Purchasing Bureau will contact the successful vendor by telephone/email with notice to proceed.

Contractor must secure the property immediately after being notified of the award on February 20, 2024 for public safety. A Portable six-foot (6') metal cyclone fence (**hard fencing**) must be erected around the pedestrian walkway(s) of the structure(s) to be demolished. **(NO EXCEPTIONS). Any immediate hazards [falling debris, etc.] that has the potential to fall outside of the fencing must be corrected at that time. Contractor must begin demolition by 8:00 am on Wednesday, February 21, 2024.**

Contractor shall ensure that dust be kept to a minimum by spraying the site with water during the demolition. Sidewalks should be made passable and left broom clean daily during the course of your demolition operations.

All Contractor signage shall be removed from the worksite at the time the job is completed. This requirement is a condition prior to receipt of final payment.

PLEASE BE ADVISED

- **EMERGENCY CONTRACT TO PROVIDE FOR THE DEMOLITION OF A RESIDENTIAL PROPERTY, THE REMOVAL OF ALL STRUCTURES, CONTENTS AND ALL OTHER DEBRIS, WHETHER ABOVE OR BELOW GROUND, AT 112 NORTH 21ST STREET, BLOCK 1147, LOT 7, FINAL RESTORATION AND GRADING OF THIS PROPERTY AND STUCCO OF ADJOINING WALL AT 110 NORTH 21ST STREET IN THE CITY OF CAMDEN**
- **Any tanks or containers on the property must be removed from the property and such removal costs shall be included in the bid price sheet. All such removal work shall be done in accordance with and comply with all applicable federal, state, and local laws, ordinances, rules and regulations. Furthermore, the Contractor must comply with the New Jersey Department of Labor procedures, rules, and regulations, including providing appropriate documents, affidavits and/or certifications.**
- **Contractor must secure subject site with sufficient and appropriate security fencing while the Contractor is performing the emergency demolition in order to adequately protect the public health, safety and welfare of the citizens of the City.**
- **All costs for asbestos and tank and/or container removals must be included in the Bid Price Sheet's Lump Sum Payments. The City of Camden will not pay any additional costs for these removals.**
- **AWARD WILL BE BASED ON THE TOTAL AMOUNT OF THE QUOTE.**

***EXCEPTION:** If asbestos or other contamination is verified, then the demolition time schedule is referred to the Construction Official.

A Certificate of Environmental Compliance and Hold Harmless Agreement issued by the City Construction Official are attached to this fax; they must be completed and returned with the Proposal prior to any award and demolition work. Return of the Certificates is MANDATORY; otherwise said proposal will be rejected. The worksite must remain secure until project is properly abated.

The dollar amount for all demolition quotes must be submitted in two written versions as per example.

Example: “Seven thousand five hundred dollars” and \$ 7,500.00

PLEASE NOTE: In the event of a tie for emergency demolition request, the determining factor will be awarded to the contractor who submits their proposal the earliest

BID PRICE SHEET

EMERGENCY CONTRACT TO PROVIDE FOR THE DEMOLITION OF A RESIDENTIAL PROPERTY, THE REMOVAL OF ALL STRUCTURES, CONTENTS AND ALL OTHER DEBRIS, WHETHER ABOVE OR BELOW GROUND, AT 112 NORTH 21ST STREET, BLOCK 1147, LOT 7, FINAL RESTORATION AND GRADING OF THIS PROPERTY AND STUCCO OF ADJOINING WALL AT 110 NORTH 21ST STREET IN THE CITY OF CAMDEN

\$ _____
TOTAL

Total Bid Amount in Words: _____

NOTE: THE ABOVE LUMP SUM PAYMENTS MUST INCLUDE ALL COSTS, INCLUDING REMOVAL OF ALL DEBRIS, WHETHER ABOVE OR BELOW GROUND, ASBESTOS ABATEMENT, REMOVAL OF ABOVE GROUND OIL, PROPANE OR OTHER TYPES OF TANKS OR CONTAINERS, INCLUDING ABOVE GROUND OIL, PROPANE OR OTHER TYPES OF TANKS OR CONTAINERS LOCATED IN THE BASEMENT OF THE STRUCTURE(S) TO BE DEMOLISHED, ALL RESTORATION AND GRADING COSTS AND ALL OTHER COSTS.

PLEASE NOTE: GAS AND ELECTRIC SERVICES TO 112 NORTH 21ST STREET, BLOCK 1147, LOT 7, CAMDEN, NEW JERSEY HAVE BEEN DISCONNECTED BY PSE&G.

THE ABOVE LUMP SUM PAYMENTS MUST INCLUDE ALL COSTS ASSOCIATED WITH OTHER DISCONNECTION COSTS AS WELL AS DISCONNECTION OF APPURTENANT EQUIPMENT SUCH AS METERS, REGULATORS, AND GAUGES AND THE COORDINATION AND SCHEDULING THEREOF.

PLEASE NOTE: THE BIDDER WILL NOT BE RESPONSIBLE FOR WATER AND SEWER DISCONNECTS OR FOR THE COSTS FOR THESE WATER AND SEWER DISCONNECTS SINCE THE WATER AND SEWER DISCONNECT SERVICES ARE TO BE PROVIDED BY AMERICAN WATER.

Fees for any additional charges not listed in this bid sheet are expressly not permitted under the contract.

I **HEREBY** submit and confirm this Bid Price Sheet, subject to all requirements and conditions stated in these bid specifications.

Company Name: _____

Bidder's Corporate Officer's Signature: _____

print name) Name : _____ (

(print title) Title: _____

Date: _____



CERTIFICATE OF ENVIRONMENTAL COMPLIANCE

Name of Contractor: _____

I, _____, hereby agree to hold harmless the City of Camden, its successors and assignees, or its officials, officers, employees and agents, for any injuries to person or property incurred on losses suffered on account of the demolition of

I certify upon inspection of the property that there is no asbestos or visible hazardous tanks. The contractor will not be responsible for the removal of subsurface tanks unless otherwise noted by the City of Camden. If either of these items are identified, they will be removed in accordance with applicable federal, state, and local laws, ordinances, rules and regulations. Including, the New Jersey Department of Labor procedures, rules, and regulations, including providing appropriate documents, affidavits and/or certifications and also N.J.S.A 52:27D – 119 et. Seq.

Asbestos		Tanks	
Yes	No	Yes	No
_____	_____	_____	_____

By: _____

Sworn and subscribed to before me

On this _____ day of _____ 2024

NOTARY PUBLIC

**RESOLUTION AUTHORIZING AND RATIFYING EMERGENCY PROCUREMENT
AND PAYMENT OF SAME TO WINZINGER, INC., FOR 246-252 LINE STREET,
BLOCK 226, LOT 28 AND IMPOSING A MUNICIPAL LIEN AGAINST THE
PROPERTY**

WHEREAS, after a fire on December 18, 2023, the Construction Official of the City inspected the building located at 246-252 Line Street, Block 226, Lot 28; and

WHEREAS, upon inspection, the Construction Official determined that the building at 246-252 Line Street, Block 226, Lot 28, was an Unsafe Structure and imminent hazard, which constituted a danger to the health, safety and welfare of the residents of the City of Camden and required prompt action; and

WHEREAS, the Construction Official gave the owner until December 19, 2023 to demolish the building at 246-252 Line Street, Block 226, Lot 28 (Site), which the owner failed to do so; and

WHEREAS, three (3) quotes were received from contractors for the demolition including the removal of all structures, contents, and debris, whether above or below ground; and the final restoration and grading of the Site; and

WHEREAS, the City of Camden received a quote of ONE HUNDRED THIRTEEN THOUSAND DOLLARS (\$113,000.00) from Winzinger, Inc., the lowest quote, for the demolition including the removal of all structures, contents, and debris, whether above or below ground; and the final restoration and grading of the Site; and

WHEREAS, on December 18th and 19th, 2023, respectively, Winzinger assisted the City of Camden Fire Department by providing excavation services, in the amount of SIX THOUSAND SIX HUNDRED SEVENTEEN DOLLARS AND SIXTY-EIGHT CENTS (\$6,617.68), at the Site; and

WHEREAS, the City of Camden entered into a contract with Winzinger, Inc., for an amount not to exceed ONE HUNDRED NINETEEN THOUSAND SIX HUNDRED SEVENTEEN DOLLARS AND SIXTY-EIGHT CENTS (\$119,617.68) for the demolition including the removal of all structures, contents and debris, whether above or below ground; and the final restoration and grading of the property and for the excavation services that were provided to the City's Fire Department on December 18th and 19th, respectively; and

WHEREAS, pursuant to the directive of the Division of Local Government Services, a certification has been attached hereto which certifies that the funds for this expenditure are available and appropriated for in the budget of the City of Camden, under line item "4-01-E4-605-901", and said certification has been signed by the Chief Financial Officer and approved as to form by the City Attorney; and

WHEREAS, the City of Camden is permitted by New Jersey law, N.J.S.A. 40:48 - 1.1 et seq. and the City of Camden Code to impose a municipal lien in the amount of ONE HUNDRED NINETEEN THOUSAND SIX HUNDRED SEVENTEEN DOLLARS AND SIXTY-EIGHT CENTS (\$119,617.68) on the property at 246-252 Line Street, Block 226, Lot 28, or alternatively, to enforce the payment of ONE HUNDRED NINETEEN THOUSAND SIX HUNDRED SEVENTEEN DOLLARS AND SIXTY-EIGHT CENTS (\$119,617.68), together with interest, as a debt of the owner of the property for the City's costs incurred for the contractor to perform the work for the removal of demolition debris at the property; now, therefore

BE IT RESOLVED, by the City Council of the City of Camden as follows:

1. The appropriate person in City of Camden shall have the authority to impose and record a lien in the amount of ONE HUNDRED NINETEEN THOUSAND SIX HUNDRED SEVENTEEN DOLLARS AND SIXTY-EIGHT CENTS (\$119,617.68) on the property at 246-252 Line Street, Block 226, Lot 28, for the costs incurred for the demolition, removal of debris and final restoration and grading from the Site.
2. The municipal lien in the amount of ONE HUNDRED NINETEEN THOUSAND SIX HUNDRED SEVENTEEN DOLLARS AND SIXTY-EIGHT CENTS (\$119,617.68) for the property at 246-252 Line Street, Block 226, Lot 28, shall remain on the property until the owner or other interested party satisfies this amount.
3. Interest and other costs shall accrue on the lien amount as allowed by law.
4. The City shall also have the authority pursuant to N.J.S.A. 40:48-1.1 and the Camden City Code to enforce the payment of the costs incurred by the City in the amount of ONE HUNDRED NINETEEN THOUSAND SIX HUNDRED SEVENTEEN DOLLARS AND SIXTY-EIGHT CENTS (\$119,617.68) for the demolition removal of debris of the property at 246-252 Line Street, Block 226, Lot 28, together with interest, as a debt of the owner of the property, by instituting an action at law for the collection of this sum.

BE IT FURTHER RESOLVED, that pursuant to N.J.S.A. 52:27BBB-23, a true copy of this Resolution shall be forwarded to the State Commissioner of Community Affairs, who shall have ten (10) days from the receipt thereof to veto this Resolution. All notices of veto shall be filed in the Office of the Municipal Clerk.

Date: March 12, 2024

The above has been reviewed
and approved as to form.



DANIEL S. BLACKBURN
City Attorney

ANGEL FUENTES
President, City Council

ATTEST:

LUIS PASTORIZA
Municipal Clerk

CITY OF CAMDEN

CERTIFICATION AS TO THE AVAILABILITY OF FUNDS

I CERTIFY, DIRECTOR FOR THE FINANCE DEPARTMENT FOR THE CITY OF CAMDEN, THAT WITH RESPECT TO THE AWARD OF A CONTRACT OR EXPENDITURE OF FUNDS TO: WINZINGER

THAT THE FUNDS ARE AVAILABLE AS OF THE DATE OF THIS RESOLUTION/CERTIFICATION, FROM ONE OF THE FOLLOWING:

• BUDGET APPROPRIATION: 4-01-E4-605-901
AMOUNT \$ 119,617.68

APPROPRIATION RESERVE:
AMOUNT: \$

• DEDICATED BY RIDER:
AMOUNT: \$

• RESERVE FOR STATE AND FEDERAL GRANT:
AMOUNT \$

• CAPITAL ORDINANCE
AMOUNT: \$

• TRUST ACCOUNT:
AMOUNT: \$

DETERMINATION OF VALUE CERTIFICATION

I CERTIFY, AS CHIEF FINANCIAL OFFICER, THAT THE ANTICIPATED VALUE OF THE CONTRACT, OVER THE FULL LIFE, WILL BE \$ 119,617.68

DESCRIPTION OF THE GOODS AND SERVICES TO BE PROCURED: RESOLUTION AUTHORIZING AND RATIFYING EMERGENCY PROCUREMENT AND PAYMENT OF SAME TO WINZINGER ,INC FOR 246-252 LINE STREET BLOCK 226/LOT 28 AND IMPOSING A MUNICIPAL LIEN AGAINST THE PROPERTY

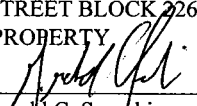

Gerald C. Seneski

Director of Finance

Date: 2/21



CITY OF CAMDEN — CITY COUNCIL ACTION REQUEST FORM

COUNCIL MEETING DATE: 03/12/2024

TO: City Council
FROM: Timothy J. Cunningham, Business Administrator

TITLE OF ORDINANCE/RESOLUTION: RESOLUTION AUTHORIZING AND RATIFYING EMERGENCY PROCUREMENT AND PAYMENT OF SAME TO WINZINGER, INC FOR 246-252 LINE STREET, BLOCK 226/LOT 28) AND IMPOSING A MUNICIPAL LIEN AGAINST THE PROPERTY

Point of Contact: Lateefah Chandler
Admin-Purchasing 856-757-7475 lachandl@ci.camden.nj.us
Name Department-Division-Bureau Phone Email

ENDORSEMENTS

Table with 5 columns: Recommend Approval (Y/N), Signature, Date, Comments. Includes handwritten signature and date 2/21.

Approved by: Business Administrator
Signature
Date

Attachments (list and attach all available):
1. Waiver Request Form Attached for State DCA/DLGS Approval - (If applicable)1
2. Certification of Funds2
3. Addition supporting documents.
"Walk-on" note: All walk-on legislation must be pre-approved by the Business Administrator. The Department Director and Contact Person are jointly responsible for delivering all necessary documents to the City Clerk for distribution at the Council Meeting.

Received by: City Attorney
Signature
Date FEB 29 2024

1 For Example: Form "A" - Request for approval of Employees Requiring Advice and Consent of Governing Body, Form "D" - Contract Request, Form "E" - Creation/Extension of Services, Form "G" - Grant Approval, Form "H" - Bond Ordinance or Contract Request, Form "I", "Best Price Insurance Contracting" Model Ordinance
2 Mandatory for any financial commitment to the City or expenditure of City Funds.

EXECUTIVE SUMMARY

TITLE OF ORDINANCE/RESOLUTION: RESOLUTION AUTHORIZING AND RATIFYING EMERGENCY PROCUREMENT AND PAYMENT OF SAME TO WINZINGER, INC FOR 246-252 LINE STREET, BLOCK 226/LOT 28) AND IMPOSING A MUNICIPAL LIEN AGAINST THE PROPERTY

FACTS/BACKGROUND: (Executive level details. Short concise bullets)

- Ratify the emergency demolition and payment of same to Winzinger Inc, 1704 Marne Highway, Hainesport, NJ 08036 at 246-252 Line Street, Block 226, Lot 28.
- On 12/18/2023 the Construction Office declared unsafe structure and imminent hazard due to major fire
- Received three (3) quotes Hargrove (\$279,000), Winzinger (\$113,000) & Caravella (\$188,999)
- Winzinger also providing excavator services to assist Camden Fire Department on Dec 18 & 19 for \$6,617.68 at the Broadway Family Center, location of fire
- The City of Camden Code will impose a municipal lien against this property for the amount of the costs incurred by the City for the demolition and any associated expenses (excavator)

AMOUNT OF PROPOSED CONTRACT or TOTAL COST OF PROPOSAL: \$119,617.68

PROCUREMENT PROCESS: N.J.S.A. 40A: 11-6 (Emergency)

APPROPRIATION NUMBER: 4-01-E4-605-901

IMPACT STATEMENT:

- ER Demolition work started 12/19/2023

SUBJECT MATTER EXPERTS/ADVOCATES:

- N/A

COORDINATION:

- N/A

Prepared by: LATEEAH CHANDLER

856-757-7159

Name

Phone/Email

**STATE OF NEW JERSEY
DEPARTMENT OF COMMUNITY AFFAIRS
DIVISION OF LOCAL GOVERNMENT SERVICES
CONTRACT REQUEST FORM**

This form must be filled out in its entirety and is intended to provide the Division with appropriate information to determine whether to approve a new or extended service. Please provide any additional information you believe will help the Division make an informed decision.

Municipality	CITY OF CAMDEN
Professional Service or EUS Type	N/A
Name of Vendor	WINZINGER INC
Purpose or Need for service:	EMERGENCY DEMOLITION AT 246-252 LINE STREET, BLOCK 226, LOT 28
Contract Award Amount	\$119,617.68
Term of Contract	~5 DAYS
Temporary or Seasonal	N/A
Grant Funded (attach appropriate documentation allowing for service through grant funds)	NO
Please explain the procurement process (i.e. bids, RFQ, competitive contracting, etc.)	NJSA 40A:11-6
Were other proposals received? If so, please attach the names and amounts for each proposal received?	YES HARGROVE \$279,000.00 CARAVELLA \$188,999.00

Please attach the RFP, evaluation memoranda or evaluation forms used to evaluate the vendors and a list of all bidders and the bid amounts associated with each bidder.

If the lowest bidder was not selected, please have the appropriate personnel sign the certification on page 2.

Mayor's Signature*

Date

Business Administrator/Manager Signature

Date

*For direct appointments of the Governing Body, Council President or at the discretion of the Director, the most senior member of the Governing Body may sign the waiver in lieu of the Mayor.

The Financial Officer affirms that there is adequate funding available for this action.

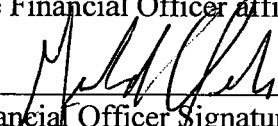

Financial Officer Signature

I certify that the vendor selected is in compliance with the adopted Pay to Play Ordinance and that the vendor was notified of any restrictions with respect to campaign contributions.

N/A Date _____
Certifying Officer

For LGS use only:

Approved Denied _____

Date _____
Director or Designee,
Division of Local Government Services

Number Assigned _____



CITY OF CAMDEN

DEPARTMENT OF CODE ENFORCEMENT

BUILDING BUREAU

EMERGENCY DEMOLITION

To: Keith Walker, Director of Department of Public Works

From: JAMES R RIZZO, Construction Official

Date: Monday, December 18, 2023

SITE: 246-252 LINE ST

Owner BROADWAY FAMILY CENTER, INC
Address 250 LINE ST
CAMDEN, NJ 08103

I hereby certify that all necessary steps required pursuant to UCC 5:23-2.32 have been taken by the Building Bureau prior to issuing this demolition memorandum for above referenced property.

Please process accordingly.

Signed: _____
JAMES R RIZZO, Construction Official

Signed: _____
Building Sub code Official

COMMENTS — NO STUCCO



CITY OF CAMDEN
 520 MARKET STREET
 CAMDEN, NJ 08101
 (856)757-7032

NOTICE OF IMMINENT HAZARD

Application Date:
 Application ID:
 Permit Number:
 Date Permit Issued:
 Notice Date: 12/18/2023
 Violation Number: 2023-03564

IDENTIFICATION

Work Site Location: 246-252 LINE ST Block: 226 Lot: 28 Qual: _____
 Owner in Fee: BROADWAY FAMILY CENTER, INC Contractor/Agent: _____
 Address: 259 LINE ST Address: _____
CAMDEN NJ 08103 Telephone: _____
 Telephone: _____

To: Owner Other
 Contractor/Agent

Date of Inspection: 12/18/2023 Date of Notice: 12/18/2023 Compliance Due Date: 12/19/2023

ACTION

Take NOTICE that as a result of the inspections conducted by this agency on 12/18/2023 of the above property, an imminent hazard has been found to exist pursuant to N.J.S.A. 52:27D-132 and N.J.A.C. 5:23-2.32. The building or structure, or portion thereof, deemed an imminent hazard is described as follows:

MAJOR FIRE

As such, you are hereby **ORDERED** to immediately and forthwith vacate the above structure or portion thereof.

Further, you are **ORDERED** to:

- Immediately correct the above noticed imminent hazards so as to render the structure temporarily safe and secure.
- Demolish the above structure by 12/19/2023.

Failure to immediately comply with this **ORDER** may result in the necessary correction being made by the Construction Official at the expense of the property owner pursuant to N.J.A.C. 5:23-2.32(b)5.

Failure to render the structure temporarily safe and secure and/or demolish the structure in accordance with this **ORDER** will result in this matter being forwarded to legal counsel for prosecution, and assessment of penalties up to \$2,000.00 per week per violation. You must immediately declare to the Construction Official, your acceptance or rejection of the terms of this **ORDER**.

If you wish to contest this **ORDER**, you must apply for a stay to a court of competent jurisdiction within 24 hours.

If you have any questions concerning this matter, please call: (856) 757-7032.

By Order of: [Signature] Date: 12/18/23
 CITY OF CAMDEN Construction Official

Sent by Certified Mail: _____

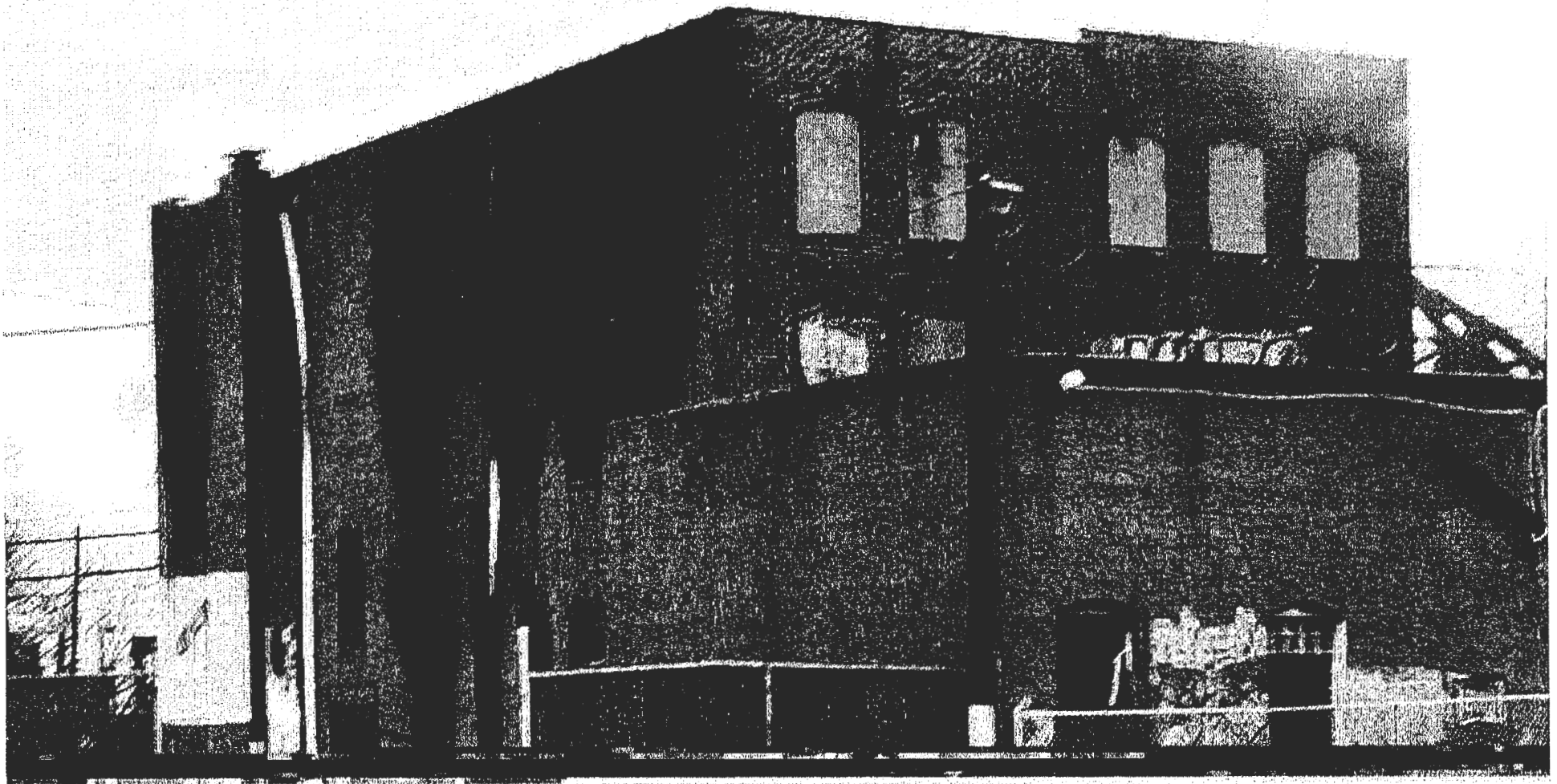

**EMERGENCY DEMOLITION
246-252 LINE ST, CAMDEN
DECEMBER 18, 2023**

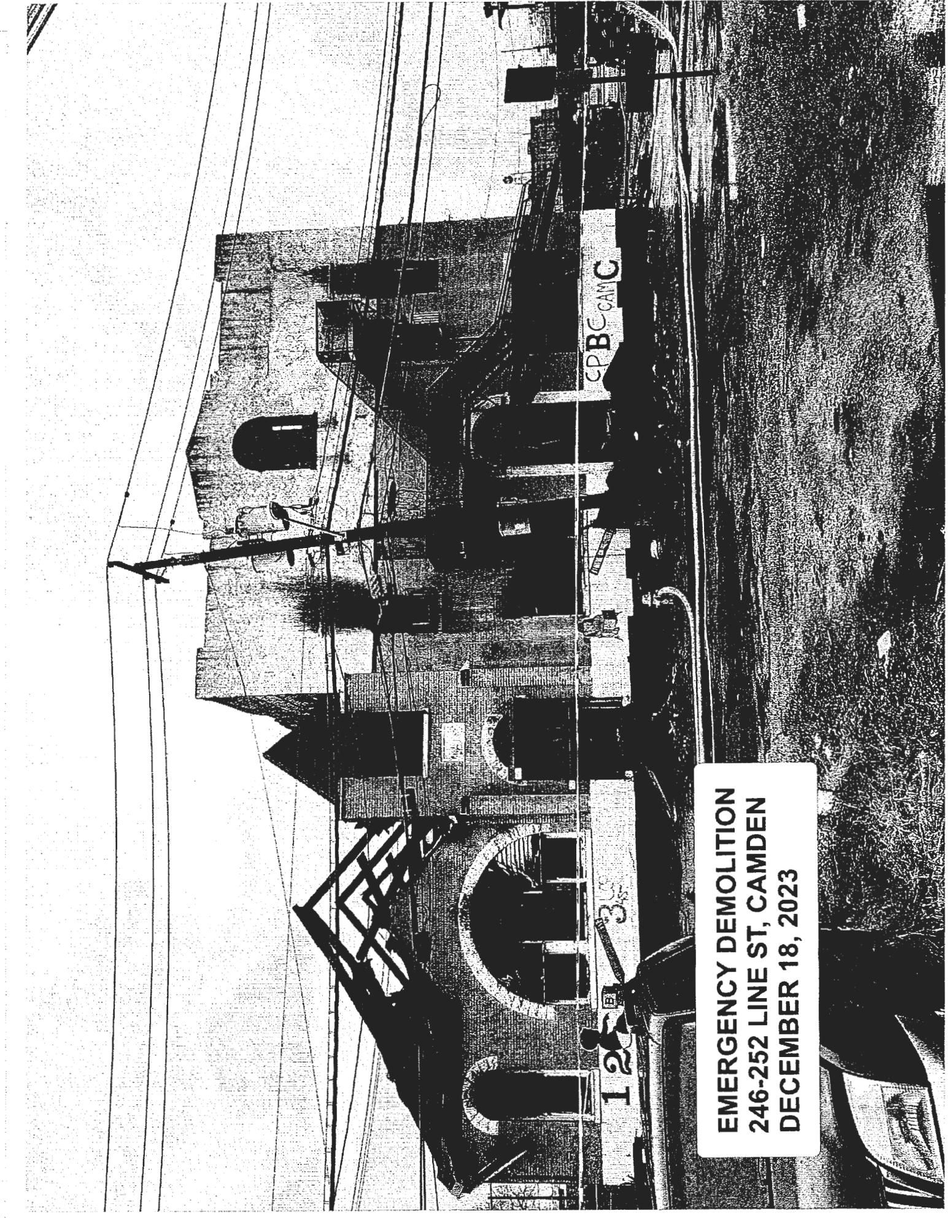

**EMERGENCY DEMOLITION
246-252 LINE ST, CAMDEN
DECEMBER 18, 2023**

CPBC CAMC

1233



**EMERGENCY DEMOLITION
246-252 LINE ST, CAMDEN
DECEMBER 18, 2023**

**EMERGENCY DEMOLITION
246-252 LINE ST, CAMDEN
DECEMBER 18, 2023**



**EMERGENCY DEMOLITION
246-252 LINE ST, CAMDEN
DECEMBER 18, 2023**

125

3

CPBC
CAMC

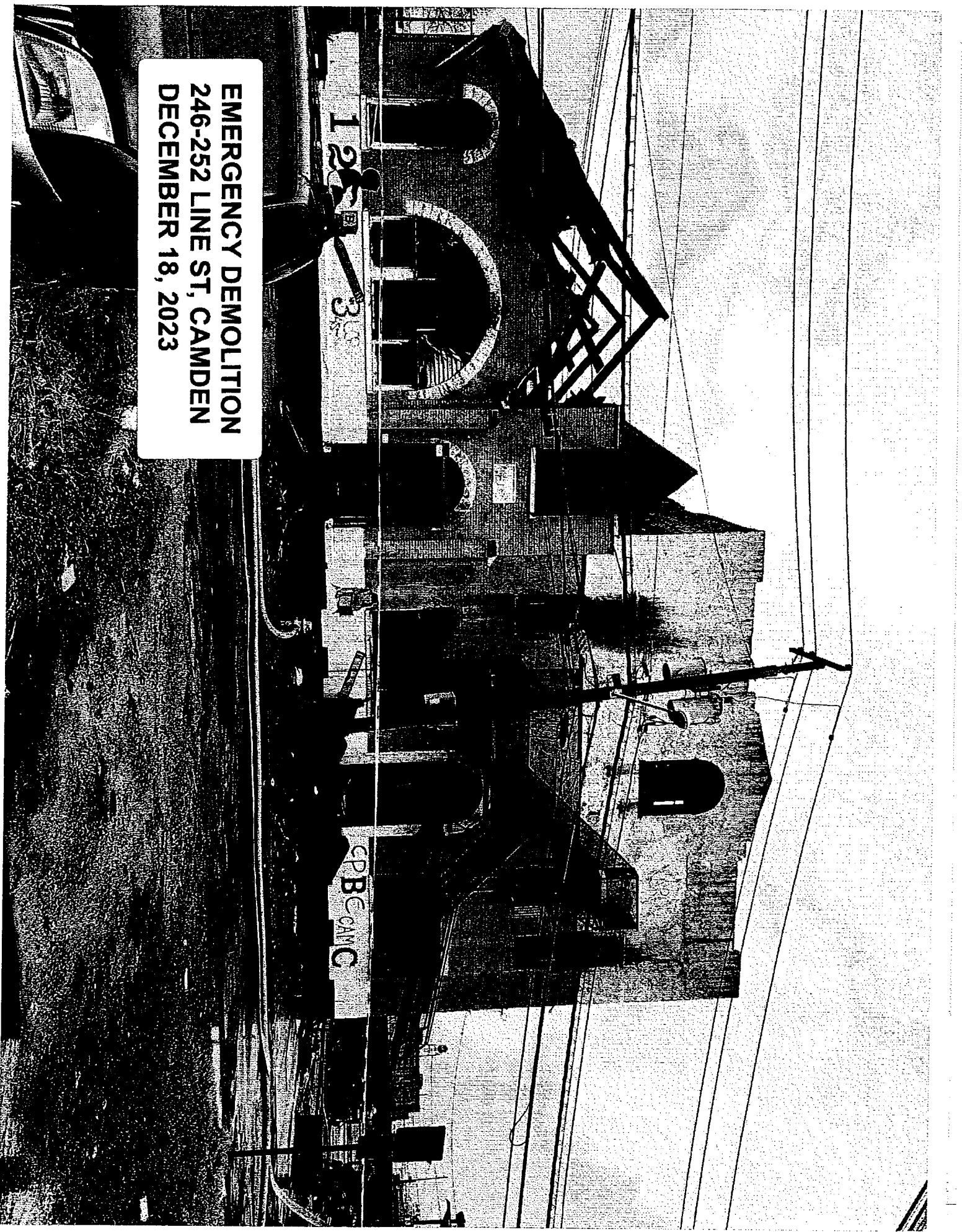

**EMERGENCY DEMOLITION
246-252 LINE ST, CAMDEN
DECEMBER 18, 2023**

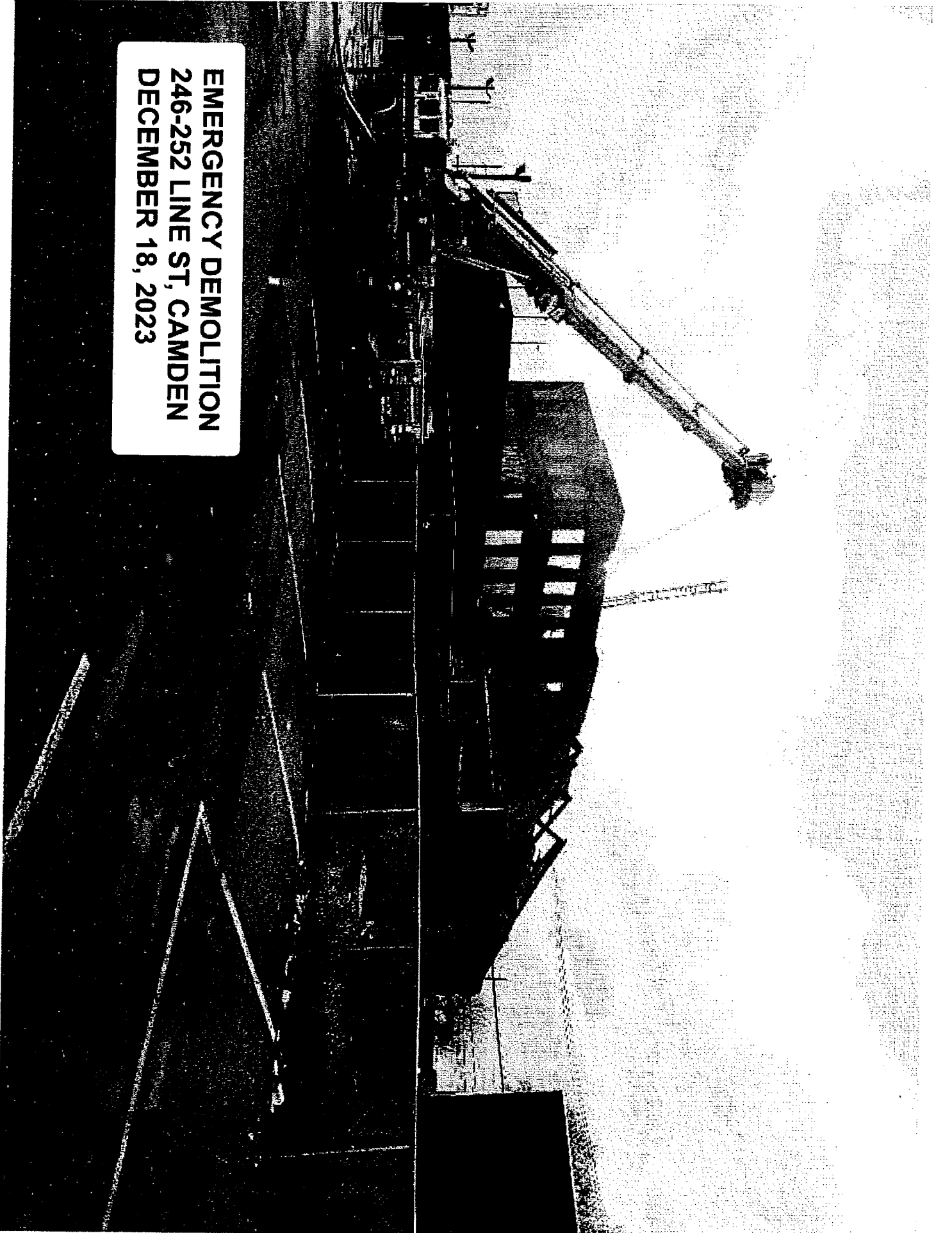

EMERGENCY DEMOLITION
246-252 LINE ST, CAMDEN
DECEMBER 18, 2023

PUBLIC SERVICE ELECTRIC & GAS COMPANY
PO BOX 1023,
CRANFORD, NJ 07016-1023
Phone: 800-817-3366 Fax: 908-497-1878
E-mail: demolition@pseg.com

EMERGENCY DEMOLITION
246-252 LINE ST, CAMDEN
DECEMBER 18, 2023

PSE&G SERVICE REMOVAL REQUEST FORM

Office Use Only: Project # _____ G1# _____ E1# _____

REVIEW APPLICATION INSTRUCTIONS BEFORE COMPLETING

COMPANY NAME *if applicable*: CITY OF CAMDEN

OWNER'S NAME: BROADWAY FAMILY CTR, INC

OWNER'S AUTHORIZED AGENT name and title: N/A

SERVICE ADDRESS: 246-252 LINE ST TOWN: CAMDEN
(OF BLDG TO BE DEMOLISHED)

CROSS STREET: SO 3RD ST

OWNER'S MAILING ADDRESS: 250 LINE S, CAMDEN, NJ 08103
(This is where the service removal completion letter will be sent)

OWNER'S PRIMARY RESIDENCE? (CIRCLE ONE) YES (NO)

PREMISE VACANT? (CIRCLE ONE) (YES) NO

IMPORTANT: APPLICATION WILL NOT BE ACCEPTED UNTIL APPLICANT HAS TAKEN OWNERSHIP AND PROPERTY IS VACANT.

PROJECT CONTACT: JAMES R RIZZO FAX: JARIZZO@CI.CAMDEN.NJ.US

PRIMARY PHONE: 609-319-9883 (OR E-MAIL) ALTERNATE PHONE: N/A

METER NUMBERS: Gas N/A Electric N/A

TYPE AND NUMBER OF STRUCTURES TO BE DEMOLISHED: N/A
DOES THE STRUCTURE TO BE DEMOLISHED HAVE MORE THAN ONE ADDRESS? **A separate form is required for each address.**

PSE&G LIGHTING TO BE REMOVED? (CIRCLE ONE) YES (NO)

PSE&G POLES TO BE REMOVED? (CIRCLE ONE) YES (NO)
POLE#(S) **required**: _____

OTHER PSE&G EQUIPMENT?(TRANSFORMER, SWITCHGEAR, ETC.) YES NO
TYPE OF ELECTRICAL SERVICE: (CIRCLE ONE) (OVERHEAD) UNDERGROUND

ARE YOU AWARE OF ANY ENVIRONMENTAL ISSUES AT THIS SITE? YES NO
PLEASE EXPLAIN _____

TYPE OF STRUCTURE TO BE BUILT AFTER DEMOLITION: N/A
APPROXIMATE DATE OF RECONSTRUCTION: N/A

SIGNATURE:  PRINT NAME: JAMES R RIZZO

DATE: DECEMBER 18, 2023

BY SUBMITTING THIS APPLICATION YOU ARE CERTIFYING THAT YOU ARE AUTHORIZED TO REQUEST REMOVAL OF ELECTRIC AND GAS SERVICES AT THE PROPERTY SPECIFIED AND THAT PREMISE IS VACANT. Proof of ownership required at time of application. Please refer to the instructions sent with this form for list of acceptable forms of proof.

CITY OF CAMDEN

EMERGENCY CONTRACT TO PROVIDE FOR THE DEMOLITION OF A RESIDENTIAL PROPERTY, THE REMOVAL OF ALL STRUCTURES, CONTENTS AND ALL OTHER DEBRIS, WHETHER ABOVE OR BELOW GROUND, AT 246-252 LINE STREET, BLOCK 226, LOT 28, FINAL RESTORATION AND GRADING OF THIS PROPERTY IN THE CITY OF CAMDEN

This Emergency Demolition is encompassed by the Standard City Demolition Specifications, which are incorporated by reference and made a part hereto, and the following, special provisions.

On December 18, 2023, the City of Camden Construction Official conducted an inspection of the structure at 246-252 Line Street, Block 226, Lot 28, and determined that it is an unsafe structure and imminent hazard: major fire. These unsafe conditions make this structure extremely dangerous to the residents. The Construction Official provided the owner until December 19, 2023 to demolish the structure or correct the unsafe conditions. The owner has failed to do so and the Construction Official has determined that the building structure must be promptly demolished.

By this emergency quote, the City of Camden is seeking one (1) contractor to provide for the demolition of the residential property at 246-252 Line Street, Block 226, Lot 28, the removal of all structures, contents and all other debris, whether above or below ground, and final restoration and grading of the property in the City of Camden.

The Contractor must respond by no later than 9:00 am on Tuesday, December 19, 2023. The Purchasing Bureau will contact the successful vendor by telephone/email with notice to proceed.

Contractor must secure the property immediately after being notified of the award on Tuesday, December 19, 2023 for public safety. A Portable six-foot (6') metal cyclone fence must be erected around the pedestrian walkway(s) of the structure(s) to be demolished. **(NO EXCEPTIONS). Any immediate hazards [falling debris, etc.] that has the potential to fall outside of the fencing must be corrected at that time. Contractor must begin demolition by 10:00 am on Tuesday, December 19, 2023.**

Contractor shall ensure that dust be kept to a minimum by spraying the site with water during the demolition. Sidewalks should be made passable and left broom clean daily during the course of your demolition operations.

All Contractor signage shall be removed from the worksite at the time the job is completed. This requirement is a condition prior to receipt of final payment.

PLEASE BE ADVISED

- **EMERGENCY CONTRACT TO PROVIDE FOR THE DEMOLITION OF A RESIDENTIAL PROPERTY, THE REMOVAL OF ALL STRUCTURES, CONTENTS AND ALL OTHER DEBRIS, WHETHER ABOVE OR BELOW GROUND, AT 246-252 LINE STREET, BLOCK 226, LOT 28, FINAL RESTORATION AND GRADING OF THIS PROPERTY IN THE CITY OF CAMDEN**
- **Any tanks or containers on the property must be removed from the property and such removal costs shall be included in the bid price sheet. All such removal work shall be done in accordance with and comply with all applicable federal, state, and local laws, ordinances, rules and regulations. Furthermore, the Contractor must comply with the New Jersey Department of Labor procedures, rules, and regulations, including providing appropriate documents, affidavits and/or certifications.**
- **Contractor must secure subject site with sufficient and appropriate security fencing while the Contractor is performing the emergency demolition in order to adequately protect the public health, safety and welfare of the citizens of the City.**
- **All costs for asbestos and tank and/or container removals must be included in the Bid Price Sheet's Lump Sum Payments. The City of Camden will not pay any additional costs for these removals.**
- **AWARD WILL BE BASED ON THE TOTAL AMOUNT OF THE QUOTE.**

***EXCEPTION:** If asbestos or other contamination is verified, then the demolition time schedule is referred to the Construction Official.

A Certificate of Environmental Compliance and Hold Harmless Agreement issued by the City Construction Official are attached to this fax; they must be completed and returned with the Proposal prior to any award and demolition work. Return of the Certificates is MANDATORY; otherwise said proposal will be rejected. The worksite must remain secure until project is properly abated.

The dollar amount for all demolition quotes must be submitted in two written versions as per example.

Example: "Seven thousand five hundred dollars" and \$ 7,500.00

PLEASE NOTE: In the event of a tie for emergency demolition request, the determining factor will be awarded to the contractor who submits their proposal the earliest

BID PRICE SHEET

EMERGENCY CONTRACT TO PROVIDE FOR THE DEMOLITION OF A RESIDENTIAL PROPERTY, THE REMOVAL OF ALL STRUCTURES, CONTENTS AND ALL OTHER DEBRIS, WHETHER ABOVE OR BELOW GROUND, AT 246-252 LINE STREET, BLOCK 226, LOT 28, FINAL RESTORATION AND GRADING OF THIS PROPERTY IN THE CITY OF CAMDEN

\$ 113,000.⁰⁰
TOTAL

Total Bid Amount in Words: ONE HUNDRED THIRTEEN
THOUSAND DOLLARS AND NO/CENTS

NOTE: THE ABOVE LUMP SUM PAYMENTS MUST INCLUDE ALL COSTS, INCLUDING REMOVAL OF ALL DEBRIS, WHETHER ABOVE OR BELOW GROUND, ASBESTOS ABATEMENT, REMOVAL OF ABOVE GROUND OIL, PROPANE OR OTHER TYPES OF TANKS OR CONTAINERS, INCLUDING ABOVE GROUND OIL, PROPANE OR OTHER TYPES OF TANKS OR CONTAINERS LOCATED IN THE BASEMENT OF THE STRUCTURE(S) TO BE DEMOLISHED, ALL RESTORATION AND GRADING COSTS AND ALL OTHER COSTS.

PLEASE NOTE: GAS AND ELECTRIC SERVICES TO 246-252 LINE STREET, BLOCK 226, LOT 28, CAMDEN, NEW JERSEY HAVE BEEN DISCONNECTED BY PSE&G.

THE ABOVE LUMP SUM PAYMENTS MUST INCLUDE ALL COSTS ASSOCIATED WITH OTHER DISCONNECTION COSTS AS WELL AS DISCONNECTION OF APPURTENANT EQUIPMENT SUCH AS METERS, REGULATORS, AND GAUGES AND THE COORDINATION AND SCHEDULING THEREOF.

PLEASE NOTE: THE BIDDER WILL NOT BE RESPONSIBLE FOR WATER AND SEWER DISCONNECTS OR FOR THE COSTS FOR THESE WATER AND SEWER DISCONNECTS SINCE THE WATER AND SEWER DISCONNECT SERVICES ARE TO BE PROVIDED BY AMERICAN WATER.

Fees for any additional charges not listed in this bid sheet are expressly not permitted under the contract.

I HEREBY submit and confirm this Bid Price Sheet, subject to all requirements and conditions stated in these bid specifications.

Company Name: Winzinger, Inc.

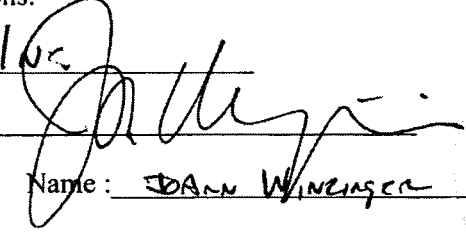
Bidder's Corporate Officer's Signature: 

print name) Name: JOHN WINZINGER (

(print title) Title: President

Date: 12/19/23



CERTIFICATE OF ENVIRONMENTAL COMPLIANCE

Name of Contractor: WINZINGER, INC.

I, JOHN WINZINGER, hereby agree to hold harmless the City of Camden, its successors and assignees, or its officials, officers, employees and agents, for any injuries to person or property incurred on losses suffered on account of the demolition of 246-252 LINE STREET

I certify upon inspection of the property that there is no asbestos or visible hazardous tanks. The contractor will not be responsible for the removal of subsurface tanks unless otherwise noted by the City of Camden. If either of these items are identified, they will be removed in accordance with applicable federal, state, and local laws, ordinances, rules and regulations. Including, the New Jersey Department of Labor procedures, rules, and regulations, including providing appropriate documents, affidavits and/or certifications and also N.J.S.A 52:27D – 119 et. Seq.

Asbestos		Tanks	
Yes	No	Yes	No
<u> </u>	<u> ✓ </u>	<u> </u>	<u> ✓ </u>

By: [Signature]

Sworn and subscribed to before me
On this 19 day of December 2023
[Signature]
NOTARY PUBLIC

WILLIAM K. CHALLENGER
NOTARY PUBLIC OF NEW JERSEY
Commission # 2334691
My Commission Expires 9/20/2025

R-27

DB:dh
03-12-24

RESOLUTION AMENDING A SHARED SERVICES AGREEMENT BETWEEN THE CITY OF CAMDEN AND CAMDEN COUNTY IMPROVEMENT AUTHORITY TO PROVIDE FOR REIMBURSEMENT OF EMERGENCY DEMOLITION COSTS

WHEREAS, the Council of the City of Camden by Resolution R-6 (MC-23:8862) dated March 14, 2023 approved a Shared Services Agreement with Camden County Improvement Authority to serve as project management for the demolition between of 100 and 300 unsafe structures throughout the City of Camden that will eliminate blight and facilitate various planned redevelopment project and future development parcels; and

WHEREAS, the City wishes to amend the Shared Services Agreement to include the reimbursement of emergency demolition costs, which CCIA shall receive up to Fifteen Million Dollars of the State of New Jersey funds for demolition of abandon, blighted properties throughout the City; now, therefore

BE IT RESOLVED, by the City Council of the City of Camden that Shared Services Agreement between the City of Camden and Camden County Improvement Authority be amended to include the reimbursement of emergency demolition costs, which CCIA shall receive up to Fifteen Million Dollars of the State of New Jersey funds for demolition of abandon, blighted properties throughout the City.

BE IT FURTHER RESOLVED, that pursuant to N.J.S.A. 52:27BBB-23, a true copy of this Resolution shall be forwarded to the State Commissioner of Community Affairs, who shall have ten (10) days from the receipt thereof to veto this Resolution. All notices of veto shall be filed in the Office of the Municipal Clerk.

Date: March 12, 2024

The above has been reviewed and approved as to form.



DANIEL S. BLACKBURN
City Attorney

ANGEL FUENTES
President, City Council

ATTEST: _____
LUIS PASTORIZA
Municipal Clerk



CITY OF CAMDEN — CITY COUNCIL ACTION REQUEST FORM

COUNCIL MEETING DATE: 3/12/24

TO: City Council
FROM: Timothy J. Cunningham, Business Administrator

TITLE OF ORDINANCE/RESOLUTION: Resolution Amending A Shared Services Agreement Between The City And The Camden County Improvement Authority To Provide For Reimbursement Of Emergency Demolition Costs.

Point of Contact:	Timothy J. Cunningham	Administration	7150	
	Name	Department-Division-Bureau	Phone	Email

ENDORSEMENTS

Responsible Department Director Supporting Department Director (if necessary) Director of Grants Management Qualified Purchasing Agent Director of Finance	Recommend Approval (Y/N)	Signature	Date	Comments
				

Approved by:
Business Administrator

Signature	Date

Attachments (list and attach all available):

1. Waiver Request Form Attached for State DCA/DLGS Approval - (If applicable)¹
2. Certification of Funds²
3. Addition supporting documents.

"Walk-on" note: All walk-on legislation must be pre-approved by the Business Administrator. The Department Director and Contact Person are jointly responsible for delivering all necessary documents to the City Clerk for distribution at the Council Meeting.

Received by:
City Attorney

Signature	Date
	10 Mar 24

¹ For Example: Form "A" - Request for approval of Employees Requiring Advice and Consent of Governing Body, Form "D" - Contract Request, Form "E" - Creation/Extension of Services, Form "G" - Grant Approval, Form "H" - Bond Ordinance or Contract Request, Form "I", "Best Price Insurance Contracting" Model Ordinance

² Mandatory for any financial commitment to the City or expenditure of City Funds.

EXECUTIVE SUMMARY

TITLE OF ORDINANCE/RESOLUTION: Resolution Amending A Shared Services Agreement Between The City And The Camden County Improvement Authority To Provide For Reimbursement Of Emergency Demolition Costs.

FACTS/BACKGROUND: (Executive level details. Short concise bullets)

- CCIA Performs Program Management Services, Projects and Construction Management services, for program s and individual project involving the county of Camden, its affiliated agencies and municipalities to maximize economies and efficiencies in the operations.
- CCIA and Camden City agree that their mutual public purposes and their best interest will be promoted by execution and delivery of this Shared Services Agreement pursuant to the powers conferred by the Uniform Shared Services And Consolidation Act.
- CCIA shall receive up to fifteen million dollars of State of New Jersey Funds for the demolition of abandon, blighted properties throughout Camden City.

AMOUNT OF PROPOSED CONTRACT or TOTAL COST OF PROPOSAL:

IMPACT STATEMENT:

The Purpose of the Agreement is for CCIA to provide the most cost-effective services to Camden City and the residents of Camden and the County for the authorization and project Management services the demolition of abandoned, blighted and vacant properties indemnified by Camden City.

SUBJECT MATTER EXPERTS/ADVOCATES:

- City of Camden / Camden County Improvement Authority

COORDINATION:

- City of Camden

Prepared by:

Diana Gonzalez

Ext. 7150

Name

Phone/Email

**STATE OF NEW JERSEY
DEPARTMENT OF COMMUNITY AFFAIRS
DIVISION OF LOCAL GOVERNMENT SERVICES
CONTRACT REQUEST FORM**

This form must be filled out in its entirety and is intended to provide the Division with appropriate information to determine whether to approve a new or extended service. Please provide any additional information you believe will help the Division make an informed decision.

Municipality	City of Camden
--------------	----------------

Professional Service or EUS Type	Shared Services Agreement
Name of Vendor	Camden County Improvement Authority
Purpose or Need for service:	Resolution Amending A Shared Services Agreement Between The City of Camden and the Camden County Improvement Authority To Provide For Reimbursement Of Emergency Demolition Costs.
Contract Award Amount	CCIA Shall Receive Up To Fifteen Million Dollars of the State of New Jersey Funds for demolition of abandon, blighted properties throughout the city.
Term of Contract	Duration of Project (Estimated Fourteen Months)
Temporary or Seasonal	N/A
Grant Funded (attach appropriate documentation allowing for service through grant funds)	SSA Attached w/Details
Please explain the procurement process (i.e. bids, RFQ, competitive contracting, etc.)	N/A
Were other proposals received? If so, please attach the names and amounts for each proposal received?	N/A

Please attach the RFP, evaluation memoranda or evaluation forms used to evaluate the vendors and a list of all bidders and the bid amounts associated with each bidder.

If the lowest bidder was not selected, please have the appropriate personnel sign the certification on page 2.

Mayor's Signature*

Date_____

Business Administrator/Manager Signature

Date_____

*For direct appointments of the Governing Body, Council President or at the discretion of the Director, the most senior member of the Governing Body may sign the waiver in lieu of the Mayor.

The Chief Financial Officer affirms that there is adequate funding available for this personnel action.
_____ Funding Source for this action

Chief Financial Officer Signature

I certify that the vendor selected is in compliance with the adopted Pay to Play Ordinance and that the vendor was notified of any restrictions with respect to campaign contributions.

Certifying Officer

Date _____

For LGS use only:

Approved Denied

Director or Designee,
Division of Local Government Services

Number Assigned _____

SHARED SERVICES AGREEMENT
BY AND BETWEEN THE
CAMDEN COUNTY IMPROVEMENT AUTHORITY
AND
CITY OF CAMDEN

THIS DOCUMENT constitutes a “Shared Services Agreement” (“Amendment”) made by and between the Camden County Improvement Authority, a body politic and corporate of the State of New Jersey, having its principal place of business at 520 Market Street, Suite, 4300, Camden, NJ 08101 (the “CCIA”) and the City of Camden, municipal corporation of the State of New Jersey, having its principal place of business at 520 Market Street, Camden, NJ 08101, (“Camden City”) (collectively the “Parties”). The date of execution of this amendment is the day of , 2024.

WITNESSETH:

WHEREAS, the CCIA performs program management services (“Services”), project and construction management services, for programs and individual Projects involving the County of Camden, its affiliated agencies and municipalities to maximize economies and efficiencies in the operations of County or Municipal government; and

WHEREAS, The CCIA shall receive up to fifteen million dollars of State of New Jersey funds for the demolition of abandon, blighted properties throughout Camden City (“Project”); and

WHEREAS, CCIA has the expertise and capability to provide comprehensive Services to Camden City for the authorization and management of this Project;

WHEREAS, N.J.S.A. 40A:65-1, *et seq* (“Uniform Shared Services and Consolidation Act”) permits two local units to enter into a contract for any service which any party to the agreement is empowered to render within its jurisdiction; and

WHEREAS, the CCIA and Camden City agree that their mutual public purposes and their best interest will be promoted by the execution and delivery of this Shared Services Agreement pursuant to the powers conferred by the Uniform Shared Services and Consolidation Act; and

WHEREAS, by Resolution No. ____ adopted by Camden city's Council, and Resolution No. ____ adopted by the Camden County Improvement Authority, the Parties are authorized to enter into this Agreement.

NOW, THEREFORE, IN CONSIDERATION of the mutual covenants and promises herein contained, it is agreed by and between the parties as follows:

1. PURPOSE AND SCOPE.

The purpose of the Agreement is for the CCIA to provide the most cost-effective services to Camden City Camden City and the residents of Camden and the County for the authorization and project management services the demolition of abandoned, blighted and vacant properties indemnified by Camden City.

2. DUTIES AND RESPONSIBILITIES.

The specific duties and responsibilities of the CCIA is set forth in the proposal for Program Management Services, which is attached as Exhibit "A" and incorporated by reference herein including the scope of work to be performed and the overall project schedule. No additional services shall be performed without approval of both Parties.

The specific duties and responsibilities of the City for this Project shall be to approve the list of properties to be demolished and send this list to the CCIA. This will be the official list of units the CCIA shall use to bid out for demolition. The City shall guarantee to the CCIA that they have met all legal and mandatory obligations to list the properties for demolition. The CCIA shall not be responsible for any actions taken for properties sent to the CCIA for demolition. Both parties will work collectively to prioritize the units that should be addressed in the first phase of demolition.

Financing for this project will be provided by the State of New Jersey and shall be earmarked by the CCIA for the advancement of this Project only. All funds awarded to the CCIA shall be allocated to

the demolition of the units and the associated costs that are necessary to complete this project including soft costs such as permits, fees, engineering and environmental services, and others as needed by the CCIA.

A. Reporting

The CCIA will work directly with Camden City staff in providing the Services and provide regular progress reports in a format and schedule acceptable to Camden City.

B. Facilities

Camden City shall provide use of its facilities to the CCIA as may be required to perform the Services.

C. Clerical Support

Camden City shall provide reasonable clerical and administrative support as may be requested by the CCIA to perform these services provided that requested by CCIA does not require the addition of any clerical or administrative staff or Camden City incurring overtime payroll obligations.

3. FUNDING.

As noted, funding for this Project will come from the State of New Jersey. The CCIA and Camden City shall comply with all requirements the State has mandated for this Project. The CCIA and City shall not have any obligation to fund any portion of the Project unless both parties agree it is necessary to complete any open tasks. If the City undertakes any emergency demolition to the properties on the approved Camden City Demolition list, the CCIA will reimburse the City for these costs out of the State funding. The CCIA reserves the right to review all documentation and payments and has the ability not to pay for an emergency demolition if not on the approved list or if not provided adequate notice. The City shall ask for reimbursement for only the properties on the list.

4. CONFLICT OF INTEREST.

The CCIA represents that it is not aware of any conflict based upon its understanding of the Services to be provided under this Agreement and further agrees that in performing the Services it will

comply with all applicable standards of conduct including but not limited to the New Jersey Local Government Ethics Law in providing Services and will avoid and disclose to Camden City any real conflict of interest or any appearance of a conflict of interest in the event that one arises.

5. TERM AND TERMINATION.

The term of this Agreement shall be for the duration of the Project (estimated fourteen months) and subject to renewal for an additional year or other agreed upon time frame by mutual agreement of the CCIA and Camden City. In addition, either party may terminate the agreement by providing thirty (30) days written notification to the other party for any reason or no reason whatsoever.

6. NOTICES.

All notices hereunder shall be in writing and mailed postage prepaid, certified mail, return receipt requested to the parties at the addresses listed herein above.

7. INDEMNIFICATION

The Parties shall indemnify and hold each other harmless and defend the other Party, their elected officials, employees, officers and agents, from and against all liability, claims, suits, losses, damages, costs and demands, on account of bodily injury, including death or property damage, arising out of or connected with their performance of services under this Agreement.

8. INSURANCE

The Parties agree to maintain liability and workers compensation insurance for the acts of their elected officials, employees, officers and agents.

9. MISCELLANEOUS PROVISIONS.

The following miscellaneous provisions shall apply to this Agreement:

a. Governing Law

The Parties acknowledge that this Agreement was prepared pursuant to New Jersey law and that the laws of the State of New Jersey shall apply.

b. Waiver

Failure to enforce any of the provisions of this Agreement by any of the Parties shall not be construed as a waiver of the provisions.

c. Amendment for Modification

This Agreement may not be modified, altered, or amended in any manner, except in writing, signed by the Parties hereto and approved by the governing bodies as may be required.

d. Heading

This section and any other headings contained in this Agreement are for reference purposes only and shall not affect meaning or interpretation of this Agreement.

e. Invalid Clause

The invalidity of any clause contained herein shall not render any other provision invalid and the balance of this Agreement shall be binding upon all Parties hereto.

f. Entire Agreement

This Agreement shall consist of the entire agreement of the Parties and it is acknowledged that there is no side or oral agreements relating to the understandings set forth herein.

g. Assignability

This Agreement and all rights, duties and obligations contained herein may not be assigned without prior written consent from either party which consent may be unreasonably withheld.

h. Affirmative Action

The Parties hereby agree to incorporate the affirmative action language attached hereto.

i. Americans with Disabilities/Equal Employment Opportunity

The Parties hereby agree to comply with the Americans with Disabilities Act and Equal Employment Opportunity Act as set forth in the attached Exhibits ___ and ____.

j. Audit

The CCIA shall permit Camden City and/or its independent auditors to have access, at a reasonable time and place, to the records and financial statements necessary to comply with the following audit requirements as may be applicable:

Type of Contractors Audit Requirements

Non-Profits and Institutions
of Higher Education

State Funds –
N.J.O.M.B. Circular
Letter 98-07

State and Local Governments

Federal Funds -
OMB Circular A-133
(Revised)

State Funds -
N.J.O.M.B. Circular
Letter 98-07

Federal Funds -
OMB Circular A-133
(Revised)

For Profits

County's requirement of access as
detailed above.

Copies of the above-referenced circulars are available upon request from the Camden County Chief Financial Officer. **All non-profits, institutions of higher education, and state and local government contractors shall annually forward a copy of their Single Audit Report to Camden County at 520 Market Street, Camden, New Jersey 08102-1375.**

k. Funding

Pursuant to N.J.S.A. 40A: 11-15, this Agreement is subject to the availability and appropriation of sufficient funds each year in which it is in effect.

l. Binding Agreement

This Agreement shall be binding upon the Parties hereto and their respective administrators, successors or assigns.

SIGNATURE PAGE ATTACHED HERETO

IN WITNESS, WHEREOF, the parties have hereunto set their hands and seals on the day and year first above written.

Witness:

CAMDEN COUNTY IMPROVEMENT AUTHORITY

By: _____

James Lex, Acting Executive Director

CITY OF CAMDEN

By: _____

Victor Carstarphen, Mayor

MANDATORY EQUAL EMPLOYMENT OPPORTUNITY LANGUAGE

N.J.S.A. 10:5-31 et seq. (P.L. 1975, C. 127)

N.J.A.C. 17:27

GOODS, PROFESSIONAL SERVICE AND GENERAL SERVICE CONTRACTS

During the performance of this contract, the contractor agrees as follows:

The contractor or subcontractor, where applicable, will not discriminate against any employee or applicant for employment because of age, race, creed, color, national origin, ancestry, marital status, affectional or sexual orientation, gender identity or expression, disability, nationality or sex. Except with respect to affectional or sexual orientation and gender identity or expression, the contractor will ensure that equal employment opportunity is afforded to such applicants in recruitment and employment, and that employees are treated during employment, without regard to their age, race, creed, color, national origin, ancestry, marital status, affectional or sexual orientation, gender identity or expression, disability, nationality or sex. Such equal employment opportunity shall include, but not be limited to the following: employment, upgrading, demotion, or transfer; recruitment or recruitment advertising; layoff or termination; rates of pay or other forms of compensation; and selection for training, including apprenticeship. The contractor agrees to post in conspicuous places, available to employees and applicants for employment, notices to be provided by the Public Agency Compliance Officer setting forth provisions of this nondiscrimination clause.

The contractor or subcontractor, where applicable will, in all solicitations or advertisements for employees placed by or on behalf of the contractor, state that all qualified applicants will receive consideration for employment without regard to age, race, creed, color, national origin, ancestry, marital status, affectional or sexual orientation, gender identity or expression, disability, nationality or sex.

The contractor or subcontractor will send to each labor union, with which it has a collective bargaining agreement, a notice, to be provided by the agency contracting officer, advising the labor union of the contractor's commitments under this chapter and shall post copies of the notice in conspicuous places available to employees and applicants for employment.

The contractor or subcontractor, where applicable, agrees to comply with any regulations promulgated by the Treasurer pursuant to N.J.S.A. 10:5-31 et seq., as amended and supplemented from time to time and the Americans with Disabilities Act.

The contractor or subcontractor agrees to make good faith efforts to meet targeted county employment goals established in accordance with N.J.A.C. 17:27-5.2.

The contractor or subcontractor agrees to inform in writing its appropriate recruitment agencies including, but not limited to, employment agencies, placement bureaus, colleges, universities, and labor unions, that it does not discriminate on the basis of age, race, creed, color, national origin, ancestry, marital status, affectional or sexual orientation, gender identity or expression, disability, nationality or sex, and that it will discontinue the use of any recruitment agency which engages in direct or indirect discriminatory practices.

The contractor or subcontractor agrees to revise any of its testing procedures, if necessary, to assure that all personnel testing conforms with the principles of job-related testing, as established by the statutes and court decisions of the State of New Jersey and as established by applicable Federal law and applicable Federal court decisions.

In conforming with the targeted employment goals, the contractor or subcontractor agrees to review all procedures relating to transfer, upgrading, downgrading and layoff to ensure that all such actions are taken without regard to age, race, creed, color, national origin, ancestry, marital status, affectional or sexual orientation, gender identity or expression, disability, nationality or sex, consistent with the statutes and court decisions of the State of New Jersey, and applicable Federal law and applicable Federal court decisions.

The contractor shall submit to the public agency, after notification of award but prior to execution of a goods and services contract, one of the following three documents:

Letter of Federal Affirmative Action Plan Approval
Certificate of Employee Information Report

Employee Information Report Form AA302 (electronically provided by the Division and distributed to the public agency through the Division's website at www.state.nj.us/treasury/contract_compliance)

The contractor and its subcontractors shall furnish such reports or other documents to the Division of Public Contracts Equal Employment Opportunity Compliance as may be requested by the office from time to time in order to carry out the purposes of these regulations, and public agencies shall furnish such information as may be requested by the Division of Public Contracts Equal Employment Opportunity Compliance for conducting a compliance investigation pursuant to **Subchapter 10 of the Administrative Code at N.J.A.C. 17:27.**

AMERICANS WITH DISABILITIES ACT

Mandatory Language

Equal Opportunity for Individuals with Disabilities.

The Contractor and the County do hereby agree that the provisions of Title II of the Americans With Disabilities Act of 1990 (the "Act") (42 U.S.C. s12101 et seq.), which prohibits discrimination on the basis of disability by public entities in all services, programs, and activities provided or made available by public entities, and the rules and regulations promulgated pursuant thereto, are made a part of this contract. In providing any aid, benefit, or service on behalf of the County pursuant to this contract, the Contractor agrees that the performance shall be in strict compliance with the Act. In the event that the Contractor, its agents, servants, employees, or subcontractors violate or are alleged to have violated the Act during the performance of this contract, the Contractor shall defend the County in any action or administrative proceeding commenced pursuant to this Act. The Contractor shall indemnify, protect, and save harmless the County, its agents, servants, and employees from and against any and all suits, claims, losses, demands, or damages of whatever kind or nature arising out of or claimed to arise out of the alleged violation. The Contractor shall, at its own expense, appear, defend, and pay any and all charges for legal services and any and all costs and other expenses arising from such action or administrative proceeding or incurred in connection therewith. In any and all complaints brought pursuant to the County's grievance procedure, the Contractor agrees to abide by any decision of the County, which is rendered pursuant to, said grievance procedure. If any action or administrative proceeding results in an award of damages against the County or if the County incurs any expense to cure a violation of the ADA which has been brought pursuant to its grievance procedure, the Contractor shall satisfy and discharge the same at its own expense.

The County shall, as soon as practicable after a claim has been made against it, give written notice thereof to the Contractor along with full and complete particulars of the claim. If any action or administrative proceeding is brought against the County or any of its agents, servants, and employees, the County shall expeditiously forward or have forwarded to the Contractor every demand, complaint, notice, summons, pleading, or other process received by the County or its representatives.

It is expressly agreed and understood that any approval by the County of the services provided by the Contractor pursuant to this contract will not relieve the Contractor of the obligation to comply with the Act and to defend, indemnify, protect, and save harmless the Owner pursuant to this paragraph.

It is further agreed and understood that the Owner assumes no obligation to indemnify or save harmless the Contractor, its agents, servants, employees and subcontractors for any claim which may arise out of their performance of this agreement. Furthermore, the Contractor expressly understands and agrees that the provisions of this indemnification clause shall in no way limit the Contractor's obligations assumed in this agreement, nor shall they be construed to relieve the Contractor from any liability, nor preclude the Owner from taking any other actions available to it under any other provisions of this agreement or otherwise at law.

EXHIBIT A

SCOPE OF SERVICES:

The Camden County Improvement Authority (CCIA) will provide Demolition Program Management services to the City of Camden. The CCIA and Camden City will work jointly together to complete the demolition of ~~abandon properties~~ abandon properties. The City of Camden will provide the approved list of properties to be razed and the CCIA shall do the following:

:

- 1) Procure the needed consultants and/or design professional, (i.e.; Architects, Engineers, and others as needed)
- 2) Preparing initial project budgets and schedule and provide these documents for City reviews
- 3) Hold stakeholder and Community Meetings and work with the City to ensure community awareness of the project
- 4) Prepare all bidding and procurement documents to complete this project
- 5) Hold all necessary demolition contracts
- 6) Work with the utilities companies to disconnect all utilities to the identified units
- 7) Hold biweekly project meetings with needed City officials and Staff to keep the City and State aware of the project status
- 8) Process all necessary payments for this Project and provide a monthly budget report to the City and State for review.
- 9) Ensure all bidding documents reflect City participation for the duration of this project
- 10) Work with City Officials to identify properties that are on the official City List that may have some potential for rehabilitation by other entities.
- 11) Work with the City on the liquidation of these properties, as needed, to allow the City to advance and redevelopment activities associated with these properties
- 12) Work with the City to provide funding for units that were demolished on an emergency basis but only on approved units.

R-28

DB
03-12-24

**RESOLUTION DETERMINING THE FORM AND OTHER
DETAILS OF \$2,000,000 GENERAL IMPROVEMENT BONDS,
SERIES 2024, OF THE CITY OF CAMDEN, IN THE COUNTY OF
CAMDEN, NEW JERSEY, AND PROVIDING FOR THEIR SALE.**

BE IT RESOLVED BY THE CITY COUNCIL OF THE CITY OF CAMDEN, IN THE COUNTY OF CAMDEN, NEW JERSEY (with not less than a majority of the full membership thereof affirmatively concurring), AS FOLLOWS:

Section 1. (a) The \$2,000,000 General Improvement Bonds, Series 2024, of the City of Camden, in the County of Camden, New Jersey (the "City"), referred to and described in bond ordinance #MC-5110 of the City finally adopted on May 18, 2018 and providing for traffic and infrastructure improvements, in all respects duly approved and published as required by law, shall be issued as "General Improvement Bonds, Series 2024" (the "Bonds").

(b) The Bonds shall mature in the principal amounts on April 1 as follows:

<u>Year</u>	<u>Principal Amount</u>	<u>Year</u>	<u>Principal Amount</u>
2025	\$250,000	2028	\$500,000
2026	250,000	2029	500,000
2027	500,000		

(c) The actual principal amounts may be adjusted by the City, at its option, in accordance with N.J.S.A. 40A:2-26(g). Any such adjustment shall not exceed 10% of the principal for any maturity with the aggregate adjustment to maturity not to exceed 10% of the principal for the overall issue.

(d) The Bonds shall not be subject to redemption prior to their stated maturities.

(e) The Bonds shall be five in number, with one certificate being issued for each year of maturity, and shall be numbered GI-1 to GI-5, inclusive.

Section 2. (a) The Bonds shall be dated their date of issuance and shall bear interest payable semiannually on the first day of April and October in each year until maturity, commencing on October 1, 2024, at a rate or rates per annum, expressed in a multiple of 1/8 or 1/20 of 1%, proposed by the successful bidder in accordance with the Notice of Sale attached hereto as Exhibit A (the "Notice of Sale").

(b) The Bonds shall be executed by the manual or facsimile signatures of the Mayor and the Chief Financial Officer under the official seal (or facsimile thereof) affixed, printed, engraved or reproduced thereon and attested by the manual signature of the City Clerk.

Section 3. (a) The Bonds will be issued in fully registered form. One certificate shall be issued for the aggregate principal amount of each series of the Bonds maturing in each year.

Both principal of and interest on the Bonds will be payable in lawful money of the United States of America. Each certificate will be registered in the name of Cede & Co., as nominee for The Depository Trust Company, Brooklyn, New York, which will act as securities depository (the "Securities Depository"). The certificates will be on deposit with the Securities Depository. The Securities Depository will be responsible for maintaining a book-entry system for recording the interests of its participants or the transfers of the interests among its participants. The participants will be responsible for maintaining records recording the beneficial ownership interests in the Bonds on behalf of individual purchasers. Individual purchases may be made in the principal amount of \$5,000 through book-entries made on the books and records of the Securities Depository and its participants.

(b) The principal of and interest on the Bonds will be paid to the Securities Depository by the City on the respective maturity dates and due dates and will be credited on the respective maturity dates and due dates to the participants of the Securities Depository as listed on the records of the Securities Depository as of each next preceding March 15 and September 15 (the "Record Dates" for the Bonds).

Section 4. The Bonds shall be substantially in the following form with such additions, deletions and omissions as may be necessary for the City to market the Bonds, including in accordance with the requirements of the Securities Depository:

REGISTERED
NUMBER GI-__

REGISTERED
\$_____

UNITED STATES OF AMERICA
STATE OF NEW JERSEY
COUNTY OF CAMDEN

CITY OF CAMDEN

GENERAL IMPROVEMENT BOND, SERIES 2024

REGISTERED OWNER:	Cede & Co.
PRINCIPAL AMOUNT:	\$_____
DATED DATE:	April 25, 2024
MATURITY DATE:	April 1, 20__
RATE OF INTEREST PER ANNUM:	___%
INTEREST PAYMENT DATES:	April 1 and October 1
INITIAL INTEREST PAYMENT DATE:	October 1, 2024
RECORD DATES:	March 15 and September 15
CUSIP NUMBER:	_____

CITY OF CAMDEN, a public body corporate and politic of the State of New Jersey (the "City"), hereby acknowledges itself indebted and for value received promises to pay to the REGISTERED OWNER, or registered assigns, on the MATURITY DATE, upon presentation and surrender of this bond, the PRINCIPAL AMOUNT, and to pay interest on such sum from the DATED DATE until it matures at the RATE OF INTEREST PER ANNUM specified above semiannually on the INTEREST PAYMENT DATES in each year until maturity, commencing on the INITIAL INTEREST PAYMENT DATE. Principal of and interest due on this bond will be paid to the REGISTERED OWNER by the City or its designated paying agent and will be credited to the participants of The Depository Trust Company as listed on the records of The Depository Trust Company as of the RECORD DATES next preceding the respective INTEREST PAYMENT DATES. The principal of and interest on this bond are payable in lawful money of the United States of America.

This bond is not transferable as to principal or interest except to an authorized nominee of The Depository Trust Company. The Depository Trust Company shall be responsible for maintaining the book-entry system for recording the interests of its participants or the transfers of the interests among its participants. The participants are responsible for maintaining records regarding the beneficial ownership interests in the bonds on behalf of individual purchasers.

This bond is one of an authorized issue of bonds issued pursuant to the Local Bond Law of the State of New Jersey and bond ordinance #MC-5110 of the City finally adopted on May 18, 2018 and providing for traffic and infrastructure improvements, in all respects duly approved and published as required by law.

The full faith and credit of the City are hereby irrevocably pledged for the punctual payment of the principal of and interest on this bond according to its terms.

It is hereby certified and recited that all conditions, acts and things required by the Constitution or statutes of the State of New Jersey to exist, to have happened or to have been performed precedent to or in the issuance of this bond exist, have happened and have been performed, and that the issue of bonds of which this is one, together with all other indebtedness of the City, is within every debt and other limit prescribed by such Constitution or statutes.

IN WITNESS WHEREOF, the CITY OF CAMDEN has caused this bond to be executed in its name by the manual or facsimile signatures of its Mayor and its Chief Financial Officer, its corporate seal to be hereunto imprinted or affixed, this bond and the seal to be attested by the manual signature of its City Clerk, and this bond to be dated the DATED DATE as specified above.

CITY OF CAMDEN

[CITY SEAL]

By: [executed upon issuance]
Mayor

ATTEST:

By: [executed upon issuance]
City Clerk

By: [executed upon issuance]
Director of Finance/Chief
Financial Officer

[End of Form of Bond]

Section 5. (a) The Bonds shall be sold on April 4, 2024, or such other date as may be determined by the Chief Financial Officer, via the "PARITY Electronic Bid System" ("PARITY") upon the terms and conditions set forth and described in the Notice of Sale for the Bonds. The Notice of Sale shall be posted on MuniHub.

(b) Pursuant to N.J.S.A. 40A:2-34, the City hereby designates the Chief Financial Officer to sell and award the Bonds in accordance with the Notice of Sale with such changes as to date or the terms as deemed advisable or necessary by Phoenix Advisors, LLC, the City's Municipal Advisor, and McManimon, Scotland & Baumann, LLC, the City's Bond Counsel, to access effectively the market for the sale of the Bonds, and such Chief Financial Officer shall report in writing the results of the sale to this City Council as required by law. The Chief Financial Officer is hereby authorized and directed, consistent with the terms of the Notice of Sale, to retain the good faith deposit of the successful bidder and to return immediately such good faith deposits, whether by wire or check, to the unsuccessful bidders.

Section 6. The Notice of Sale shall be substantially in the form attached hereto as Exhibit A with such additions, deletions and omissions as may be necessary for the City to market the Bonds, including in accordance with the requirements of the Securities Depository and PARITY. The Summary Notice of Sale shall be substantially in the form attached hereto as Exhibit B with such additions, deletions and omissions as may be necessary for the City to market the Bonds, including in accordance with the requirements of the Securities Depository and PARITY. McManimon, Scotland & Baumann, LLC is hereby directed to arrange for the publication of the Notice of Sale authorized in Exhibit A in the form provided herein in an authorized newspaper of the City. McManimon, Scotland & Baumann, LLC is hereby directed to arrange for the publication of the Summary Notice of Sale authorized in Exhibit B in the form provided herein in The Bond Buyer, a financial newspaper published and circulating in the City of New York, New York, such publication to be not less than seven days prior to the date of sale.

Section 7. The Bonds shall have printed thereon a copy of the written opinion with respect to the Bonds that is to be rendered by the law firm of McManimon, Scotland & Baumann, LLC, complete except for omission of its date.

Section 8. The law firm of McManimon, Scotland & Baumann, LLC is hereby authorized to arrange for the printing of the Bonds and the Official Statement to be prepared by McManimon, Scotland & Baumann, LLC, Phoenix Advisors, LLC and City officials. The Mayor and the Chief Financial Officer are hereby authorized to execute any certificates necessary in

connection with the distribution of the Official Statement. Such Official Statement may be distributed in preliminary form and deemed final for purposes of Rule 15c2-12 of the Securities and Exchange Commission on behalf of the City by the Chief Financial Officer or by the Mayor. Final Official Statements shall be delivered to the purchaser of the Bonds within the earlier of seven business days following the sale of the Bonds or to accompany the purchaser's confirmations that request payment for the Bonds.

Section 9. The City hereby covenants that it will comply with any conditions subsequently imposed by the Internal Revenue Code of 1986, as amended, in order to preserve the exemption from taxation of interest on the Bonds, including the requirement to rebate all net investment earnings on the gross proceeds above the yield on the Bonds, if necessary.

Section 10. (a) The Chief Financial Officer is hereby authorized to make representations and warranties, to enter into agreements and to make all arrangements with the Securities Depository as may be necessary in order to provide that the Bonds will be eligible for deposit with the Securities Depository and to satisfy any obligation undertaken in connection therewith.

(b) In the event that the Securities Depository may determine to discontinue providing its service with respect to the Bonds or is removed by the City and if no successor securities depository is appointed, the Bonds that were previously issued in book-entry form shall be converted to registered Bonds in denominations of \$5,000. The beneficial owner under the book-entry system, upon registration of the Bonds held in the beneficial owner's name, will become the registered owner of the registered Bonds. The City shall be obligated to provide for the execution and delivery of the registered Bonds in certificated form.

Section 11. Solely for purposes of complying with Rule 15c2-12 of the Securities and Exchange Commission, as amended and interpreted from time to time (the "Rule"), and provided that the Bonds are not exempt from the Rule and provided that the Bonds are not exempt from the following requirements in accordance with paragraph (d) of the Rule, for so long as the Bonds remain outstanding (unless the Bonds have been wholly defeased), the City shall provide for the benefit of the holders of the Bonds and the beneficial owners thereof:

(a) On or prior to September 30 of each year, beginning September 30, 2025 for the fiscal year ending December 31, 2024, electronically to the Municipal Securities Rulemaking Board's Electronic Municipal Market Access ("EMMA") system or such other repository designated by the Securities and Exchange Commission to be an authorized repository for filing secondary market disclosure information, if any, annual financial information with respect to the City consisting of the audited financial statements (or unaudited financial statements if audited

financial statements are not then available, which audited financial statements will be delivered when and if available) of the City and certain financial information and operating data, consisting of (i) City and overlapping indebtedness, including a schedule of outstanding debt issued by the City, (ii) property valuation information and (iii) tax rate, levy and collection data. The audited financial information will be prepared in accordance with generally accepted accounting principles as modified by governmental accounting standards as may be required by New Jersey law.

(b) If any of the following events occur regarding the Bonds, a timely notice not in excess of ten business days after the occurrence of such event sent to EMMA:

- (1) Principal and interest payment delinquencies;
- (2) Non-payment related defaults, if material;
- (3) Unscheduled draws on debt service reserves reflecting financial difficulties;
- (4) Unscheduled draws on credit enhancements reflecting financial difficulties;
- (5) Substitution of credit or liquidity providers, or their failure to perform;
- (6) Adverse tax opinions, the issuance by the Internal Revenue Service of proposed or final determinations of taxability, Notices of Proposed Issue (IRS Form 5701-TEB) or other material notices or determinations with respect to the tax status of the Bonds, or other material events affecting the tax status of the Bonds;
- (7) Modifications to the rights of holders of the Bonds, if material;
- (8) Bond calls, if material, and tender offers;
- (9) Defeasances;
- (10) Release, substitution or sale of property securing repayment of the Bonds, if material;
- (11) Rating changes;
- (12) Bankruptcy, insolvency, receivership or similar event of the City;
- (13) The consummation of a merger, consolidation or acquisition involving the City or the sale of all or substantially all of the assets of the City, other than in the ordinary course of business, the entry into a definitive agreement to undertake such an action or the termination of a definitive agreement relating to any such actions, other than pursuant to its terms, if material;
- (14) Appointment of a successor or additional trustee or the change of name of a trustee, if material;
- (15) Incurrence of a Financial Obligation of the City, if material, or agreement to covenants, events of default, remedies, priority rights or other similar terms of a Financial Obligation, any of which affect holders of the Bonds, if material; and
- (16) Default, event of acceleration, termination event, modification of terms or other similar events under a Financial Obligation of the City, if any such event reflects financial difficulties.

The term "Financial Obligation" as used in subparagraphs (b)(15) and (b)(16) above means a (i) debt obligation, (ii) derivative instrument entered into in connection with, or pledged as security or a source of payment for, an existing or planned debt obligation or (iii) guarantee of (i) or (ii); *provided, however*, that the term "Financial Obligation" shall not include municipal securities as to which a final official statement has been provided to the Municipal Securities Rulemaking Board consistent with the Rule.

(c) Notice of failure of the City to provide required annual financial information on or before the date specified in this resolution shall be sent in a timely manner to EMMA.

If all or any part of the Rule ceases to be in effect for any reason, then the information required to be provided under this resolution, insofar as the provisions of the Rule no longer in effect required the provision of such information, shall no longer be required to be provided.

The Chief Financial Officer shall determine, in consultation with Bond Counsel, the application of the Rule or the exemption from the Rule for each issue of obligations of the City prior to their offering. Such Chief Financial Officer is hereby authorized to enter into additional written contracts or undertakings to implement the Rule and is further authorized to amend such contracts or undertakings or the undertakings set forth in this resolution, provided such amendment is, in the opinion of nationally recognized bond counsel, in compliance with the Rule.

In the event that the City fails to comply with the Rule requirements or the written contracts or undertakings specified in this resolution, the City shall not be liable for monetary damages. The sole remedy is hereby specifically limited to specific performance of the Rule requirements or the written contracts or undertakings therefor.

Section 12. This resolution shall take effect immediately.

BE IT FURTHER RESOLVED, that pursuant to N.J.S.A. 52:27BBB-23, a true copy of this Resolution shall be forwarded to the State Commissioner of Community Affairs, who shall have ten (10) days from the receipt thereof to veto this Resolution. All notices of veto shall be filed in the Office of the Municipal Clerk.

Date: March 12, 2024

The above has been reviewed
and approved as to form



DANIEL S. BLACKBURN
City Attorney

ANGEL FUENTES
President, City Council

ATTEST: _____
LUIS PASTORIZA
Municipal Clerk

CERTIFICATE

I, Luis Pastoriza, Clerk of the City of Camden, in the County of Camden, New Jersey, HEREBY CERTIFY that the foregoing resolution is a true, complete and correct copy of a resolution duly adopted at a meeting of the governing body of the City duly called and held on March 12, 2024 in accordance with the New Jersey Open Public Meetings Act as set forth in the minutes as officially recorded in my office in the Minute Book of the governing body, and that the resolution has not been amended or repealed, remains in full force and effect and was duly adopted by the vote set forth below.

AYES:

NAYS:

ABSTENTIONS:

ABSENCES:

IN WITNESS WHEREOF, I have hereunto set my hand and affixed the corporate seal of the City this ____ day of _____, 2024.

Luis Pastoriza, Clerk

[SEAL]

Exhibit A

**(Notice of Sale to be Posted on MuniHub and
Published in Local Newspaper)**

NOTICE OF SALE
\$2,000,000* GENERAL IMPROVEMENT BONDS, SERIES 2024,
OF THE
CITY OF CAMDEN, IN THE COUNTY OF CAMDEN, NEW JERSEY
(Book-Entry-Only Bonds) (Non-callable) (Not Bank-Qualified)

SUMMARY

ISSUER: City of Camden, in the County of Camden, New Jersey

PAR AMOUNT: \$2,000,000*

SECURITY: General obligations of the City

TAX-EXEMPT: Yes

RATING: Rating to be assigned.

TYPE OF SALE: Electronic proposals via PARITY Electronic Bid System (PARITY) of I-Deal, LLC ("I-Deal"). See "Bidding Details" herein.

AGENT: PARITY – Electronic proposals will be received via the PARITY Electronic Bid System ("PARITY") of I-Deal

SALE DATE & BID TIME: April 4, 2024 until 11:00 a.m. local time, at which time they will be publicly opened, received and announced. Award by 3:00 p.m.

DATED DATE: Date of Delivery

DELIVERY DATE: April 25, 2024

INTEREST PAYMENT DATES: April 1 and October 1, commencing October 1, 2024

CALL DATE: Non-callable

MINIMUM BID: \$2,000,000 (Par)

MAXIMUM BID: \$2,140,000 (Par plus 7% original issue premium)

BID SECURITY: **Good Faith Check or wire transfer in the amount of \$40,000 received by City (prior to bidding) or Financial Surety Bond from Sure-Bid**

BASIS OF AWARD: True Interest Cost

LEGAL OPINION: McManimon, Scotland & Baumann, LLC, Roseland, New Jersey

OFFERING STATEMENT: Preliminary Official Statement available at www.munihub.com

*Preliminary, subject to change.

NOTICE

NOTICE IS HEREBY GIVEN that bids will be received by the City of Camden, in the County of Camden, New Jersey (the "City"), for the purchase of \$2,000,000* original principal amount of the City's General Improvement Bonds, Series 2024 (the "Bonds"). **All Bids (as defined below) must be submitted in their entirety via "PARITY Electronic Bid System" (PARITY) prior to 11:00 a.m., New Jersey time, on April 4, 2024 (the "Sale Date"). To bid, Bidders (as defined below) must have submitted a good faith check, wire or Financial Surety Bond, if available, payable to the City, in the amount of \$40,000 by no later than 10:30 a.m. on the Bid Date (see Bidding Details below).**

Preliminary and Final Official Statements

The City's Preliminary Official Statement (the "POS") is available for viewing in electronic format on MuniHub's website located at www.munihub.com. In addition, broker-dealers registered with the Financial Industry Regulatory Authority and dealer banks with The Depository Trust Company ("DTC") clearing arrangements may either: (a) print out a copy of the POS on their own printer or (b) at any time prior to the Sale Date, elect to receive a photocopy of the POS in the mail by requesting it by calling the City's bond counsel, Christopher B. Langhart, Esq., of McManimon, Scotland & Baumann, LLC ("Bond Counsel"), 75 Livingston Avenue, Roseland, New Jersey 07068 (telephone no. 973-622-4855), or attention of Terry Anderson, Paralegal (telephone no. 973-622-5161), or the City's Municipal Advisor, Bryan Morris of Phoenix Advisors, LLC (the "Municipal Advisor"), 625 Farnsworth Avenue, Bordentown, New Jersey 08505 (telephone no. 609-291-0130). All Bidders must review the POS and certify that they have done so prior to participating in the bidding.

The POS is deemed by the City to be final as of its date for purposes of SEC Rule 15c2-12(b)(1) under the Securities Exchange Act of 1934, except for the omission of information concerning the offering price(s), interest rate(s), selling compensation, aggregate principal amount of the Bonds and any other terms or provisions to be determined from the successful Bid(s) or depending on such matters, and the identity of the underwriter(s). The POS is, however, subject to such further revisions, amendments and completion in a Final Official Statement (the "Final Official Statement") as may be necessary.

The City, at its own expense, will make available to the winning Bidder a reasonable number of Final Official Statements within seven (7) business days following the date of acceptance of the Bid.

Types of Bids Allowed

Subject to the Bid requirements described below, Bids for the Bonds must be submitted on an "All-or-None" ("AON") basis for the entire amount of \$2,000,000*. There will be only one CUSIP assigned to each annual maturity of the issue. First, a Bidder must submit a conforming Bid for the entire issue, and if such Bid is accepted by the City, such winning Bidder will be required to purchase the entire issue in accordance with such Bid.

*Preliminary, subject to change.

Interest Payment Dates; Description of the Bonds

The Bonds will be dated their date of delivery and will bear interest from such date payable semiannually on each April 1 and October 1, commencing on October 1, 2024. Interest shall be computed on the basis of a 30-day month/360-day year.

Principal Amortization

The Bonds shall mature on April 1 as set forth in the following table:

<u>Year</u>	<u>Principal Amount</u>	<u>Year</u>	<u>Principal Amount</u>
2025	\$250,000	2028	\$500,000
2026	250,000	2029	500,000
2027	500,000		

The City may, and expects to, after the receipt and opening of bids, adjust the maturity schedule of the Bonds; *provided, however*, that (i) no maturity schedule adjustment shall exceed 10% upward or downward of the principal for any maturity as specified herein, and (ii) the aggregate adjustment to the maturity schedule shall not exceed 10% upward or downward of the aggregate principal amount of Bonds, as specified herein, and the aggregate principal amount of Bonds, as adjusted, will not exceed \$2,000,000. The dollar amount bid by the winning bidder shall be adjusted to reflect any adjustments in the aggregate principal amount of the Bonds to be issued. The adjusted Bid price will reflect changes in the dollar amount of the underwriter's discount and the original issue premium or discount, but will not change the per bond underwriter's discount, as calculated from the original Bid, and the initial public offering prices required to be delivered to the City, as stated herein.

Book-Entry-Only

The Bonds will be issued in book-entry-only form, initially in the name of Cede & Co., as nominee for DTC. Purchasers will not receive certificates representing their interests in the Bonds. Individual purchases will be in the principal amount of \$5,000 or any integral multiple of \$1,000 in excess thereof. Payments of principal, interest and redemption premium, if any, will be made by the paying agent to DTC for subsequent disbursement to DTC participants to then be remitted to the beneficial owners of the Bonds.

Section 265 Qualification

The Bonds will not be designated as qualified under Section 265 of the Internal Revenue Code of 1986, as amended, by the City for an exemption from the denial of deduction for interest paid by financial institutions to purchase or to carry tax-exempt obligations.

Redemption Provisions

The Bonds of this issue are not subject to redemption prior to their stated maturities.

Term Bond Option – Not Available

Terms of PARITY

Each electronic proposal must be submitted via PARITY. No bidder will see any other bidder's Bid, nor will any bidder see the status of its Bid relative to other Bids (*e.g.*, whether its Bid is a leading bid). To the extent any instructions or directions set forth on PARITY conflict with this Notice of Sale, the terms of this Notice of Sale shall control. For further information about PARITY, potential bidders may contact PARITY at I-Deal at (212) 404-8102. The City may, but is not obligated to, acknowledge its acceptance in writing of any Bid submitted electronically via PARITY. If a Bid submitted electronically via PARITY is accepted by the City, the terms of this Notice of Sale and the information that is electronically transmitted via PARITY shall form a contract, and the successful bidder shall be bound by the terms of such contract.

PARITY is not an agent of the City, and the City shall have no liability whatsoever based on any bidder's use of PARITY, including, but not limited to, any failure by PARITY to correctly or timely transmit information provided by the City or information provided by the bidder.

The City may choose to discontinue use of electronic bidding via PARITY by issuing a notification to such effect via TM3 News Services, or by other available means, no later than 10:00 a.m., Eastern Time, on the Sale Date.

Once the bids are communicated electronically via PARITY to the City, each Bid will constitute an official proposal for the Bonds and shall be deemed to be an irrevocable offer to purchase the Bonds on the terms provided in this Notice of Sale. For purposes of submitting all proposals for the Bonds, the time as maintained on PARITY shall constitute the official time.

Each bidder shall be solely responsible to make necessary arrangements to access PARITY for purposes of submitting its Bid in a timely manner and in compliance with the requirements of this Notice of Sale. Neither the City nor i-Deal shall have any duty or obligation to provide or assure access to any bidder, and neither the City nor i-Deal shall be responsible for the proper operation of, or have any liability for any delays or interruptions of, or any damages caused by, PARITY. The City is using PARITY as a communication mechanism, and not as the City's agent, to conduct the electronic bidding for the Bonds. By using PARITY, each bidder agrees to hold the City harmless for any harm or damages caused to such bidder in connection with its use of PARITY for bidding on the Bonds.

Bidding Details

Bidders should be aware of the following bidding details associated with the sale of the Bonds:

- (1) **BIDDERS MUST SUBMIT A GOOD FAITH CHECK, WIRE TRANSFER OR A FINANCIAL SURETY BOND IN THE AMOUNT OF \$40,000 PAYABLE TO THE CITY NO LATER THAN 10:30 A.M. ON THE SALE DATE. HOWEVER, BIDDERS ARE ENCOURAGED TO SUBMIT CHECKS OR WIRES ON THE DAY PRIOR TO THE SALE DATE TO ASSURE RECEIPT OF PAYMENT BY THE CITY AT THE FOLLOWING ADDRESS:**

Gerald C. Seneski
Chief Financial Officer
City of Camden
520 Market Street, Room 213
Camden, NJ 08101

BIDDERS SUBMITTING GOOD FAITH CHECKS SHOULD ALSO ENCLOSE A RETURN ENVELOPE FOR USE BY THE CITY. BIDDERS SUBMITTING A WIRE SHOULD CONTACT THE CITY'S MUNICIPAL ADVISOR, BRYAN MORRIS (TELEPHONE NO. 609-291-0130), TO OBTAIN THE WIRE INSTRUCTIONS.

UNSUCCESSFUL BIDDERS SUBMITTING THE GOOD FAITH DEPOSIT BY WIRE TRANSFER SHALL, NO LATER THAN THE CLOSE OF BUSINESS ON THE SALE DATE OF THE BONDS, PROVIDE THE CHIEF FINANCIAL OFFICER IN WRITING WITH WIRING INSTRUCTIONS FOR THE RETURN OF SUCH UNSUCCESSFUL BIDDER'S GOOD FAITH DEPOSIT. IN THE EVENT THAT THE CITY FAILS TO RETURN ANY GOOD FAITH WIRES IN A TIMELY FASHION, THE CITY SHALL NOT BE LIABLE FOR MONETARY DAMAGES, REMEDY BEING HEREBY SPECIFICALLY LIMITED TO SPECIFIC PERFORMANCE.

- (2) All Bids must be submitted on PARITY. **No telephone, telefax, telegraph or personal delivery Bids will be accepted.**
- (3) All Bids for the Bonds must be submitted on an AON basis. Bidders may change and submit Bids as provided for herein, but a submitted Bid may not be withdrawn.
- (4) Bidders may bid to purchase Bonds from the City with a bid premium in an amount not in excess of seven percent (7%) of the par amount of the Bonds, representing a bid price of not in excess of \$2,140,000. No Bid will be considered if the Bid is to purchase Bonds at a price less than 100% of the principal amount thereof. The City may, and expects to, after the receipt and opening of bids, adjust the maturity schedule of the Bonds as set forth in more detail under "Principal Amortization" above.
- (5) Each proposal submitted must name the rate or rates of interest per annum to be borne by the Bonds and the rate or rates named must be multiples of 1/8 or 1/20 of 1%. The difference between the highest and lowest interest rates named in the Bid shall not exceed two percent (2%) per annum. Not more than one rate may be named for Bonds of the same maturity. There is no limitation on the number of rates that may be named. Each proposal submitted must state the purchase price, which must be not less than par. The Bonds will be awarded to the bidder on whose Bid the total loan may be made at the lowest true interest cost ("TIC"). Such TIC shall be calculated as described below. No proposal shall be considered that offers to pay an amount less than the principal amount of Bonds offered for sale or under which the total loan is made at a TIC higher than the lowest TIC to the City under any legally acceptable proposal. The purchaser must also pay an amount equal to the interest on the Bonds accrued to the date of payment of the purchase price, if applicable.
- (6) Bidders are only permitted to submit Bids for the Bonds during the bidding period.

Definitions

"Bid"	any confirmed purchase offer received by PARITY on or before the proposal submission deadline.
"Bidder"	any firm registered and approved for participation in sale.
"True Interest Cost (TIC)"	true interest cost shall be computed in each instance by determining the interest rate, compounded semi-annually, necessary to discount the debt service payments to the date of the bonds and to the price bid, excluding interest accrued to the Delivery Date. The TIC serves as the basis for awarding bonds to the winning bidder.
"Winning Bid"	any purchase offer made by a bidder and received by PARITY that, at the end of the bidding time period, results in the lowest TIC that is acceptable to the City.

Bid Procedure and Basis of Award

Subject to the right reserved by the City to reject any or all Bids, the Bonds will be sold to the bidder whose Bid produces the lowest TIC for the City and otherwise complies with the Notice of Sale.

Bids must remain valid until at least 3:00 p.m., prevailing time, on the Sale Date, and if accepted by the City, prior to such time, shall be irrevocable except as otherwise provided in the Notice of Sale. Upon selection of the winning bidder, the City will execute an award certificate to award the Bonds and will promptly communicate with the winning bidder by telephone, e-mail or fax.

Bid Security and Method of Payment for Bonds

A good faith deposit (the "Deposit") in the form of a certified or cashier's check, wire transfer (wiring instructions can be obtained from the City's Municipal Advisor) or a Financial Surety Bond in the amount of \$40,000, payable to the order of the City, is required for each Bid to be considered. If a check is used, it must be a certified treasurer's or cashier's check and must be provided to the City prior to 10:30 a.m. on the Sale Date for bids to be submitted. If a wire transfer is used, such wire must be received by the City prior to 10:30 a.m. on the Sale Date. Each bidder accepts responsibility for delivering such check or wire on time and the City is not responsible for any check or wire that is not received on time. If a Financial Surety Bond is used, it must be from an insurance company licensed to issue such a bond in the State of New Jersey and approved by the Director of the Division of Local Government Services of New Jersey (the "Director") and such bond must be submitted to the City prior to 10:30 a.m. on the Sale Date at the address referred to above. At present, the Director has approved the use of Sure-Bid, a division of Financial Security Assurance Inc. Use of any other Financial Surety Bond must be approved by the Director prior to the Bid and will not be accepted by the City unless evidence of such approval is provided prior to the Bid. The Financial Surety Bond must identify the bidder whose Deposit is guaranteed by such Financial Surety Bond. If the Bonds are awarded to a bidder utilizing a Financial Surety Bond, then that winning bidder is required to submit its Deposit to the City by wire transfer as instructed by the City not later than 3:30 p.m. on the next business day following the Sale Date. If such Deposit is not received by that time, the Financial Surety Bond may be drawn by the City to satisfy the Deposit requirement. No

interest on the Deposit will accrue to the winning bidder. The Deposit will be applied to the purchase price of the Bonds. In the event the winning bidder fails to honor its accepted Bid, the Deposit will be retained by the City. Award of the Bonds to the winning bidder or rejection of all Bids is expected to be made within two hours after opening of the bids, but such winning bidder may not withdraw its proposal until after 3:00 p.m. on the Sale Date and then only if such award has not been made prior to the withdrawal. The balance of the purchase price shall be paid in federal funds by wire transfer to the City on or about the Delivery Date.

Right to Reject Bids; Waive Irregularities

The City reserves the right to reject any and all Bids and, to the extent permitted by law, to waive any irregularity or informality in any Bid.

Information Required from the Winning Bidder

By making a bid for the Bonds, the winning bidder(s) agrees: (a) to provide to the City, in writing, immediately upon being unofficially awarded the Bonds, a written confirmation of the Bid, which shall include the purchase price, reoffering yield(s) and other related information necessary for completion of the Final Official Statement by the Municipal Advisor and by Bond Counsel; (b) to disseminate to all members of the underwriting syndicate copies of the Final Official Statement; (c) to promptly file a copy of the Final Official Statement with the Municipal Securities Rulemaking Board; and (d) to take any and all other actions necessary to comply with applicable Securities and Exchange Commission and Municipal Securities Rulemaking Board rules governing the offering, sale and delivery of the Bonds to alternate purchasers.

Establishment of Issue Price for the Bonds

In the event the City receives at least three (3) bids for the Bonds, then the issue price for the Bonds shall be established based on the reasonably expected initial offering prices of the Bonds as of the Sale Date (the "Expected Offering Prices"). The Expected Offering Prices shall consist of the prices for each maturity of the Bonds used by the winning bidder in formulating its bid to purchase the Bonds. The winning bidder shall be required to deliver on the Delivery Date a certificate to such effect and to provide to the City, in writing, the Expected Offering Prices as of the Sale Date.

In the event the City receives fewer than three (3) bids for the Bonds, then the issue price for the Bonds shall be established based on the following method as selected by the winning bidder on the Sale Date:

10% Sold: The issue price for the Bonds shall be established based on the first price at which at least 10% of each maturity of the Bonds was sold to the Public (as defined below). The winning bidder shall be required to deliver on the Delivery Date a certificate to such effect and to provide to the City, in writing, evidence satisfactory to Bond Counsel to the City of such sales prices for each maturity of the Bonds. In the event that the winning bidder has not sold at least 10% of each maturity of the Bonds to the Public as of the Delivery Date (each, an "Unsold Maturity"), the winning bidder shall (i) provide to the City, in writing, on the Delivery Date, the Expected Offering Prices for each Unsold Maturity and a certificate regarding same and (ii) have a continuing obligation to provide to the City, in writing, evidence satisfactory to Bond Counsel to the City of the first price at which at least 10% of each Unsold Maturity is sold to the Public, contemporaneous with each such sale, until at least 10% of all such Unsold Maturities have been sold to the Public.

Hold-the-Price: The issue price for the Bonds shall be established based on the initial offering price of the Bonds to the Public as of the Sale Date, provided that the winning bidder shall, in writing, (i) confirm that the Underwriters have offered or will offer the Bonds to the public on or before the Sale Date at the offering price or prices set forth in the Bid submitted by the Winning Bidder and (ii) agree, on behalf of the Underwriters participating in the purchase of the Bonds, that the Underwriters will neither offer nor sell the Bonds to any person at a price that is higher than the initial offering price to the Public during the period starting on the Sale Date and ending on the earlier of: (1) the close of the fifth (5th) business day after the sale date or (2) the date on which the Underwriters have sold at least 10% of the Bonds to the Public at a price that is no higher than the initial offering price to the Public.

Public means any person (including an individual, trust, estate, partnership, association, company or corporation) other than an Underwriter (as defined herein) or a related party to an Underwriter. The term "related party" generally means any two or more persons who have greater than 50% common ownership, directly or indirectly. Underwriter means (i) any person that agrees pursuant to a written contract with the Issuer (or with the lead underwriter to form an underwriting syndicate) to participate in the initial sale of the Bonds to the Public, and (ii) any person that agrees pursuant to a written contract directly or indirectly with a person described in clause (i) of this paragraph to participate in the initial sale of the Bonds to the Public (including a member of a selling group or a party to a third-party distribution agreement participating in the initial sale of the Bonds to the Public).

Delivery of the Bonds

The Bonds will be delivered on or about the Delivery Date (UNLESS A NOTICE OF A CHANGE IN THE DELIVERY DATE IS PUBLISHED ON MUNIAUCTION NOT LATER THAN 2 HOURS PRIOR TO ANY ANNOUNCED DATE FOR RECEIPT OF BIDS) in New York City at DTC against payment of the purchase price therefor (less the amount of the good faith deposit) in federal funds.

There will also be furnished the usual closing papers, including (1) a certificate signed by the officials who signed the Bonds stating that no litigation of any kind is now pending or, to their knowledge, threatened to restrain or enjoin the issuance or delivery of the Bonds, or in any manner questioning the proceedings and authorization under which the Bonds are issued or affecting the validity of the Bonds, and (2) a certificate signed by the City relating to the Final Official Statement.

CUSIP Numbers

The Municipal Advisor will apply for CUSIP numbers with respect to the Bonds, but neither the Municipal Advisor nor the City will assume any obligation for the assignment or printing of such numbers on the Bonds or for the correctness of such numbers, and neither the failure to print such numbers on any Bond nor any error with respect thereto shall constitute cause for a failure or refusal by the winning bidder to accept delivery of and make payment for the Bonds. The CUSIP Service Bureau charge for the assignment of the CUSIP numbers shall be the responsibility of and shall be paid for by the winning bidder.

Legal Opinion

The approving opinion of Bond Counsel will be furnished without cost to the winning bidder.

Postponement

The City reserves the right to postpone, from time to time, the date and time established for receipt of Bids. **ANY SUCH POSTPONEMENT WILL BE PUBLISHED OR POSTED, BEFORE 10:00 A.M. ON THE SALE DATE.** If any date fixed for the receipt of Bids and the sale of the Bonds is postponed, an alternative sale date will be announced via PARITY at least forty-eight (48) hours prior to such alternative sale date. On any such alternative sale date, any bidder may submit a Bid for the purchase of the Bonds in conformity in all respects with the provisions of the Notice of Sale, except for the date of sale and except for the changes announced on PARITY at the time the sale date and time are announced.

Additional Information

For further information relating to the Bonds, reference is made to the POS prepared for and authorized by the City. The Notice of Sale and the POS may be viewed on MuniHub's website located at www.munihub.com. However, the City makes no assurance or representation with respect to the form of the Notice of Sale and the POS on MuniHub, and no investment decision should be made in reliance thereon. Printed copies of the POS and the Notice of Sale may be obtained from the Municipal Advisor or Bond Counsel at the addresses and phone numbers stated above. For additional information relating to the sale, please contact PARITY at (212) 404-8102. Additional information relating to the financing by the City can be obtained by contacting the undersigned Chief Financial Officer at (856) 757-7261 or at Gesenesk@ci.camden.nj.us or by contacting the City's Municipal Advisor.

CITY OF CAMDEN

By: Gerald C. Seneski, Chief Financial Officer

Dated: _____, 2024

Exhibit B

(Summary Notice of Sale to be Published in The Bond Buyer)

SUMMARY NOTICE OF SALE

\$2,000,000*
GENERAL IMPROVEMENT BONDS, SERIES 2024,
OF THE CITY OF CAMDEN, IN THE
COUNTY OF CAMDEN, NEW JERSEY
(Book-Entry-Only Bonds) (Non-callable) (Not Bank-Qualified)

SUMMARY

Dated: Date of Delivery – On or about April 25, 2024

Bid Date and Time: April 4, 2024 at 11:00 a.m. and award by 3:00 p.m.

Type of Sale: PARITY

Interest: Multiple Interest Rates – multiples of 1/8 or 1/20 of 1%

Legal Opinion: McManimon, Scotland & Baumann, LLC, Roseland, NJ

Bid Security: Good faith check, wire transfer or Financial Surety Bond must be received by the City by 10:30 a.m. prior to bidding in the amount of \$40,000

Limitation on Premium: \$2,140,000 (Par plus 7% original issue premium)

Maturity Schedule: April 1 as set forth in the following table:

<u>Year</u>	<u>Principal Amount</u>	<u>Year</u>	<u>Principal Amount</u>
2025	\$250,000	2028	\$500,000
2026	250,000	2029	500,000
2027	500,000		

* Preliminary, subject to change

Preliminary Official Statement, Notice of Sale and other details available at www.munihub.com



CITY OF CAMDEN — CITY COUNCIL ACTION REQUEST FORM

COUNCIL MEETING DATE: MARCH 12, 2024

TO: City Council
FROM: Gerald C. Seneski

TITLE OF ORDINANCE/RESOLUTION: RESOLUTION DETERMINING THE FORM AND OTHER DETAILS OF \$2,000,000 GENERAL IMPROVEMENT BONDS, SERIES 2024, OF THE CITY OF CAMDEN, IN THE COUNTY OF CAMDEN, NEW JERSEY, AND PROVIDING FOR THEIR SALE.

Point of Contact:	Gerald C. Seneski	Finance	Ext-7582	GeSenesk@ci.camden.nj.us
	Name	Department-Division-Bureau	Phone	Email

ENDORSEMENTS

	Recommend Approval (Y/N)	Signature	Date	Comments
Responsible Department Director	N		2/15	
Supporting Department Director (if necessary)	N			
Director of Grants Management	N			
Qualified Purchasing Agent	N			
Director of Finance	Y		2/15	

Approved by:
Business Administrator

Signature

2/22
Date

Attachments (list and attach all available):

Resolution

"Walk-on" note: All walk-on legislation must be pre-approved by the Business Administrator. The Department Director and Contact Person are jointly responsible for delivering all necessary documents to the City Clerk for distribution at the Council Meeting.

Received by:
City Attorney

Signature

Date

EXECUTIVE SUMMARY

TITLE OF ORDINANCE/RESOLUTION: RESOLUTION DETERMINING THE FORM AND OTHER DETAILS OF \$2,000,000 GENERAL IMPROVEMENT BONDS, SERIES 2024, OF THE CITY OF CAMDEN, IN THE COUNTY OF CAMDEN, NEW JERSEY, AND PROVIDING FOR THEIR SALE.

FACTS/BACKGROUND:

- See Attached Resolution.

AMOUNT OF PROPOSED CONTRACT or TOTAL COST OF PROPOSAL: \$2,000,000

IMPACT STATEMENT:

- What will happen if the City Council approves this legislation?
 - The City will be able to fund various general improvements throughout the City
- Why Should the City Council approve this legislation?
 - This resolution Is required in order to receive financing

SUBJECT MATTER EXPERTS/ADVOCATES:

Gerry C. Seneski, CFO

Prepared by: Scott Z. Parker

(856) 757-6405

Name

Phone/Email

MS

City of Camden - Board of Finance - February 14, 2024

February 14, 2024

Gerald C. Seneski
Chief Financial Officer
City of Camden
520 Market Street
Camden, NJ 08101

Re: \$2,000,000 General Improvement Bonds, Series 2024

Dear Gerry:

In connection with the proposed electronic bond sale scheduled for April 4, 2024 for the above-referenced bonds, we have prepared and enclose herewith the following:

1. Tentative timetable;
2. Form of resolution to be adopted by the City Council at a meeting to be held March 12, 2024 determining the form and other details of the \$2,000,000 General Improvement Bonds, Series 2024, and providing for their sale. I will need one executed copy of the resolution for my file; and
3. Bond ordinance chart. Please complete and return the chart to me.

Bowman & Company, LLP will prepare and circulate a draft Preliminary Official Statement. Phoenix Advisors, LLC will apply for a rating. Our firm will arrange for the publication and posting of the required notices in connection with the bond sale. If you have any questions after you have had a chance to review the documents, please call me.

Very truly yours,

Christopher B. Langhart

Christopher B. Langhart

CBL/ta

Enclosures

cc: Luis Pastoriza, City Clerk, w/encl.
Daniel S. Blackburn, Esq., w/encl.
Jennifer L. Bertino, CPA, RMA, w/encl.
Sharon Branco, w/encl.
Anthony P. Inverso, w/encl.
Bryan Morris, w/encl.
Clifford Horner, w/encl.

A-29

DB:dh
03-12-24

**RESOLUTION AUTHORIZING THE CANCELLATION OF LIENS/TAXES AND TO
TRANSFER CREDITS TO VARIOUS LIEN HOLDERS, PROPERTY OWNERS,
AND MORTGAGE COMPANIES FOR VARIOUS PROPERTIES**

WHEREAS, the individuals or business organizations listed below overpaid, made duplicate payments, are tax exempt, or are otherwise due refunds resulting from transactions with the City of Camden; and

WHEREAS, the Tax Collector has verified that the overpayments, duplications of payments, or unapplied cash are valid and the individuals or business organizations listed below are due refunds; and

WHEREAS, the Tax Collector has verified that the applicable properties are tax exempt; and

WHEREAS, the Tax Collector has requested that City Council authorize her to take the action listed below; now, therefore

BE IT RESOLVED, by the City Council of the City of Camden that the Tax Collector is hereby authorized take the following actions:

Name	Reason
Isaiah Troutman – Life Est 1275 Carl Miller Blvd Camden NJ 08104	Cancel Certificate #23-01535 and add tax and board-up charges to open municipal lien certificate #22-01358 1275 Carl Miller Blvd B/L 1362/113

BE IT FURTHER RESOLVED, that pursuant to N.J.S.A. 52:27BBB-23, a true copy of this Resolution shall be forwarded to the State Commissioner of Community Affairs, who shall have ten (10) days from the receipt thereof to veto this Resolution. All notices of veto shall be filed in the Office of the Municipal Clerk.

Date: March 12, 2024

The above has been reviewed and approved as to form.

DANIEL S. BLACKBUURN
City Attorney

ANGEL FUENTES
President, City Council

ATTEST: _____
LUIS PASTORIZA
Municipal Clerk



CITY OF CAMDEN — CITY COUNCIL ACTION REQUEST FORM

COUNCIL MEETING DATE: MARCH 12, 2024

TO: City Council
FROM: Gerald C. Seneski, Director of Finance

TITLE OF ORDINANCE/RESOLUTION: Resolution authorizing the cancellation of liens/taxes and to transfer credits to various lien holders, property owners and mortgage companies for various properties.

Point of Contact:	Lydia Laracuente	Finance-Revenue Collection	7003	LyLaracu@ci.camden.nj.us
	Name	Department-Division-Bureau	Phone	Email

ENDORSEMENTS

	Recommend Approval (Y/N)	Signature	Date	Comments
Responsible Department Director			2/21	
Supporting Department Director (if necessary)				
Director of Grants Management				
Qualified Purchasing Agent				
Director of Finance			2/21	
Approved by: Business Administrator				
		Signature	Date	

Attachments (list and attach all available):

"Walk-on" note: All walk-on legislation must be pre-approved by the Business Administrator. The Department Director and Contact Person are jointly responsible for delivering all necessary documents to the City Clerk for distribution at the Council Meeting.

Received by: City Attorney		FEB 29 2024
	Signature	Date

EXECUTIVE SUMMARY

TITLE OF ORDINANCE/RESOLUTION: Resolution authorizing the cancellation of liens/taxes and to transfer credits to various lien holders, property owners and mortgage companies for various properties.

FACTS/BACKGROUND:

Cancel and/or transfer credits on multiple properties for various reason per attached spreadsheet.

AMOUNT OF PROPOSED CONTRACT or TOTAL COST OF PROPOSAL: N/A

IMPACT STATEMENT: N/A

SUBJECT MATTER EXPERTS/ADVOCATES: N/A

COORDINATION: N/A

Prepared by:

Lydia Laboy-Laracuente

7003

LyLaracu@ci.camden.nj.us

Name

Phone/Email

TITLE OF RESOLUTION/ORDINANCE: Resolution to cancel/transfer.

BRIEF DESCRIPTION OF ACTION: Resolution authorizing the cancellation of liens/taxes and to transfer credits to various lien holders, property owners and mortgage companies for various properties. Please see attached.

Prepared by: _____ Lydia Laboy-Laracuente _____ 7003 _____

Contact Person: _____ Lydia Laboy-Laracuente _____ 7003 _____

Name	Reason
Isaiah Troutman – Life Est 1275 Carl Miller Blvd Camden NJ 08104	Cancel Certificate #23-01535 and tax and board-up charges added to open municipal lien certificate #22-01358 1275 Carl Miller Blvd B/L 1362/113

Please note that the Contact Person is the point person for providing pertinent information regarding request.
If request is a walk-on, the Contact Person will be responsible for picking up the Council request(s) from the City Attorney's Office to make necessary copies for Council Meeting.

******Please attach all supporting documents******

City of Camden
Finance Department
Bureau of Revenue Collection

**CERTIFICATION BY
THE TAX COLLECTOR**

I, as the Tax Collector, do certify that the following titled Resolution, that is attached, to be presented to Council for consideration, is correct to the best of my knowledge:

“RESOLUTION TO CANCEL/TRANSFER”

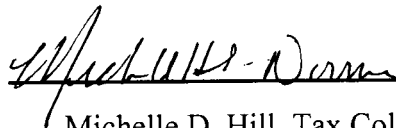
Michelle D. Hill, Tax Collector

2/16/24

Date

DB:dh
03-12-24

R-30

RESOLUTION AUTHORIZING REFUNDS TO VARIOUS LIEN HOLDERS, PROPERTY OWNERS, AND MORTGAGE COMPANIES FOR VARIOUS PROPERTIES AND ISSUANCE OF DUPLICATE TAX CERTIFICATES

WHEREAS, the individuals or business organizations listed below overpaid, made duplicate payments, or are otherwise due refunds resulting from transactions with the City of Camden; and

WHEREAS, the Tax Collector has verified that the overpayments, duplications of payments, or unapplied cash are valid and the individuals or business organizations listed below are due refunds; and

WHEREAS, the Tax Collector has received requests for the issuance of duplicate tax certificates and has received the required fees from the requestors; and

WHEREAS, the Tax Collector has requested that City Council authorize her to issue refunds to individuals and business organizations and cancel taxes as indicated below; or issue duplicate tax sale certificates as listed below; now, therefore

BE IT RESOLVED, by the City Council of the City of Camden that the Tax Collector is hereby authorized take the following actions:

Name	Amount	Reason
Fig Cust FIGN NJ19LLC 7 Sec Pty PO Box 669507 Dallas TX 75266-9507	\$1010.84	Refunding lienholder subsequent payments made on a lien 20A01018 828 Elm St B/L 801/40 which was cancelled by MC No 9047
Real Portfolio 12, LLC 216 Haddon Ave Ste. 503 Haddon Twp NJ 08108	\$446.97	Refund lienholder sub payment for 1 st qtr. 2024 for 903 N 5 th St B/L 752/66 Quarter already paid - sub payment on one check w/numerous properties

BE IT FURTHER RESOLVED, that pursuant to N.J.S.A. 52:27BBB-23, a true copy of this Resolution shall be forwarded to the State Commissioner of Community Affairs, who shall have ten (10) days from the receipt thereof to veto this Resolution. All notices of veto shall be filed in the Office of the Municipal Clerk.

Date: March 12, 2024

The above has been reviewed and approved as to form.

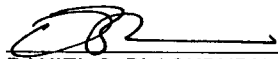
DANIEL S. BLACKBURN
City Attorney

ANGEL FUENTES
President, City Council

ATTEST: _____
LUIS PASTORIZA
Municipal Clerk



CITY OF CAMDEN — CITY COUNCIL ACTION REQUEST FORM

COUNCIL MEETING DATE: MARCH 12, 2024

TO: City Council
FROM: Gerald C. Seneski, Director of Finance
TITLE OF ORDINANCE/RESOLUTION: Resolution authorizing refunds to various lien holders, property owners and mortgage companies for various properties.

Point of Contact:	Lydia Laracuente	Finance-Revenue Collection	7003	LyLaracu@ci.camden.nj.us
	Name	Department-Division-Bureau	Phone	Email

ENDORSEMENTS

	Recommend Approval (Y/N)	Signature	Date	Comments
Responsible Department Director Supporting Department Director (if necessary) Director of Grants Management Qualified Purchasing Agent Director of Finance			2/21	
Approved by: Business Administrator			2/22	

Attachments (list and attach all available):

"Walk-on" note: All walk-on legislation must be pre-approved by the Business Administrator. The Department Director and Contact Person are jointly responsible for delivering all necessary documents to the City Clerk for distribution at the Council Meeting.

Received by: City Attorney		FEB 29 2024
	Signature	Date

City of Camden
Finance Department
Bureau of Revenue Collection

**CERTIFICATION BY
THE TAX COLLECTOR**

I, as the Tax Collector, do certify that the following titled Resolution, that is attached, to be presented to Council for consideration, is correct to the best of my knowledge:

“RESOLUTION TO REFUND”

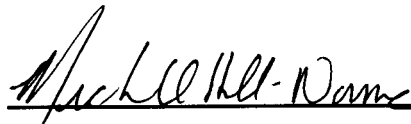

Michelle D. Hill, Tax Collector

2/16/24

Date

R-31

DB:dh
03-12-24

**RESOLUTION AUTHORIZING THE REIMBURSEMENT OF A CONSTRUCTION
PERMIT TO DEVITO'S HVAC, IN THE AMOUNT OF \$860.00**

WHEREAS, DeVito's HVAC paid the fee for the construction permit for the property located at 1478 Bradley Avenue on December 11, 2023; and

WHEREAS, DeVito's HVAC was overcharged on the permit, and it is necessary to refund the overpayment in the amount of \$860.00; and

WHEREAS, the Director of Code Enforcement has requested that City Council authorize the issuance of a refund to DeVito's HVAC in the amount of \$860.00 for the overcharged construction permit; now, therefore

BE IT RESOLVED, by the City Council of the City of Camden that the Director of Finance is hereby authorized to issue a refund in the amount of \$860.00 as follows:

Refund to: DeVito's HVAC
 592 Sherrington lane,
 Runnemede, NJ 08078

Refund Amount: \$860.00

BE IT FURTHER RESOLVED, that pursuant to N.J.S.A. 52:27BBB-23, a true copy of this Resolution shall be forwarded to the State Commissioner of Community Affairs, who shall have ten (10) days from the receipt thereof to veto this Resolution. All notices of veto shall be filed in the Office of the Municipal Clerk.

Date: March 12, 2024

The above has been reviewed
and approved as to form.



DANIEL S. BLACKBURN
City Attorney

ANGEL FUENTES
President, City Council

ATTEST: _____
LUIS PASTORIZA
Municipal Clerk



CITY OF CAMDEN — CITY COUNCIL ACTION REQUEST FORM

COUNCIL MEETING DATE: MARCH 12, 2024

TO: City Council
FROM: Gabriel Camacho, Director of Code Enforcement

TITLE OF ORDINANCE/RESOLUTION: "Resolution Authorizing the Reimbursement Of A Construction Permit, to DeVito's HVAC, In The Amount \$860.00."

Point of Contact:	Gabriel Camacho	Code Enforcement	856-757-7345	GaCamacho@ci.camden.nj.us
	Name	Department-Division- Bureau	Phone	Email

ENDORSEMENTS

	Recommend Approval (Y/N)	Signature	Date	Comments
Responsible				
Department Director				
Supporting Department Director (if necessary)				
Director of Grants Management				
Qualified Purchasing Agent				
Director of Finance				

Approved by: _____

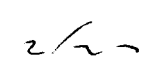
Business Administrator		
	Signature	Date

Attachments (list and attach all available):

1. Waiver Request Form Attached for State DCA/DLGS Approval - (If applicable)¹
2. Certification of Funds²
3. Addition supporting documents.

"Walk-on" note: All walk-on legislation must be pre-approved by the Business Administrator. The Department Director and Contact Person are jointly responsible for delivering all necessary documents to the City Clerk for distribution at the Council Meeting.

Received by: _____

City Attorney		FEB 29 2024
	Signature	Date

¹ For Example: Form "A" - Request for approval of Employees Requiring Advice and Consent of Governing Body, Form "D" - Contract Request, Form "E" - Creation/Extension of Services, Form "G" - Grant Approval, Form "H" - Bond Ordinance or Contract Request, Form "I", "Best Price Insurance Contracting" Model Ordinance

² Mandatory for any financial commitment to the City or expenditure of City Funds.

EXECUTIVE SUMMARY

TITLE OF ORDINANCE/RESOLUTION: Reimbursement

FACTS/BACKGROUND: (Executive level details. Short concise bullets)

- DeVito's HVAC, 592 Sherrington Lane, Runnemede, NJ 08078 (Contractor)
- Purchased a Construction Permit
- Was overcharged for the cost of the Permit, seeking reimbursement

AMOUNT OF PROPOSED CONTRACT or TOTAL COST OF PROPOSAL: \$860.00

IMPACT STATEMENT:

DeVito's HVAC purchased a construction permit from the City of Camden, Building Bureau. Customer was overcharged for the cost of the permit and therefore, he is requesting reimbursement of the overpayment.

SUBJECT MATTER EXPERTS/ADVOCATES:

- James Rizzo, Construction Official
 - Attendance: (Y/N/Tentative). Confirmed?

COORDINATION:

- Department of Code Enforcement

Prepared by: Mrs. Terry Britt

TeBritt@ci.camden.nj.us

Name

Phone/Email

**DeVito's HVAC
COOLING & HEATING
SALES, SERVICE
& INSTALLATION**

2-2-24

Affordable, Dependable, Reputable
856-939-4609
Master HVAC Contractor
19HC00779500 Lic #13VH0003680



James Rizzo,

The City of
Camden made a mistake on the cost
of mechanical for a boiler change
out as shown on permit number
24-CP-0136 could the City of
Camden correct this problem
so Kimberly Arist could get
a refund on cost of permit
that she paid.

RECEIVED
FEB 05 2024
BY: _____

Thank's
Michael DeVito



CITY OF CAMDEN
520 MARKET STREET
CITY HALL, ROOM 403
CAMDEN, NJ 08101
(856)757-7032

Page 1 of 1

INVOICE

Reference: 2023-3568

Invoice Date: 2/6/2024

Name: KIMBERLY ARTIS Block/Lot: 1281 7
Address: 1478 BRADLEY AVENUE
CAMDEN NJ 08103 Site Address: 1478 BRADLEY AVE
CAMDEN, NJ

The charges below for the application referenced are due. Failure to pay for and obtain Permit/Update/CCO prior to performing work may result in a Violation and/or Penalty.

Charge	Description	Date	Amount of Charge	Payments or Adjustments	Balance Due
Mechanical Permit Fee		12/11/2023	- 860.00	0.00	- 860.00

Total Amount Due: \$860.00-

You may send in a check or money order made out to the CITY OF CAMDEN to the address below. Please include the reference number: Application2023-3568 on your payment. Please do not send cash through the mail, cash payments must be made in person.

REMIT PAYMENT TO: CITY OF CAMDEN
520 MARKET STREET
CITY HALL, ROOM 403
CAMDEN, NJ 08101

CODE: 0EG



CITY OF CAMDEN
520 MARKET STREET
CAMDEN, NJ 08101
 Phone: (856)757-7032
 Fax: (856) 757-7259

Permit Number: 24-CP-0136
 Update Number:
 Control Number: 2023-3568
 Application Date: 12/12/2023
 Permit Date: 2/1/2024

CONSTRUCTION PERMIT

IDENTIFICATION

OWNER/ PROPERTY DETAILS

Block: 1281 Lot: 7 Qualifier:

Work Site Location **1478 BRADLEY AVE**
CAMDEN NJ

Owner in Fee **KIMBERLY ARTIS**
 Telephone

Address **1478 BRADLEY AVENUE**
CAMDEN NJ 08103

Use Group(s): **R-5**

Contractor **DEVITOS HVAC**
 Telephone **(856)939-4609**
 Address **592 SHERRINGTON LANE**
RUNNEMEDE NJ 08078

Lic. No. / Bldrs. Reg. No **19HC00779500**
 Federal Emp. No. **223338099**

is hereby granted permission to perform the following work:

- Building Electrical Plumbing
 Mechanical

DESCRIPTION OF WORK:
**TANK REMOVAL, GAS PIPING, HOT WATER BOILER,
 BACKFLOW PREVENTER, SWITCH**

ESTIMATED COST OF WORK:

Cost of Construction: **\$0.00**
 Cost of Alteration: **\$9,800.00**
 Cost of Demolition: **\$0.00**

Total Cost: \$9,800.00

If construction does not commence within one year of date of issuance,
 or if construction ceases for a period of six months, this permit is void

 _____ Date: **2/1/2024**
 James Rizzo
 Construction Official

- :: Failure to obtain all required inspections may result in administrative action
- :: Final inspections are required before final payment is to be made to contractor
- :: An approved set of plans must be kept at the worksite at all times

Notes:

PAYMENTS (Office Use Only)

Building	\$61.00
Electrical	\$61.00
Plumbing	\$61.00
Fire Protection	
Elevator Devices	
Mechanical	\$1,032.00
VolFee (DCA)	
AltFee (DCA)	\$19.00
DCA Minimum Fee	
Other Fees	
CO Fee	
CCO Fee	
Minimum Fee	
Total	\$1,234.00
No Fees Waived	

Amount to be Paid: \$0.00

Check Amount: **\$1,234.00**
 Payment Date: **2/1/2024**
 Collected By: **Shana Mosby**
 Reference No: **131**

Total Check Amount **\$1,234.00**

Grand Total: \$1,234.00



CITY OF CAMDEN
ELECTRICAL SUBCODE
TECHNICAL SECTION #1



Block 1281 Lot 7 Qualification Code
Work Site Location 1478 BRADLEY AVE
Owner In Fee KIMBERLY ARTIS
Telephone 1478 BRADLEY AVENUE, CAMDEN NJ 08103
Address DEVITOS HVAC
Telephone (856)939-4609 e-mail devitoshvac@gmail.com
Address 592 SHERRINGTON LANE, RUNNEMEDE NJ 08078
Contractor License No. Exp. Date

Date Received 12/12/2023 Date Issued 2/1/2024
Control # 2023-3568 Permit # 24-CP-0136
QTY. 1 SIZE ITEMS
Lighting Fixtures
Receptacles
Switches
Detectors
Light Poles
Motor - Fract. HP
Emergency & Exit Lights
Communication Points
Alarm Devices/ F.A.C. Panel
Microinverters
Other 1:
Other 2:
TOTAL NUMBERS
Pool Permit/ with UV Lights
Storable Pool/ Spa/ Hot Tub
KW Elec. Ranges/ Receptacle
KW Over/ Surface Unit
KW Elec. Water Heater
KW Elec. Dryer/ Receptacle
KW Dishwasher
HP Garbage Disposal
KW Central A/C Unit
HP/ KW Space Htr/ Air
KW Baseboard Heat
HP Motors 1/ +HP
KW Transformer/ Generator
AMP Service
AMP Subpanels
AMP Motor Control Center
KW Elec. Sign/ Outlet Light
KW Photovoltaic Systems
Other 3:
Other 4:
Other 5:
Other 6:
Other 7:
Other 8:
Other 9:
TOTAL FEE \$ 61.00

A. IDENTIFICATION - APPLICANT: COMPLETE ALL APPLICABLE INFORMATION, WHEN CHANGING CONTRACTORS, NOTIFY THIS OFFICE. CALL UTILITY DIG NO: 1-800-272-1000.
B. ELECTRICAL CHARACTERISTICS
Use Group Present R-5 Proposed
Building Occupied as
1. New/ Addition:
3. Demolition:
Federal Emp. ID No. 223338099
Home Improvement Contractor Registration No. or Exemption Reason
Contractor License No. Exp. Date
Telephone (856)939-4609 e-mail devitoshvac@gmail.com
Address 592 SHERRINGTON LANE, RUNNEMEDE NJ 08078
Contractor License No. Exp. Date
Home Improvement Contractor Registration No. or Exemption Reason
Federal Emp. ID No. 223338099
Use Group Present R-5 Proposed
Building Occupied as
1. New/ Addition:
3. Demolition:

JOB SUMMARY (Office Use Only)

PLAN REVIEW:
 No Plans Required
 Partial Under/ab. Utilities Approved
 Electric Plans Approved
 Joint Plan Review Required
 Blgd. Plumb. Fire Elevator
 Subcode Approval for PERMIT
 Subcode Approval for CERTIFICATE
 CO CCO CA
 Date Approved by: _____

INSPECTIONS (Dates: Month/Day)

Type	Failure	Approval	Initial
Rough			
Barrier Free			
Trench			
Temp. Serv.			
Const. Serv.			
TCO			
Other:			
Service			
Final			
Barrier Free			
Temp. Cut-in Card Date Issued			
Final Cut-In Card Date Issued			
Annual Pool Inspection			
Date of Grounding and Bonding			

C. CERTIFICATION IN LIEU OF OATH
I hereby certify that I am the (agent of) owner of record and am authorized to make this application.

D. TECHNICAL SITE DATA
DESCRIPTION OF WORK
TANK REMOVAL, GAS PIPING, HOT WATER BOILER, BACKFLOW PREVENTER, SWITCH

Sign here: _____
Print name: _____
here: _____
[] Electrical Contractor [] Exempt Applicant
[] Landscaping Irrigation Contractor

U.O.C. F120 (rev. 11/09) Applies
In submitting this form to your Local Construction Code Enforcement Office, please provide one original plus _____ copies

Administrative Surcharge
Minimum Fee
State Permit Surcharge Fee
TOTAL FEE \$ 61.00



CITY OF CAMDEN

PLUMBING SUBCODE
TECHNICAL SECTION #1



A. IDENTIFICATION - APPLICANT: COMPLETE ALL APPLICABLE INFORMATION, WHEN CHANGING CONTRACTORS, NOTIFY THIS OFFICE. CALL UTILITY DIG NO: 1-800-272-1000.

Block 1281 Lot 7 Qualification Code

Work Site Location 1478 BRADLEY AVE

Owner In Fee KIMBERLY ARTIS

Telephone e-mail kimmiley07@gmail.com

Address 1478 BRADLEY AVENUE, CAMDEN NJ 08103

Contractor WAYNE R STOVER

Telephone e-mail monsterplumber1@gmail.com

Address 456 COLONIAL ROAD, BELLMAWR NEW JERSEY 08031

Contractor License No. Exp. Date

Home Improvement Contractor Registration No. or Exemption Reason

Federal Emp. ID No. 222695073 Fax

B. PLUMBING CHARACTERISTICS

Use Group Present R-5 Proposed

Building Sewer Size

Water Service Size

1. New/ Addition:

3. Demolition:

Public Sewer

Public Water

2. Rehabilitation: \$ 300.00

Est. Cost of Plumbing Work (1+2+3): \$ 300.00

Private Septic

Private Well

Est. Cost of Plumbing Work (1+2+3): \$ 300.00

D. TECHNICAL SITE DATA

Date Received 12/12/2023 Date Issued 2/1/2024
Control # 2023-3568 Permit # 24-CP-0136

DESCRIPTION OF WORK
TANK REMOVAL, GAS PIPING, HOT WATER BOILER, BACKFLOW
PREVENTER, SWITCH

QTY.

FIGURE/EQUIPMENT:

- Water Closet
- Urinal/ Bidet
- Bath Tub
- Lavatory
- Shower
- Floor Drain
- Sink
- Dishwasher
- Drinking Fountain
- Washing Machine
- Hose Bibb
- Water Heater
- Fuel Oil Piping
- Gas Piping
- LP Gas Tank
- Steam Boiler
- Hot Water Boiler
- Sewer Pump
- Interceptor/ Separator
- Backflow Preventer (R)
- Backflow Preventer (C)
- Greasetrap
- Air Conditioning
- Sewer Connection
- Water Service Connection
- Stacks
- Other 1:
- Other 2:
- Other 3:
- Other 4:
- Other 5:
- Other 6:

JOB SUMMARY (Office Use Only)

PLAN REVIEW: No. Plans Required Partial Underlab. Utilities Approved

Date: _____ Approved by: _____

Plumbing Plans Approved Date: _____ Approved by: _____

Joint Plan Review Required: Bldg. Elec. Fire Elevator

SUBCODE APPROVAL FOR PERMIT Date: _____ Approved by: _____

SUBCODE APPROVAL FOR CERTIFICATE Date: _____ Approved by: _____

CO COO CA CA

INSPECTIONS

Type	Failure	Approval	Initial	Dates (Month/Day)
Slab				
Rough				
Water				
Sewer				
Fixtures				
Gas Equipment				
Gas Piping				
LP Gas Tank				
Fuel Oil Piping				
Solar				
TCO				
Final				

C. CERTIFICATION IN LIEU OF OATH

I hereby certify that I am the (agent of) owner of record and am authorized to make this application.

Sign here: _____
Print name _____
[] Licensed Plumbing Contractor [] Exempt Applicant

FEES (Office Use Only)

Administrative Surcharge
Minimum Fee
State Permit Surcharge Fee
TOTAL FEE

Administrative Surcharge	\$ 1.00
Minimum Fee	\$ 1.00
State Permit Surcharge Fee	\$ 1.00
TOTAL FEE	\$ 3.00



CITY OF CAMDEN
520 MARKET STREET
CAMDEN, NJ 08101
Phone: (856)757-7032
Fax: (856) 757-7259
E-mail:

February 1, 2024

KIMBERLY ARTIS
1478 BRADLEY AVE
CAMDEN, NJ

Block/Lot/Qual: 1281 7

The CITY OF CAMDEN hereby issues a RECEIPT to KIMBERLEY C ARTIS regarding: Construction Permit.

Fees Due:

State Permit Surcharge (Bldg)	1.00
Building Permit Fee	61.00
State Permit Surcharge (Plumbing)	1.00
Plumbing Permit Fee	61.00
Electric Permit Fee	61.00
State Permit Surcharge (Mechanical)	17.00
Mechanical Permit Fee	1,032.00

Total Fees:

1,234.00

Adjustments:

Amount of Payment Applied:

\$1,234.00

Balance Due:

Payment Information: Payment - Permit

Remit Type:	Check	Payment Amount:	\$1,234.00
Receipt ID:	2024-EN-000292	Reference Date:	2/1/2024
Reference:	131		
Recorded By:	Shana Mosby	Recorded Date:	2/1/2024

Reference ID: 2023-3568



CITY OF CAMDEN
 520 MARKET STREET
 CITY HALL, ROOM 403
 CAMDEN, NJ 08101

INVOICE

Reference: 2023-3568

Invoice Date: 1/9/2024

Name: KIMBERLY ARTIS Block/Lot: 1281 7
 Address: 1478 BRADLEY AVENUE
 CAMDEN NJ 08103 Site Address: 1478 BRADLEY AVE
 CAMDEN, NJ

The charges below for the application referenced are due. Failure to pay for and obtain Permit/Update/CCO prior to performing work may result in a Violation and/or Penalty.

Charge	Description	Date	Amount of Charge	Payments or Adjustments	Balance Due
State Permit Surcharge (Bldg)		12/12/2023	1.00	0.00	1.00
Building Permit Fee		12/12/2023	61.00	0.00	61.00
State Permit Surcharge (Plumbing)		12/12/2023	1.00	0.00	1.00
Plumbing Permit Fee		12/12/2023	61.00	0.00	61.00
Electric Permit Fee		12/12/2023	61.00	0.00	61.00
State Permit Surcharge (Mechanical)		12/12/2023	17.00	0.00	17.00
Mechanical Permit Fee		12/12/2023	1,032.00	0.00	1,032.00

Total Amount Due: \$1,234.00

You may send in a check or money order made out to the CITY OF CAMDEN to the address below. Please include the reference number: Application2023-3568 on your payment. Please do not send cash through the mail, cash payments must be made in person.

REMIT PAYMENT TO: CITY OF CAMDEN
 520 MARKET STREET
 CITY HALL, ROOM 403
 CAMDEN, NJ 08101

CITY OF CAMDEN
 PAID
 FEB 01 2024
 CASHIER #7

CODE: EG



CITY OF CAMDEN
MECHANICAL SUBCODE
TECHNICAL SECTION #1



Date Received 12/12/2023 Date Issued 2/1/2024
 Control # 2023-3568 Permit # 24-CP-0136

A. IDENTIFICATION - APPLICANT: COMPLETE ALL APPLICABLE INFORMATION. WHEN CHANGING CONTRACTORS, NOTIFY THIS OFFICE. CALL UTILITY DIG NO: 1-800-272-1000.

Block 1281 Lot 7 Qualification Code

Work Site Location 1478 BRADLEY AVE

Owner In Fee KIMBERLY ARTIS

Telephone e-mail kimmiley07@gmail.com

Address 1478 BRADLEY AVENUE, CAMDEN NJ 08103

Contractor DEVITOS HVAC

Telephone (856)939-4609 e-mail devitoshvac@gmail.com

Address 592 SHERRINGTON LANE, RUNNEMEDE NJ 08078

Contractor License No. or Builder Registration Number 19HC00779500 Exp. Date 6/30/2020

Home Improvement Contractor Registration No. or Exemption Reason

Federal Emp. ID No. 223338099 Fax

B. MECHANICAL CHARACTERISTICS

Use Group: R-5 Heating System work: New or Modification to Existing or Conversion or Replacement

Type: Hydronic Hot Air
 Fuel Type: Gas Oil Electric Solar Other:

- 1. New Building Estimated Cost of Elevator Work (1+2+3): \$ 8,800.00
- 2. Rehabilitation \$ 8,800.00
- 3. Demolition

JOB SUMMARY (Office Use Only)

PLAN REVIEW

No Plans Required.

Mechanical Plans Approved

Date: Approved by:

Elevator Layout Drawings

Date: Approved by:

Joint Plan Review Required:

Bldg: Elec: Plumb: Fire

Elev:

SUBCODE APPROVAL FOR PERMIT

Date: Approved by:

SUBCODE APPROVAL FOR CERTIFICATE

Date: CA CCO

Approved by:

INSPECTIONS

Type: Gas Piping

Appliance

Chimney/Vent

Oil Piping

Oil Tank

LPG Tank

Hydronic Piping

Fireplace

Chimney Cert.

Other:

Dates (Month/Day)

Failure Approval Initial

C. CERTIFICATION IN LIEU OF OATH
 I hereby certify that I am the (agent of) owner of record and am authorized to make this application.

Sign here:

Print name here:

D. TECHNICAL SITE DATA

DESCRIPTION OF WORK

TANK REMOVAL, GAS PIPING, HOT WATER BOILER, BACKFLOW PREVENTER, SWITCH

NO. FEATURE/EQUIPMENT

- 1 Water Heater
- 1 Fuel Oil Piping \$ 86.00
- 1 Gas Piping
- 1 Steam Boiler
- 11 Hot Water Boiler \$ 946.00
- Hot Air Furnace
- Oil Tank
- LPG Tank
- Fireplace
- Generator
- Other 1:
- Other 2:
- Other 3:
- Other 4:

Administrative Surcharge
 Minimum Fee \$ 17.00
 State Permit Surcharge Fee
TOTAL FEE \$ 1,049.00

Fee (Office Use Only)
 \$ 1,049.00



CITY OF
520 MAF
CAMDEN
Phone: (856) 962-2000
Fax: (856) 962-2000

CORRECTION

Permit Number: 24-CP-0136
Update Number:
Control Number: 2023-3568
Application Date: 12/12/2023
Permit Date: 2/1/2024

CONSTRUCTION PERMIT

IDENTIFICATION

OWNER/ PROPERTY DETAILS

Block: 1281 Lot: 7 Qualifier:

Work Site Location **1478 BRADLEY AVE**
CAMDEN NJ
Owner in Fee **KIMBERLY ARTIS**
Telephone
Address **1478 BRADLEY AVENUE**
CAMDEN NJ 08103

Contractor **DEVITOS HVAC**
Telephone **(856)939-4609**
Address **592 SHERRINGTON LANE**
RUNNEMEDE NJ 08078

Use Group(s): **R-5**

Lic. No. / Bldrs. Reg. No **19HC00779500**
Federal Emp. No. **223338099**

is hereby granted permission to perform the following work:

Building Electrical Plumbing
 Mechanical

DESCRIPTION OF WORK:
**TANK REMOVAL, GAS PIPING, HOT WATER BOILER,
BACKFLOW PREVENTER, SWITCH**

ESTIMATED COST OF WORK:

Cost of Construction: **\$0.00**
Cost of Alteration: **\$9,800.00**
Cost of Demolition: **\$0.00**

Total Cost: \$9,800.00

If construction does not commence within one year of date of issuance, or if construction ceases for a period of six months, this permit is void

JAMES RIZZO

CONSTRUCTION OFFICIAL

Date: **2/7/2024**

James Rizzo
Construction Official

- :: Failure to obtain all required inspections may result in administrative action
- :: Final inspections are required before final payment is to be made to contractor
- :: An approved set of plans must be kept at the worksite at all times

Notes:

PAYMENTS (Office Use Only)

Building	\$61.00
Electrical	\$61.00
Plumbing	\$61.00
Fire Protection	
Elevator Devices	
Mechanical	\$1,032.00
VolFee (DCA)	
AltFee (DCA)	\$19.00
DCA Minimum Fee	
Other Fees	
CO Fee	
CCO Fee	
Minimum Fee	
Total	\$374.00
No Fees Waived	

Amount to be Paid: (\$860.00)

Check Amount: **\$1,234.00**
Payment Date: **2/1/2024**
Collected By: **Shana Mosby**
Reference No: **131**

Total Check Amount \$1,234.00

Grand Total: \$1,234.00



CITY OF CAMDEN

**PLUMBING SUBCODE
TECHNICAL SECTION #1**

CORRECTION

Issued 12/12/2023
2023-3568

Date Issued 2/1/2024
Permit # 24-CP-0136

A. IDENTIFICATION - APPLICANT: COMPLETE ALL APPLICABLE INFORMATION. WHEN CHANGING CONTRACTORS, NOTIFY THIS OFFICE. CALL UTILITY DIG NO: 1-800-272-1000.

Block **1281** Lot **7** Qualification Code

Work Site Location **1478 BRADLEY AVE**

Owner in Fee **KIMBERLY ARTIS**

Telephone e-mail **kimmitley07@gmail.com**

Address **1478 BRADLEY AVENUE, CAMDEN NJ 08103**

Contractor **WAYNE R STOVER**

Telephone e-mail **monsterplumber1@gmail.com**

Address **456 COLONIAL ROAD, BELLMAWR NEW JERSEY 08031**

Contractor License No. Exp. Date

Home Improvement Contractor Registration No. or Exemption Reason

Federal Emp. ID No. **222695073** Fax

B. PLUMBING CHARACTERISTICS

Use Group Present **R-5 Proposed**

Building Sewer Size

Water Service Size

1. New/ Addition:

2. Rehabilitation: **\$ 300.00**

3. Demolition: Est. Cost of Plumbing Work (1+2+3): **\$ 300.00**

INSPECTIONS

Dates (Month/Day)

PLAN REVIEW	Type:	Failure	Failure	Approval	Initial
<input checked="" type="checkbox"/> No Plans Required	Slab	_____	_____	_____	_____
<input type="checkbox"/> Partial - Under/Slab Utilities Approved	Rough	_____	_____	_____	_____
Date: _____ Approved by: _____	Water	_____	_____	_____	_____
<input type="checkbox"/> Plumbing Plans Approved	Sewer	_____	_____	_____	_____
Date: _____ Approved by: _____	Fixtures	_____	_____	_____	_____
Joint Plan Review Required:	Gas Equipment	_____	_____	_____	_____
<input type="checkbox"/> Bldg. <input type="checkbox"/> Elec. <input type="checkbox"/> Fire <input type="checkbox"/> Elevator	Gas Piping	_____	_____	_____	_____
SUBCODE APPROVAL for PERMIT	LP Gas Tank	_____	_____	_____	_____
Date: _____ Approved by: _____	Fuel Oil Piping	_____	_____	_____	_____
SUBCODE APPROVAL for CERTIFICATE	Solar	_____	_____	_____	_____
<input type="checkbox"/> CO <input type="checkbox"/> CCO <input type="checkbox"/> CA	TCO	_____	_____	_____	_____
Date: _____ Approved by: _____	Final	_____	_____	_____	_____

D. TECHNICAL SITE DATA

DESCRIPTION OF WORK
TANK REMOVAL, GAS PIPING, HOT WATER BOILER, BACKFLOW PREVENTER, SWITCH

QTY.

FIXTURE/ EQUIPMENT:

- Water Closet
- Urinal/ Bidet
- Bath Tub
- Lavatory
- Shower
- Floor Drain
- Sink
- Dishwasher
- Drinking Fountain
- Washing Machine
- Hose Bibb
- Water Heater
- Fuel Oil Piping
- Gas Piping
- LP Gas Tank
- Steam Boiler
- Hot Water Boiler
- Sewer Pump
- Interceptor/ Separator
- Backflow Preventer (R)
- Backflow Preventer (C)
- Greasetrap
- Air Conditioning
- Sewer Connection
- Water Service Connection
- Stacks
- Other 1:
- Other 2:
- Other 3:
- Other 4:
- Other 5:
- Other 6:

FEE (Office Use only)

\$ 13.00

C. CERTIFICATION IN LIEU OF OATH

I hereby certify that I am the (agent of) owner of record and am authorized to make this application.

Sign here: _____

Print name _____

[] Licensed Plumbing Contractor [] Exempt Applicant

Administrative Surcharge

Minimum Fee **\$ 1.00**

State Permit Surcharge Fee

TOTAL FEE **\$ 62.00**

R-32

SE:dh
03-12-24

RESOLUTION AUTHORIZING PENNSAUKEN ANIMAL HOSPITAL TO PROVIDE AS NEEDED VETERINARY SERVICES FOR THE CARE OF WOUNDED STRAY ANIMALS IMPOUNDED THROUGHOUT THE CITY OF CAMDEN DURING NORMAL BUSINESS HOURS

WHEREAS, the City of Camden has a need for veterinary services to care for wounded stray animals before they are impounded at a designated shelter; and

WHEREAS, the anticipated term of this contract is one (1) year; and

WHEREAS, the Local Public Contracts Law, N.J.S.A. 40A:11-5(1)(a), permits the awarding of a contract, without competitive bidding for "Professional Services"; and

WHEREAS, **PENNSAUKEN ANIMAL HOSPITAL** will provide veterinary services to care for wounded stray animals, found during normal business hours, before the animals are impounded at a designated shelter for a one (1) year time period in accordance with the other terms and conditions of the Agreement for the amount not to exceed FIFTY THOUSAND DOLLARS (\$50,000.00); and

WHEREAS, pursuant to the directive of the Division of Local Government Services, a certification has been attached hereto which certifies that the funds for this expenditure are available and appropriated for in the budget of the City of Camden under line item "4-01-E4-601-908", and said certification has been signed by the Chief Financial Officer and approved as to form by the City Attorney; now, therefore

BE IT RESOLVED, by the City Council of the City of Camden, that the proper City Officers of the City of Camden are hereby authorized to execute a contract with **PENNSAUKEN ANIMAL HOSPITAL**, for an amount not to exceed FIFTY THOUSAND DOLLARS (\$50,000.00), to provide veterinary services to care for wounded stray animals, found during normal business hours, before they are impounded at designated shelter, in accordance with the other terms and conditions of the Agreement, according to Public Contracts Law, P.L. 1971, Chapter 198, and that the Mayor and the City Clerk shall execute said contract on behalf of the City of Camden.

BE IT FURTHER RESOLVED, that pursuant to N.J.S.A. 52:27BBB-23, a true copy of this Resolution shall be forwarded to the State Commissioner of Community Affairs, who shall have ten (10) days from the receipt thereof to veto this Resolution. All notices of veto shall be filed in the Office of the Municipal Clerk.

Date: March 12, 2024

The above has been reviewed and approved as to form.



DANIEL S. BLACKBURN
City Attorney

ANGEL FUENTES
President, City Council

ATTEST: _____
LUIS PASTORIZA
Municipal Clerk

CITY OF CAMDEN

CERTIFICATION AS TO THE AVAILABILITY OF FUNDS

I CERTIFY, DIRECTOR FOR THE FINANCE DEPARTMENT FOR THE CITY OF CAMDEN, THAT WITH RESPECT TO THE AWARD OF A CONTRACT OR EXPENDITURE OF FUNDS TO: PENNSUAKEN ANIMAL HOSPITAL

THAT THE FUNDS ARE AVAILABLE AS OF THE DATE OF THIS RESOLUTION/CERTIFICATION, FROM ONE OF THE FOLLOWING:

- BUDGET APPROPRIATION:4-01-E4-601-908
AMOUNT: \$ 50,000.00
- DEDICATED BY RIDER:
AMOUNT:\$
- TEMPORARY RESERVE FOR STATE AND FEDERAL GRANT:
AMOUNT:\$
- CAPITAL ORDINANCE
AMOUNT:\$
- TRUST ACCOUNT:
AMOUNT: \$

DETERMINATION OF VALUE CERTIFICATION

I CERTIFY, AS CHIEF FINANCIAL OFFICER, THAT THE ANTICIPATED VALUE OF THE CONTRACT, OVER THE FULL LIFE, WILL BE: \$ 50,000.00

DESCRIPTION OF THE GOODS AND SERVICES TO BE PROCURED: RESOLUTION AUTHORIZING PENNSUAKEN ANIMAL HOSPITAL TO PROVIDE AS NEEDED VETERINARY SERVICES FOR THE CASE OF WOUNDED STRAY ANIMALS IMPOUNDED THROUGHOUT THE CITY OF CAMDEN DURING NORMAL BUSINESS HOURS

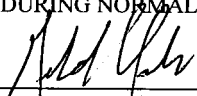

Gerald C. Seneski
Director of Finance
Date: 2/21



CITY OF CAMDEN — CITY COUNCIL ACTION REQUEST FORM



COUNCIL MEETING DATE: 03/12/2024

TO: City Council
FROM: Gabriel Camacho, Director of Code Enforcement 

TITLE OF ORDINANCE/RESOLUTION: RESOLUTION AUTHORIZING PENNSAUKEN ANIMAL HOSPITAL TO PROVIDE AS NEEDED VETERINARY SERVICES FOR THE CARE OF WOUNDED STRAY ANIMALS IMPOUNDED THROUGHOUT THE CITY OF CAMDEN DURING NORMAL BUSINESS HOURS

Point of Contact:	Lateefah Chandler	Admin-Purchasing	856-757-7475	lachandl@ci.camden.nj.us
	Name	Department-Division-Bureau	Phone	Email

ENDORSEMENTS

	Recommend Approval (Y/N)	Signature	Date	Comments
Responsible Department Director Supporting Department Director (if necessary) Director of Grants Management	Y		2-21-24	
Qualified Purchasing Agent	Y		3/21	
Director of Finance	Y			

Approved by:
Business Administrator

 _____
Signature Date

Attachments (list and attach all available):

1. Waiver Request Form Attached for State DCA/DLGS Approval - (If applicable)¹
2. Certification of Funds²
3. Addition supporting documents.

"Walk-on" note: All walk-on legislation must be pre-approved by the Business Administrator. The Department Director and Contact Person are jointly responsible for delivering all necessary documents to the City Clerk for distribution at the Council Meeting.

Received by:
City Attorney

 _____
Signature Date FEB 29 2024

¹ For Example: Form "A" - Request for approval of Employees Requiring Advice and Consent of Governing Body, Form "D" - Contract Request, Form "E" - Creation/Extension of Services, Form "G" - Grant Approval, Form "H" - Bond Ordinance or Contract Request, Form "I", "Best Price Insurance Contracting" Model Ordinance

² Mandatory for any financial commitment to the City or expenditure of City Funds.

CAMDEN CITY

520 MARKET STREET
 P O BOX 95120
 CAMDEN, NJ 08101-5120
 TEL (856)757-7000

REQUISITION	
NO.	R2400095

SHIP TO	ANIMAL CONTROL OFFICE CAMDEN CITY HALL, RM. 403 520 MARKET STREET CAMDEN, NEW JERSEY 08101
VENDOR	VENDOR #: PEN07 PENNSAUKEN ANIMAL HOSPITAL ATTN: CHRISTOPHER TORRE VMO 6717 CRESCENT BLVD RT 130 PENNSAUKEN, NJ 08110

ORDER DATE: 01/09/24
 DELIVERY DATE:
 STATE CONTRACT:
 F.O.B. TERMS:

*Feb/MAR Council for New
 \$ 45K*

QTY/UNIT	DESCRIPTION	ACCOUNT NO.	UNIT PRICE	TOTAL COST
1.00	VETERINARY SERVICES	4-01-E4-601-908	10,000.0000	10,000.00
	PAYMENT IS NEEDED FOR VETERINARY SERVICES FOR THE CARE OF WOUNDED STRAY ANIMALS FOUND IN THE CITY OF CAMDEN, DURING NORMAL BUSINESS HOURS.			
	FOR THE MONTHS OF JAN. FEB. MAR. 2024			
		<i>1/17/2024</i>	TOTAL	10,000.00

CITY OF CAMDEN
 PURCHASING BUREAU
 2024 JAN 10 AM 9:53

Approved: 

 Department Head _____ Date _____

I hereby certify that the work or supplies specified are necessary for the proper transaction of the business of this bureau or office.

Mrs. Terry Britz 1-9-2024
 Receiver of Goods _____ Date _____

FORWARD THIS COPY OF THE REQUISITION TO THE PURCHASING BUREAU

EXECUTIVE SUMMARY

TITLE OF ORDINANCE/RESOLUTION: RESOLUTION AUTHORIZING PENNSAUKEN ANIMAL HOSPITAL TO PROVIDE AS NEEDED VETERINARY SERVICES FOR THE CARE OF WOUNDED STRAY ANIMALS IMPOUNDED THROUGHOUT THE CITY OF CAMDEN DURING NORMAL BUSINESS HOURS

FACTS/BACKGROUND: (Executive level details. Short concise bullets)

- Per NJSA 4:19-15.16 requires any impounded animal to be euthanized or offered for adoption
- City provides a designated shelter for this service. Per the agreement with the shelter, any obvious sick or injured animal requires emergency medical care before being impounded at the shelter.
- Value of contract determined by the amount spent in the last 12 months.
-

AMOUNT OF PROPOSED CONTRACT or TOTAL COST OF PROPOSAL: \$50,000.00

APPROPRIATION NUMBER: 4-01-E4-601-908

PROCUREMENT: N.J.S.A. 40A:11-5(1)(a)

IMPACT STATEMENT:

- Without this service, the City's animal control office cannot impound sick or injured animals due to the veterinary service requirement imposed by the shelter. The City utilizes several veterinary services due to the distance and time, Pennsauken is the main animal hospital. Red Bank, Northstar, Blackwood are hospitals utilized after hours or if Pennsauken is unavailable.

SUBJECT MATTER EXPERTS/ADVOCATES:

- Gabriel Camacho, Director of Code Enforcement

COORDINATION:

- N/A

Prepared by: LATEEAH CHANDLER

856-757-7475

Name

Phone/Email

**STATE OF NEW JERSEY
DEPARTMENT OF COMMUNITY AFFAIRS
DIVISION OF LOCAL GOVERNMENT SERVICES
CONTRACT REQUEST FORM**

This form must be filled out in its entirety and is intended to provide the Division with appropriate information to determine whether to approve a new or extended service. Please provide any additional information you believe will help the Division make an informed decision.

Municipality	CITY OF CAMDEN
--------------	----------------

Professional Service or EUS Type	N/A
Name of Vendor	PENNSAUKEN ANIMAL HOSPITAL
Purpose or Need for service:	VET SERVICES FOR WOUNDED STRAY ANIMALS FOR A PERIOD OF ONE (1) YEAR
Contract Award Amount	\$50,000.00
Term of Contract	12 MONTHS
Temporary or Seasonal	N/A
Grant Funded (attach appropriate documentation allowing for service through grant funds)	NO
Please explain the procurement process (i.e. bids, RFQ, competitive contracting, etc.)	N.J.S.A. 40A:11-5(1)(a)
Were other proposals received? If so, please attach the names and amounts for each proposal received?	N/A

Please attach the RFP, evaluation memoranda or evaluation forms used to evaluate the vendors and a list of all bidders and the bid amounts associated with each bidder.

If the lowest bidder was not selected, please have the appropriate personnel sign the certification on page 2.

Mayor's Signature* Date _____

Business Administrator/Manager Signature Date _____

*For direct appointments of the Governing Body, Council President or at the discretion of the Director, the most senior member of the Governing Body may sign the waiver in lieu of the Mayor.

The Financial Officer affirms that there is adequate funding available for this action.

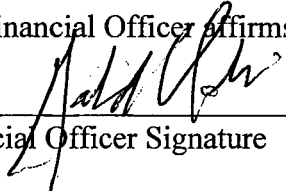

Financial Officer Signature

I certify that the vendor selected is in compliance with the adopted Pay to Play Ordinance and that the vendor was notified of any restrictions with respect to campaign contributions.

Pending _____ Date _____
Certifying Officer

For LGS use only:

 Approved Denied

Date _____
Director or Designee,
Division of Local Government Services

Number Assigned _____

Fee Schedule



pennsauken
animal hospital

6714 Wayne Ave
Pennsauken, NJ 08110
856-662-4450

www.facebook.com/PennsaukenVet

PAH Camden City (# PAHCC2022)
DO NOT USE ACCOUNT
Camden, NJ 08101

Feb 21, 2023
Invoice Number

OPEN
0

Financial

Date	Description	Emp.	Qty	Price
02/21/2023	Examination- Animal Control	PAH	1	\$ 76.00
	◆ Biohazard Disposal / PPE Fee, single use ²	PAH	1	\$ 10.25
	◆ Discount: Hospital Goodwill / Assistance	PAH	1	\$ (25.00)
	Rabies, Nobivac - 1 Year Protection	PAH	1	\$ 33.00
	ACO RAD- 1 View	PAH	1	\$ 75.00
	SNAP- Feiv / FIV	PAH	1	\$ 58.75
	SNAP- Parvovirus, Fecal Antigen	PAH	1	\$ 61.25
	Chem- Basic + CBC	PAH	1	\$ 107.40
	Catalyst Chem 10	PAH	1	\$ 0.00
	CBC: Complete Blood Cell Count	PAH	1	\$ 0.00
	Euthanasia, Cath+Meds < 30 lbs ¹	PAH	1	\$ 75.00
	• CUBEX Controlled Drug Dispensing Fee	PAH	1	\$ 4.73
	Euthanasia, Cath+Meds 30.1 - 79.9 lbs ¹	PAH	1	\$ 90.50
	• CUBEX Controlled Drug Dispensing Fee	PAH	1	\$ 4.73
	IV Catheter Placement ³	PAH	1	\$ 0.00
	Euthanasia, Cath+Meds > 80 lbs ¹	PAH	1	\$ 106.50
	• CUBEX Controlled Drug Dispensing Fee	PAH	1	\$ 4.73
	IV Catheter Placement ³	PAH	1	\$ 0.00

Total for Financial: \$ 682.84

Pennsauken Animal Hospital (PAH) - PAH

Total Invoice: \$ 682.84

¹Euthanasia - Condolences:

** Please accept our sincere condolences on the loss of your loved pet. Those of us who work in veterinary medicine can truly appreciate the loss and sorrow that is felt when we lose a beloved friend. If needed, our staff can provide contact information for a bereavement group.

²The ongoing pandemic has resulted in increased costs associated with obtaining Personal Protective Equipment (PPE) and with the disposal of medical waste, therefore, an additional fee has been charged in conjunction with your pet's visit.

³

Did you know you can request appointments, medication refills and pay your invoice right on our website?

R-33

DB:HM
03-12-24

RESOLUTION TO EXTEND THE TIME TO UTILIZE FUNDS IN THE AMOUNT OF \$4500.00 RECEIVED FROM THE CAMDEN COUNTY CULTURAL AND HERITAGE COMMISSION FOR THE COMPLETION OF THE HISTORIC MURAL/WEBSITE SPANISH TRANSLATIONS

WHEREAS, MC-23:8989, approved on June 13, 2023, permitted the City of Camden to accept a grant from the Camden County Cultural and Heritage Commission, through the New Jersey Historical Commission History Partnership Program, in the amount of \$4500.00 for the completion of the Historic Mural/Website Spanish Translations; and

WHEREAS, the grant agreement required that these funds be utilized and expended by on or before December 31, 2023; and

WHEREAS, the City of Camden and the Camden County Cultural and Heritage Commission have now agreed to extend the expiration date of the grant agreement by which these funds must be utilized and expended to no later than December 31, 2025; now, therefore

BE IT RESOLVED, by the City Council of the City of Camden that the City of Camden is hereby authorized to extend the expiration date of the grant agreement between the City of Camden and the Camden County Cultural and Heritage Commission by which these funds must be utilized and expended to no later than December 31, 2025.

BE IT FURTHER RESOLVED, that the appropriate officers of the City of Camden are hereby authorized to execute the necessary documents needed to extend the expiration date of the grant agreement between the City of Camden and the Camden County Cultural and Heritage Commission to no later than December 31, 2025.

BE IT FURTHER RESOLVED, that pursuant to N.J.S.A. 52:27BBB-23, a true copy of this Resolution shall be forwarded to the State Commissioner of Community Affairs, who shall have ten (10) days from the receipt thereof to veto this Resolution. All notices of veto shall be filed in the Office of the Municipal Clerk.

Date: March 12, 2024

The above has been reviewed and approved as to form.



DANIEL S. BLACKBURN
City Attorney

ANGEL FUENTES
President, City Council

ATTEST:

LUIS PASTORIZA
Municipal Clerk



CITY OF CAMDEN — CITY COUNCIL ACTION REQUEST FORM

CITY OF CAMDEN
FINANCE DEPARTMENT

2024 FEB 21 AM 11:48

COUNCIL MEETING DATE: 03/12/2024

TO: City Council
FROM: Luis Pastoriza, Municipal Clerk & Registrar

TITLE OF ORDINANCE/RESOLUTION: Resolution extending the term of grant agreement with Camden County Cultural and Heritage Commission for historic mural Spanish translation integration work through calendar year 2025.

Point of Contact:	Patrice Bassett	Municipal Clerk	X7049	Pamccart@ci.camden.nj.us
	Name	Department-Division-Bureau	Phone	Email

ENDORSEMENTS

	Recommend Approval (Y/N)	Signature	Date	Comments
Responsible Department Director	y		2/15/2024	
Supporting Department Director (if necessary)	y		2/21/24	
Director of Grants Management			2/21	
Qualified Purchasing Agent				
Director of Finance				
Approved by: Business Administrator			2/22	

Attachments (list and attach all available):

1. Waiver Request Form Attached for State DCA/DLGS Approval - (If applicable)¹
2. Certification of Funds²
3. Addition supporting documents.

“Walk-on” note: All walk-on legislation must be pre-approved by the Business Administrator. The Department Director and Contact Person are jointly responsible for delivering all necessary documents to the City Clerk for distribution at the Council Meeting.

Received by: FEB 29 2024

City Attorney Signature Date

¹ For Example: Form “A” - Request for approval of Employees Requiring Advice and Consent of Governing Body, Form “D” - Contract Request, Form “E” - Creation/Extension of Services, Form “G” - Grant Approval, Form “H” - Bond Ordinance or Contract Request, Form “I”, “Best Price Insurance Contracting” Model Ordinance

² Mandatory for any financial commitment to the City or expenditure of City Funds.

EXECUTIVE SUMMARY

TITLE OF ORDINANCE/RESOLUTION: Resolution extending the term of grant agreement with Camden County Cultural and Heritage Commission for historic mural Spanish translation integration work through calendar year 2025.

FACTS/BACKGROUND: (Executive level details. Short concise bullets)

- The City of Camden sought financial support to integrate Spanish translations of all 133 history content popups on the heritage tourism interactive mural (located in the lobby of City Hall) and the mural on the City of Camden website
- This \$4500 grant awarded from Camden County Cultural and Heritage Commission was only partial funds required to complete the work so we were unable to begin until the remaining funds were secured
- All monies needed have now been awarded and Camden County Cultural and Heritage Commission has agreed to extend the term of the grant (originally should have been spent in calendar year 2023) to complete this aspect of the project

AMOUNT OF PROPOSED CONTRACT or TOTAL COST OF PROPOSAL: \$4,500

IMPACT STATEMENT:

- This resolution simply extends the term of a previously established grant agreement – this extension will allow us the time needed to complete the aspects of the project identified under this agreement.
- 75% of funds have already been dispersed to the City for this work. The remaining 25% will be provided on completion of this project.

SUBJECT MATTER EXPERTS/ADVOCATES:

- Patrice Bassett, City of Camden Office of Municipal Clerk
 - Attendance: No

COORDINATION:

- Our research about the importance of translating the kiosk information into Spanish is founded on the fact that nearly half the residents of the City of Camden are Spanish speakers.
- The 2020 US Census Quick Facts notes 50.5% of Camden residents are Hispanic or Latino and 42% speak Spanish at home. In Camden County 17.6% of residents are Hispanic or Latino and 12.6% of the county population speaks Spanish at home.
- Given these statistics, Spanish translations of the mural content and website would expand the audience for Camden County history organizations and historic sites open to the public and allow for further educational opportunities.

Prepared by:

 Patrice Bassett pamccart@ci.camden.nj.us x 7049
Name Phone/Email

STATE OF NEW JERSEY
DEPARTMENT OF COMMUNITY AFFAIRS
DIVISION OF LOCAL GOVERNMENT SERVICES
GRANT APPROVAL FORM

This form must be filled out in its entirety and is intended to provide the Division with appropriate information to determine whether to approve a new or extended service. Please provide any additional information you believe will help the Division make an informed decision.

PLEASE EXPLAIN THE JUSTIFICATION FOR THE GRANT. PLEASE FULLY EXPLAIN COST ASSOCIATED WITH THE AWARD OF THE GRANT AS WELL AS ANY MATCHING FUNDS OR EMPLOYMENT OBLIGATIONS AS A TERM OF THE GRANT. PLEASE EXPLAIN THE BENEFITS OF THE GRANT OF THE MUNICIPALITY AND THE RESIDENTS. ATTACH THE GRANT APPLICATION AND GRANT AWARD LETTER.

This resolution extends the term of grant agreement already in place through calendar year 2025.

This \$4500 grant award was only partial funding needed to complete Spanish translation integration work for our historic mural. 75% of these grant funds have already been provided to the City of Camden. The remaining 25% will be dispersed upon completion of this work aspect.

Grant funds were supposed to be utilized in 2023 – but because all funding was not secured at this time the work timeline was held up. We now have all funding required to complete this portion of the project. The granting agency has already agreed to provide this extension (see attached email confirmation).

This grant covers costs associated with the Spanish translations on the interactive touchscreen historic mural located in the lobby of City Hall and translations required for our online platform (City of Camden website) as well. A resolution to accept this grant was done on June 13, 2023 MC#8989 and the previously approved DCA waiver is attached.

Our research about the importance of translating the kiosk information into Spanish is founded on the fact that nearly half the residents of the City of Camden are Spanish speakers. The 2020 US Census Quick Facts notes 50.5% of Camden residents are Hispanic or Latino and 42% speak Spanish at home. In Camden County 17.6% of residents are Hispanic or Latino and 12.6% of the county population speaks Spanish at home.

Given these statistics, Spanish translations of the mural content and website would expand the audience for Camden County history organizations and historic sites open to the public and allow for further educational opportunities.

Information of key municipal employee or agent applying for grant and responsible for its use:

Name	Patrice Bassett
Title	Records Manager & Acting Deputy Registrar
Telephone Number	856-757-7049
Email	pamccart@ci.camden.nj.us

If the grant is received and fully expended, what will the continuing financial obligations of the municipality be with respect to staffing, insurance, liability, operations, and/or maintenance?

After the first 3 years of coverage for operating costs associated with placing this historic data on the City of Camden website – the City will be required to pay for server updates from the city’s website vendor (GovDesigns). This may cause an increase of monthly costs by \$100.00 a month

What will the source of funds be for the staffing, insurance, liability, operations, and /or maintenance?

Maintenance/updating will be performed by the vendor GovDesigns as they do for every other aspect of the City website. Any changes to the data displayed in this section will be addressed by Patrice Bassett, in conjunction with Information Technology and the Communications Department of the City of Camden.

Mayor’s Signature

Date _____

Business Administrator/Manager Signature

Date _____

Name, email and fax of contact person for this form:

For LGS use only:

Approved

Denied

Director or Designee,
Division of Local Government Services

Date _____

Number Assigned _____

Patrice Bassett

From: Bruno, David <DBruno@camdencc.edu>
Sent: Thursday, February 8, 2024 2:49 PM
To: Patrice Bassett
Cc: Nicholson, Karen; Tomkinson, Andrea
Subject: RE: [External Email] FW: PAST DUE - Final Report - 2023 Camden County Cultural & Heritage Commission - CHPP Regrant

Patrice – Thank you for the update, and I understand the situation. Yes, we can provide an extension to utilize the funding already dispersed to you, but the remaining 25% of the funding cannot be issued until the completion of the final report.

I hope this helps, and please keep me updated on the progress towards completion.

David Bruno

David Bruno

Associate Dean of Educational Programming and External Relations
Executive Director, Camden County Cultural & Heritage Commission
Camden County College
William G. Rohrer Center
1889 Route 70 East
Cherry Hill, NJ 08003
(856) 874-6000 or (856) 227-7200 x4494

From: Patrice Bassett <PaMcCart@ci.camden.nj.us>
Sent: Thursday, February 8, 2024 10:12 AM
To: Nicholson, Karen <knicholson@camdencc.edu>; Bruno, David <DBruno@camdencc.edu>
Subject: RE: [External Email] FW: PAST DUE - Final Report - 2023 Camden County Cultural & Heritage Commission - CHPP Regrant

Thank you Karen.

Mr. Bruno - Obviously, the importance of this aspect of the project remains and we hope this will be ok with the Cultural & Heritage Commission. If we could officially request an extension that would be great. As mentioned, we have now secured the remaining funds needed and I am getting through the City's contract requirements now. We hope to begin very soon. Please advise, thank you.

Patrice Bassett M.A., C.M.R.
Acting Deputy Registrar of Vital Statistics
Records Manager
Office of the Municipal Clerk
City of Camden
520 Market St. Camden, NJ 08101
Office: 856-757-7049

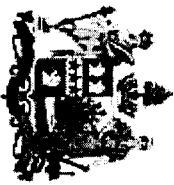

From: Nicholson, Karen <knicholson@camdencc.edu>
Sent: Thursday, February 8, 2024 9:55 AM
To: Patrice Bassett <PaMCCart@ci.camden.nj.us>
Cc: Bruno, David <DBruno@camdencc.edu>
Subject: RE: [External Email] FW: PAST DUE - Final Report - 2023 Camden County Cultural & Heritage Commission - CHPP Regrant

Hi Patrice,

I am copying David Bruno on this response. He is overseeing the Cultural and Heritage Commission now.

Karen

From: Patrice Bassett <PaMCCart@ci.camden.nj.us>
Sent: Thursday, February 8, 2024 9:44 AM
To: Nicholson, Karen <knicholson@camdencc.edu>
Subject: [External Email] FW: PAST DUE - Final Report - 2023 Camden County Cultural & Heritage Commission - CHPP Regrant

CAUTION: This email originated from outside of Camden County College. Do not click links or open attachments unless you recognize the sender and know the content is safe.

Good morning Karen,

The City of Camden finally received the last \$10K required to perform our Spanish translations for our interactive historic mural. I know our 2023 final report was due but we have been unable to complete the work as I was still getting through the paperwork to secure the remaining funds needed to complete these. We are starting work now on translations and hope they will be done by summer. Will I be ok to submit our final report then? I emailed the arts email account back in January but didn't receive a response. Please advise, thanks.

Patrice Bassett M.A., C.M.R.
Acting Deputy Registrar of Vital Statistics
Records Manager
Office of the Municipal Clerk
City of Camden
520 Market St. Camden, NJ 08101
Office: 856-757-7049

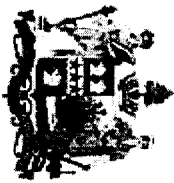

From: Patrice Bassett
Sent: Tuesday, January 23, 2024 2:00 PM
To: Arts <arts@camdenc.c.edu>
Subject: RE: PAST DUE - Final Report - 2023 Camden County Cultural & Heritage Commission - CHPP Regrant

Good morning,

The City of Camden needed to secure multiple grants to cover the cost of our Spanish translations. We just received the final monies needed through a Camden County Open Space grant. Because we were still in the process of gathering all monies needed, we have not completed this portion of our grant as of yet. Are we able to officially apply for an extension to this grant? Please advise, thanks.

Patrice Bassett M.A., C.M.R.
Acting Deputy Registrar of Vital Statistics
Records Manager

Office of the Municipal Clerk
City of Camden
520 Market St. Camden, NJ 08101
Office: 856-757-7049

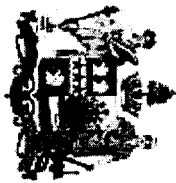

From: Arts <arts@camdencc.edu>
Sent: Tuesday, January 23, 2024 1:54 PM
To: Patrice Bassett <PaMcCart@ci.camden.nj.us>
Subject: PAST DUE - Final Report - 2023 Camden County Cultural & Heritage Commission - CHPP Regrant

CAMDEN COUNTY CULTURAL
AND HERITAGE COMMISSION



Please be aware that the Camden County Cultural and Heritage Commission has not received your Final Report Form for the 2023 County History Partnership Program you received through the Camden County Cultural & Heritage Commission.

If you have not completed the form, please do so by Thursday, January 25th as the final reporting information is due to the state. If you already submitted the final report electronically, please let us know immediately AND resend it to arts@camdencc.edu. If you already submitted your final report via the post office, please let us know immediately.

Attached you will find the Final Report Form for the 2023 County History Partnership Program regrant. **DEADLINE FOR SUBMISSION: January 12, 2024**

This report form is a fillable Word document. Please send electronically to: arts@camdencc.edu.

If mailing via post office, please send to:

Camden County Cultural & Heritage Commission @ Camden County College
Lincoln Hall, L-23
Camden County College
200 College Drive
Blackwood, NJ 08012

Please contact arts@camdencc.edu or call 856-227-7200, ext. 4494 with any questions you may have.

Camden County Cultural & Heritage Commission at Camden County College

arts@camdencc.edu

856-227-7200, ext. 4494

www.camdencc.edu/chc

CAM 2023-184

ATTACHMENT G

6.13.23

R-2

STATE OF NEW JERSEY
DEPARTMENT OF COMMUNITY AFFAIRS

DIVISION OF LOCAL GOVERNMENT SERVICES
GRANT APPROVAL FORM

This form must be filled out in its entirety and is intended to provide the Division with appropriate information to determine whether to approve a new or extended service. Please provide any additional information you believe will help the Division make an informed decision.

PLEASE EXPLAIN THE JUSTIFICATION FOR THE GRANT. PLEASE FULLY EXPLAIN COST ASSOCIATED WITH THE AWARD OF THE GRANT AS WELL AS ANY MATCHING FUNDS OR EMPLOYMENT OBLIGATIONS AS A TERM OF THE GRANT. PLEASE EXPLAIN THE BENEFITS OF THE GRANT OF THE MUNICIPALITY AND THE RESIDENTS. ATTACH THE GRANT APPLICATION AND GRANT AWARD LETTER.

This grant will cover the costs associated with the Spanish translations on the touch screen historic mural located in the lobby of City Hall and translations required for our online platform (website) as well. These remaining costs are estimated to be \$15,000 in total. This grant award is \$4,500 with no match requirement. We are working on identifying additional sources of funding to cover the remaining monies.

Our research about the importance of translating the kiosk information into Spanish is founded on the fact that nearly half the residents of the City of Camden are Spanish speakers. The 2020 US Census Quick Facts notes that 50.5% of Camden residents are Hispanic or Latino, and 42% speak Spanish at home. In Camden County, 17.6% of residents are Hispanic or Latino and 12.6% of the county population speaks Spanish at home. Given these statistics, the project planners believed that Spanish translations of the kiosk content would expand the audience for county history organizations and historic sites open to the public.

Our budget includes translation into Spanish but did not include integration of the translations into the Kiosk and Website by Night Kitchen Interactive which will cost \$15,000.

CITY OF CAMDEN
APR 25 PM 2:29

Information of key municipal employee or agent applying for grant and responsible for its use:

Name	Patrice Bassett
------	-----------------

Title	Records Manager CMR MA
Telephone Number	856-757-7049
Email	Pamccart.pm@gmail.com

If the grant is received and fully expended, what will the continuing financial obligations of the municipality be with respect to staffing, insurance, liability, operations, and/or maintenance?

After the first 3 years of coverage for operating costs associated with placing this historic data on the City of Camden website – the city will be required to pay for server updates from the city’s vendor (govdesigns) this may cause an increase of monthly costs by \$100.00 a month.

What will the source of funds be for the staffing, insurance, liability, operations, and /or maintenance?

Maintenance/updating will be performed by the vendor govdesigns (as they do with every other section of the City of Camden website). Any changes to the data displayed in this section will be addressed by Patrice Basset in conjunction with Information Technology and the Communications Department of the City of Camden.

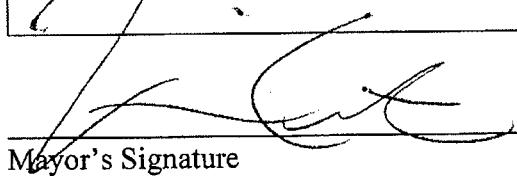

 Mayor's Signature

Date _____



 Business Administrator/Manager Signature

Date 6/14/23

Name, email and fax of contact person for this form:

For LGS use only:

Approved Denied

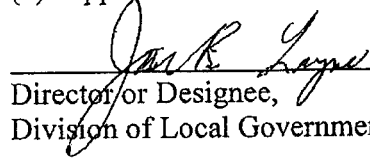

 Director or Designee,
 Division of Local Government Services

Date 6/21/23

Number Assigned _____



CITY OF CAMDEN — CITY COUNCIL ACTION REQUEST FORM

COUNCIL MEETING DATE: JUNE 13, 2023

TO: City Council
FROM: LUIS PASTORIZA, RMC CMR MUNICIPAL CLERK REGISTRAR

TITLE OF ORDINANCE/RESOLUTION: Resolution to accept Camden County Cultural and Heritage Commission grant funds in the amount of \$4,500 for completion of historic mural/website Spanish translations.

Point of Contact:	Patrice Bassett	Clerk - RMU	856-757-7049	pamccart@ci.camden.nj.us
	Name	Department- Division- Bureau	Phone	Email

ENDORSEMENTS

	Recommend Approval (Y/N)	Signature	Date	Comments
Responsible Department Director	Y		4/24/2023	
Supporting Department Director (if necessary)				
Director of Grants Management	Y		5/23/23	
Qualified Purchasing Agent				
Director of Finance			5/23/23	
Approved by:			5/24	
Business Administrator		Signature	Date	

CITY OF CAMDEN
GRANTS MANAGER
2023 APR 25 PM 2:29

Attachments (list and attach all available):

1. Waiver Request Form Attached for State DCA/DLGS Approval - (If applicable)¹
2. Certification of Funds²
3. Addition supporting documents.

"Walk-on" note: All walk-on legislation must be pre-approved by the Business Administrator. The Department Director and Contact Person are jointly responsible for delivering all necessary documents to the City Clerk for distribution at the Council Meeting.

Received by: _____
City Attorney

Signature _____ Date _____

¹ For Example: Form "A" - Request for approval of Employees Requiring Advice and Consent of Governing Body, Form "D" - Contract Request, Form "E" - Creation/Extension of Services, Form "G" - Grant Approval, Form "H" - Bond Ordinance or Contract Request, Form "I", "Best Price Insurance Contracting" Model Ordinance
² Mandatory for any financial commitment to the City or expenditure of City Funds.

Initial Report _____ Revised Report Closing Report _____

Bureau of Grants Management Grant Summary Form

Grant Status Code: G

(green - g; yellow - y; red - r)

Department: Municipal Clerk

Grant Administrator: Patrice McCarthy

Grant Administrator #: 757-7409

Project Name:		Heritage Tourism Interactive History Mural			
Grant/Funding Agency Program:		NJ Historical Commission County History Partnership Program (CHPP)			
Grant Federal CFDA or State GIMS Number:					
City Contract Date:		City Contract #:			
Application Resolution #:		Appropriation Code :			
Funding Source:					
Pass Through: <i>circle one</i>	Y or N	Source:	Camden County Cultural and Heritage Commission		
Amount of Grant:		\$4,500			
Local Match: <i>circle one</i>	Y or <input checked="" type="radio"/> N	Cash:		In-Kind:	
Budget Insertion Resolution # & Date:		Accepting Grant Resolution # MC:			
Term of Grant:	1/1/23 – 12/31/23	Location of Activity:	City-wide		
Date of Analysis:	4/17/23	Reviewed By:	Kelly Mobley		

Summary:

23-May-23: The Municipal Clerk's Office is seeking council authorization to accept \$4,500 from NJ Historical Commission County History Partnership Program (CHPP) to cover costs associated with the Spanish translations of the touch screen historic mural located in the lobby of City Hall. No match requirement.

17-Apr-23: The Municipal Clerk's Office is seeking council authorization to insert \$4,500 from NJ Historical Commission County History Partnership Program (CHPP) to cover costs associated with the Spanish translations of the touch screen historic mural located in the lobby of City Hall. No match requirement.

Time Lines:

Problematic Areas/Recommendations:

NJ Historical Commission County History Partnership Program (CHPP) 04/2023

EXECUTIVE SUMMARY

TITLE OF ORDINANCE/RESOLUTION: Resolution to accept Camden County Cultural and Heritage Commission grant funds in the amount of \$4,500 for completion of historic mural/website Spanish translations.

FACTS/BACKGROUND: (Executive level details. Short concise bullets)

- The City of Camden sought financial support to integrate Spanish translations of all 133 history content popups on the Heritage Tourism Interactive Touch Screen Kiosk (located in lobby)
- Translations will appear on both the kiosk itself and the City of Camden website where all the content is now available under the History tab
- Previous grant funds were not allowed in full which led the project planners to eliminate the Spanish translations for budgetary reasons
- This is the first infusion of funding needed to complete these translations

AMOUNT OF PROPOSED CONTRACT or TOTAL COST OF PROPOSAL:

- Total cost = \$15,000
- Additional grants are being sought to fund the remaining \$10,500. Granter is aware funds are not all in hand
- This award is \$4,500

IMPACT STATEMENT:

- If the City approves this resolution, we will be one step closer to covering the costs of history content Spanish translations
- If the City does not approve this, we will need to contact the granter and return these funds – this venture will likely be abandoned at that time.

SUBJECT MATTER EXPERTS/ADVOCATES:

- Patrice Bassett, Office of Municipal Clerk Records Management Unit
 - Attendance: N

COORDINATION:

- Our research about the importance of translating the kiosk information into Spanish is founded on the fact that nearly ½ the residents of the City of Camden are Spanish speakers.
- The 2020 US Census quick facts notes that 50.5% of Camden residents are Hispanic or Latino and 42% speak Spanish at home.
- Given these statistics, Spanish translations of the kiosk content and website would expand the audience for Camden County History organizations and historic sites open to the public.

Prepared by:

Patrice Bassett
Name

pmccart@ci.camden.nj.us x704
Phone/Email

**CAMDEN COUNTY CULTURAL
AND HERITAGE COMMISSION
AT CAMDEN COUNTY COLLEGE**



Patrice Bassett
City of Camden County College
520 Market Street
Camden, NJ 08101

RE: 2023 County History Partnership Program

December 2, 2022

Dear Ms. Bassett:

Congratulations! I am pleased to announce that the Camden County Cultural and Heritage Commission at Camden County College approved your application for funding from the New Jersey Historical Commission's County History Partnership Program (CHPP). The Commission has awarded your organization \$4,500 in FY23 CHPP grant dollars to support the advancement of public knowledge and preservation of New Jersey history.

Please complete the attached agreement and return it to Miranda Powell (mpowell@camdencc.edu) no later than December 31, 2022. Once we receive this documentation, the Commission can begin processing the first payment of your funding. Remember to adjust the financial pages to reflect the amount you have been awarded, which may differ from the amount you requested.

Please remember to keep detailed records as indicated in the initial proposal on all events and programs for which the funds are being utilized. In your final report, you will be required to provide documentation and narrative of how grant funds were spent. We also request that you share with us upcoming events and activities in 2023, so that we can assist with publicizing them on our social media pages.

In closing, the Commission asks that you provide recognition to the New Jersey Historical Commission and the Camden County Cultural and Heritage Commission in any promotional materials that you generate for programs utilizing these award funds. Information about the mandatory credit line is on page 4 of the contract.

Sincerely,

David Bruno
Executive Director
dbruno@camdencc.edu

CAMDEN COUNTY CULTURAL
AND HERITAGE COMMISSION
AT CAMDEN COUNTY COLLEGE



2023 Local History Funding Support
County History Partnership Program

GRANT AGREEMENT
Between the

CAMDEN COUNTY CULTURAL & HERITAGE COMMISSION
At Camden County College
And

City of Camden

For Grant Period from January 1 through December 31, 2023

Type of Grant: General Operating Support Special Project Support

Amount of Grant: \$ 4,500.00

GRANTEE INFORMATION:

Mailing Address: 501 Market Street Camden 08101
Street Town Zip Code

Grant Contact: Patrice Bassett Records Manager
Name Title

PAMCCART@CI.CAMDEN.NJ.US 856-757-7049
Email address Phone

Board President: NA E-Mail: _____

Organization Web-Site: www.ci.camden.nj.us

- Please Note: All contracts, report forms and payment vouchers will be sent to the mailing address listed above.

*State Legislative District # 5

Contract Stipulations, if any:

Please refer to the County History Partnership Program Guidelines for the list of allowable and unallowable expenses.

ATTACHMENT A
(page 1 of 2)

CONTRACTURAL OBLIGATIONS:

- A. You are bound by the Program revisions and the Revised Budget which you submit in Attachment B of this Agreement governing your grant.
- B. Any programming changes to grant-funded activities made after submission of this Agreement are subject to review and must receive prior approval from the Cultural & Heritage Commission's Executive Director.
- C. Any budget revision in excess of 10% of the entire grant award (total of column 1 revisions, page 2 of Attachment B) are subject to review and must receive prior written approval from the Executive Director of Camden County Cultural & Heritage Commission in order to qualify for reimbursement.

PAYMENT

You will receive two (2) payments:

- A. The first payment will be made after the satisfactory completion of this Grant Agreement.
- B. The final payment will be made upon completion of the Final Report, which includes documentation of expenditures.

REPORTS

- A. Report forms will be available four weeks prior to due date.
- B. Final reports require a break-out of figures in each budget category.
- C. You are required to provide documentation and narrative of how grant funds were spent.

WITHHOLDING GRANT AWARD PAYMENTS:

Grant award payments may be withheld if:

- A. Funds are not used as detailed in this contract or approved revisions
- B. Credit line guidelines are not adhered to
- C. Reports are not filed accurately and on time

ATTACHMENT A
(page 2 of 2)

ON-SITE MONITORING

- A. On-site monitoring visits may periodically be made by staff and commissioners of the Camden County Cultural & Heritage Commission
- B. Two (2) complimentary tickets and notices of free events funded by this grant should be sent to the Cultural and Heritage office four weeks prior to the event.

MANDATORY CREDIT LINE

- A. All grantees are required to credit the CCC&HC@CCC in all printed materials, releases, and announcements of the grantee regarding all activities to which NJHC funds contribute.
Suggested wording:

Funding provided by the Camden County Cultural & Heritage Commission at Camden County College, the officially designated county history agency of the New Jersey Historical Commission.

PROGRAM OBLIGATIONS

It is hereby understood and agreed that the Grant Application submitted by the grantee and upon which this grant was awarded is the basis upon which performance under this Agreement is specified, measured, and to be accounted for.

In signing this document, the grantee agrees to perform and comply with these specifications.
(Note: any proposed exceptions must be described below.)

The grantee hereby agrees that any planned programmatic revisions and/or budget revisions in excess of 10% of the total budget are subject to review and approval by the Executive Director of the Camden County Cultural & Heritage Commission.

Describe any changes to your program: _____

There are no changes. All aspects of the program as detailed in the grant application will be carried out. (as long as other funding sources come through)

ATTACHMENT B
(page 1 of 2)

Revised Budget

You only need to complete this page if your actual grant award differs from the amount you requested. The revised budget should reflect changes in dollar amounts but not in budget categories unless stipulated on the cover page of this contract. **IMPORTANT:** This budget will be used in all required reports.

LINE ITEM	TOTAL AMOUNT BUDGETED FY23	AMOUNT FROM GRANT
Personnel		
Salaries, Wages, benefits, Payroll Taxes		
Professional Services (contract services, such as consultants, accounts, auditors)	\$20,000	\$4,500
Professional development and training		
Professional dues, memberships		
Travel		
Facilities		
Mortgage interest		
Space rental		
Equipment purchase or rental		
HVAC & Utilities		
Facility maintenance/security		
Insurance		
Outreach		
Publicity and marketing		
Supplies		
Telephone/communication, postage		
Other (itemize)		
TOTAL	\$20,000	\$4,500

ATTACHMENT B (page 2 of 2)

CERTIFICATION

We certify that the above information is true and correct and that all expenditures are to be incurred solely for the purposes of this grant.

As representatives of this organization, we understand the importance of the Mandatory Credit Line and agree to all of the above terms of this GRANT AGREEMENT and its Attachments. We further certify to the truth of the representations placed therein.

Please ensure the following people review the grant contract and insert their names below. Signatures are not required.

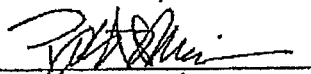
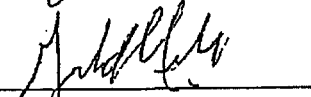
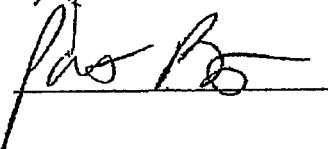
<u>Luis Pastoriza</u> Project/Program Director's Name		<u>12/8/2022</u> Date
<u>Gerald Seneski</u> Fiscal/Budget Officer's Name		<u>12/9/22</u> Date
<u>Patrice Bassett</u> Board President's Name(na) Project Lead's Name		<u>12/7/22</u> Date

RETURN THIS COMPLETED AGREEMENT BY EMAIL TO:

Miranda Powell, mpowell@camdencc.edu, by December 31, 2023

CAMDEN COUNTY CULTURAL & HERITAGE
COMMISSION@ CAMDEN COUNTY COLLEGE
P.O. Box 200 College Drive
Blackwood, NJ 08012
856-374-4201

R-34

DB:dh
03-12-24

**RESOLUTION AUTHORIZING AN APPLICATION FOR FUNDING FROM THE
URBAN ENTERPRISE ZONE AUTHORITY IN AN AMOUNT UP TO \$326,249
FOR THE 2025 FISCAL YEAR PROGRAM BUDGET**

WHEREAS, the City of Camden desires to submit an application to the Urban Enterprise Zone Authority for UEZ assistance in the amount up to THREE HUNDRED TWENTY-SIX THOUSAND, TWO HUNDRED FORTY-NINE DOLLARS (\$326,249.00) for the purpose of funding the Fiscal Year 2025 UEZ Administration budget of the City of Camden's Urban Enterprise Zone Authority; and

WHEREAS, City Council believes that the submission of such grant application is in the best interest of the residents of the City of Camden; now, therefore

BE IT RESOLVED, by the City Council of the City of Camden, that the proper officers be and are authorized to submit an application to the New Jersey Urban Enterprise Zone Authority for UEZ assistance in the amount up to THREE HUNDRED TWENTY-SIX THOUSAND, TWO HUNDRED FORTY NINE DOLLARS (\$326,249.00) for the funding of the Administration Budget of the City of Camden Urban Enterprise Zone Authority for Fiscal Year 2025, in accordance with all pertinent terms, conditions and requirements which may be established for such an application.

BE IT FURTHER RESOLVED, that pursuant to N.J.S.A. 52:27BBB-23, a true copy of this Resolution shall be forwarded to the State Commissioner of Community Affairs, who shall have ten (10) days from the receipt thereof to veto this Resolution. All notices of veto shall be filed in the Office of the Municipal Clerk.

Date: March 12, 2024

The above has been reviewed
and approved as to form.



DANIEL S. BLACKBURN
City Attorney

ANGEL FUENTES
President, City Council

ATTEST:

LUIS PASTORIZA
Municipal Clerk



CITY OF CAMDEN — CITY COUNCIL ACTION REQUEST FORM

CITY OF CAMDEN
FINANCE DEPARTMENT

3-12-24

2024 FEB -8 AM 10: 24 COUNCIL MEETING DATE: MMMM, DD, YY

TO: City Council
FROM: Dr. Edward C. Williams, AICP, PP, CSI, Director

TITLE OF ORDINANCE/RESOLUTION:: RESOLUTION AUTHORIZING an Application request from the Urban Enterprise Zone Assistance Fund in an amount not to exceed \$326,249.00 from the NJ Department of Community Affairs for a grant entitled " UEZ Admin Budget

Point of Contact:	Joe Thomas Planning and Development	968-3531	jothomas@ci.camden,nj.us
	Name	Department- Division- Bureau	Phone Email

ENDORSEMENTS

	Recommend Approval (Y/N)	Signature	Date	Comments
Responsible Department Director	Y		1/30/24	
Supporting Department Director (if necessary)				
Director of Grants Management	Y		2/7/24	
Qualified Purchasing Agent				
Director of Finance			2/9	
Approved by: Business Administrator			2/22	

Attachments (list and attach all available):

1. Waiver Request Form Attached for State DCA/DLGS Approval - (If applicable)¹
2. Certification of Funds²
3. Addition supporting documents.

FEB 29 2024

¹ For Example: Form "A" - Request for approval of Employees Requiring Advice and Consent of Governing Body, Form "D" - Contract Request, Form "E" - Contract Extension of Services, Form "G" - Grant Approval, Form "H" - Bond Ordinance or Contract Request, Form "I", "Best Price Insurance Contracting" Model Ordinance

² Mandatory for any financial commitment to the City or expenditure of City Funds.

EXECUTIVE SUMMARY

TITLE OF ORDINANCE/RESOLUTION: **RESOLUTION** AUTHORIZING an Application request from the Urban Enterprise Zone Assistance Fund in an amount not to exceed \$326,249.00 from the NJ Department of Community Affairs for a grant entitled " UEZ Admin Budget

FACTS/BACKGROUND: (Executive level details. Short, concise bullets)

- To allow the City of Camden to fund local business expansion and job creation
- UEZ admin budget to fund staff and continued projects

AMOUNT OF PROPOSED CONTRACT or TOTAL COST OF PROPOSAL: \$326,249.00

IMPACT STATEMENT:

- Funding will reimburse the City of Camden expenses used in Fiscal Year 2025 toward admin
- To add additional funds to our overall budget
- If not approved, the funds will be returned to UEZAF

SUBJECT MATTER EXPERTS/ADVOCATES:

- Joe Thomas Planning & development Urban Enterprise Zone.

COORDINATION:

- The entire City of Camden is impacted

Prepared by:

Joe Thomas 856-968-3531

Name

Phone/Email

Initial Report Revised Report _____ Closing Report _____
Bureau of Grants Management Grant Summary Form
Grant Status Code: G
(green - g; yellow - y; red - r)

Department: Planning and Development

Grant Administrator: Joseph Thomas

Grant Administrator #: 968-3531

Grant/Project Name:			Urban Enterprise Zone Authority (UEZA Administration 25)		
Grant #:			UEZA FY 25 (July 1 2024 – June 30, 2025)		
City Contract Date:			City Contract #:		
Application Resolution #:			Appropriation Code :		
Funding Source:			Urban Enterprise Zone Authority		
Pass Through:	Y	N	Source:	City	
Amount of Grant:			\$326,249.00		
Local Match:	Y	N	Cash:		In-Kind:
Budget Insertion Resolution # & Date:			Accepting Grant Resolution # MC:		
Term of Grant:		7/1/24 – 6/30/25		Location of Activity:	
Date of Analysis:		2-Feb-24		Reviewed By:	Kelly Mobley

Summary:

2-Feb-24: The Department of Planning and Development - Camden UEZA Office is requesting council authorization for administrative cost associated with administering the Camden UEZA Program. The requested budget is as follows for fiscal year 2025:

Personnel:	\$211,902.00
Fringe:	\$11,945.00
Materials and Supplies:	\$3,200.00
Marketing/Advertisement:	\$51,002.00
Travel:	\$1,200.00
Equipment:	\$12,000.00
Hired Services:	\$35,000.00
Total:	\$326,249.00

Up to 100% of the UEZA Coordinator's salary and other City Staff salaries will be changed to the grant for time allocated to this program. This includes two hires (Admin Secretary and Program Monitor)

Time Lines: July 1, 2024 – June 30, 2024

The resolution is needed prior to presentation before the State UEZA Board in April.

Problematic Areas/Recommendations: Any funding not utilized once awarded will be returned to the State and made available for future use.

ATTACHMENT G

**STATE OF NEW JERSEY
DEPARTMENT OF COMMUNITY AFFAIRS**

**DIVISION OF LOCAL GOVERNMENT SERVICES
GRANT APPROVAL FORM**

This form must be filled out in its entirety and is intended to provide the Division with appropriate information to determine whether to approve a new or extended service. Please provide any additional information you believe will help the Division make an informed decision.

PLEASE EXPLAIN THE JUSTIFICATION FOR THE GRANT. PLEASE FULLY EXPLAIN COST ASSOCIATED WITH THE AWARD OF THE GRANT AS WELL AS ANY MATCHING FUNDS OR EMPLOYMENT OBLIGATIONS AS A TERM OF THE GRANT. PLEASE EXPLAIN THE BENEFITS OF THE GRANT OF THE MUNICIPALITY AND THE RESIDENTS. ATTACH THE GRANT APPLICATION AND GRANT AWARD LETTER.

THE CITY OF CAMDEN TO APPLY FOR FUNDING FROM THE URABN FOR THE AMOUNT OF \$326,249.00 for THE FISCAL YEAR ADMIN BUDGET 2025

Information of key municipal employees or agent applying for grants and responsible for its use:

Name	Joe Thomas
Title	Economic Development Rep / UEZ Coordinator
Telephone Number	856-968-3531
Email	jothomas@ci.camden.nj.us

If the grant is received and fully expended, what will the continuing financial obligations of the municipality be with respect to staffing, insurance, liability, operations, and/or maintenance?

NA

What will the source of funds be for staffing, insurance, liability, operations, and /or maintenance?

Funds from the UEZ will provide administration resources, fringe and other operating expense to effectively maintain the program

Mayor's Signature

Date _____

Business Administrator/Manager Signature

Date _____

Name, email and fax of contact person for this form:

For LGS use only:

Approved Denied

Director or Designee,
Division of Local Government Services

Date _____

Bureau of Grants Management Grant Summary Form**Grant Status Code: G**

(green - g; yellow - y; red - r)

Department: Development and Planning (Housing Services)

Grant Administrator: Joe Thomas

Grant Administrator #: 968-3531

Community De- v. Corp

Grant/Project Name:			Urban Enterprise Zone Authority (UEZA administration 2025)			
Grant #:			UEZA			
City Contract Date:						
Application Resolution #:				Appropriation Code		
Funding Source:			UEZ			
Pass-Through:	Y	N	Source:	City		
Amount of Grant:			\$326,249.00			
Local Match:	Y	N	Cash:		In-Kind:	
Budget Insertion Resolution # & Date:			Accepting Grant Resolution # MC:			
Term of Grant:			TBD		Location of Activity:	
Date of Analysis:			1/30/2024		Reviewed By: Joe Thomas	

Summary:

1/30/2024. The Department of Development and Planning/UEZ requests counsel authorization to apply for funding not to exceed \$326,249.00 to the NJ Urban Enterprise Zone Authority for administration costs associated with administration budget for the Camden Strong UEZ

**New Jersey Department of Community Affairs
APPLICATION FOR GRANT FUNDS**

STANDARD GRANT COVER SHEET

2022-08004-1819

1. DCA Program to Which Applicant is Applying: Urban Enterprise Zone - Camden 2022			
2. Name of Applicant Agency Camden City			
3. Street Address City Hall 520 Market Street			
City Camden	State New Jersey	Zip Code 08101-5120	County Camden
4. Official Contact Person Ms. Kelly Mobley		Title Coordinator for Federal a	
5. Program Contact Person Mr. Joseph Thomas		Title UEZ Coordinator	
Phone number (856) 757-7689		Phone Number (856) 968-3531	
6. Proposed Project/Grant Title Camden UEZ Admin Budget 2025			
Program Type Administrative Budget: Camden UEZ Admin Budget 2025			
7. Total Cost of the Project \$326,249	8. Requested Amount \$326,249		9. Funds from Other Sources \$0
10. Project Location (if Different from Applicant Agency) City of Camden			
Street Address 520 Market Street			
City Camden	State New Jersey	Zip 08101-5120	Room Number 222
11. Vendor Number 216000418-09		12. Employer ID 216000418	
		13. Tax Exempt ID 216000418	
14. Area(s) Benefiting:			
15. Briefly describe the project for which you are seeking funds. To provide funds for continued growth toward the municipality's projected Fiscal Year total 2025 total Urban Enterprise Zone administrative budget for the allocation ending in 2025			

16. a. Will any member of the Board of Directors/Trustees receive any direct or indirect personal or monetary gain from the funding of this grant?

Yes No

b. Does any member of the Board of Directors/Trustees serve on any board, council commission, committee or task force which has regulatory or advising influence on the funding program? Yes No

If yes, please describe:

17. Fiscal Contact Person

Mr. Gerald C Seneski

Title

Financial Officer

Phone Number

(856) 757-7852

18. Agency Fiscal Year

7/1 to 6/30

19. Name of CPA Firm Appointed by Grantee

Bowman & Co. LLP

20. **Certification:** The applicant certifies that to the best of his/her knowledge and belief all data supplied in this application and attachments are true and correct. The document has been duly authorized by the governing body of the applicant and further understands and agrees that any grant received as a result of this application shall be subject to the grant conditions and other policies, regulation, and rules issued by the New Jersey Department of Community Affairs which include provisions described in grant applications instructions.

Name and Title of Applicant (Print)

Signature of Applicant

Date of Application

OBJECTIVES

Objective Number: 1

Short Description: UEZ Admin Budget 2025

Detailed Description

Despite the challenging economic climate, the Camden UEZ Office is committed to increasing its membership. Camden's goal for 2024 is to increase membership by 20% (roughly 20 members). The second goal is successfully implementing the projected projects identified in this budget. These projects will significantly impact the local economy by providing much-needed services, job creation, and small businesses.

Methods

Membership will be increased by continuing successful practices such as print advertising, site visits, direct mailings, phone calls, and the Internet. Camden anticipates increasing membership recruitment via the new Advertising Campaign. With the NJUEZA's support, Camden plans to implement these referenced projects. Some projects (years 3 or 4) are established and will build on past success. The others are partnerships with viable Camden agencies with proven capacity.

Evaluation

Membership goals will be tracked weekly and re-evaluated every quarter. Projects are also tracked on a quarterly base by the NJUEZA via Sage. Monthly project reports will be submitted to the Camden office.

Application Program Component: Camden UEZ Admin Budget 2025

Scope of Services

This fund application is intended to support the cost associated with the Camden Fiscal Year 2025 Administrative Budget. These costs include salary for personnel. In addition, the funds will be applied to standard operating expenses, which include advertising, membership, equipment, auto, and consumable office supply costs. The Camden UEZ Program staff has Joe Thomas (UEZ Coordinator)-Who is responsible for the daily oversight and administration of the Camden. Program and reports to the City of Camden Director of Planning and Development (Edward William). Mr. Thomas is responsible for promoting the program and encouraging the expansion of existing and

attraction of new business to the City of Camden. His duties include submitting and administering. All fund applications, monitoring UEZ-funded projects, submitting periodic reports to the NJUEZA, conducting site visits, approving all membership certifications and recertification, and processing payment requests, among other duties. Mr. Thomas is also responsible for monitoring UEZ membership and liaising between the business community and the local UEZ Office. Mr. Thomas conducts daily site visits, registers new UEZ members, re-certifies existing members, identifies recent business locations, and assists new businesses with establishing a Camden location (from start to finish). The Camden UEZ continues to increase local employment, provide essential gap funding for non-conventional projects, and provide resources to secure commercial corridors. The UEZ has become one of Camden's most important economic development tools. UEZ funding has been used to connect. Billions in past private, state, and federal investments and to leverage millions of anticipated. State and federal monies. The Camden UEZ 2024 Administrative Budget will be a guide tool for the upcoming year. It sets the goals for 2024 and provides a benchmark to measure progress. Without NJUEZA's funding commitment, the

Camden UEZ Program will not be able to operate. The City of Camden does not have sufficient funding in place to support the staff salaries or other associated operating costs.

Budget Detail

Administrative Budget: Camden UEZ Admin Budget 2025

Camden City

UEZ Assistance Anticipated UEZ Assistance Municipal Funds Other Funds Total Budget

Budget Category	UEZ Assistance	Anticipated UEZ Assistance	Municipal Funds	Other Funds	Total Budget
ADM - Personnel					
Salaries/Wages					
UEZ Coordinator Joe Thomas FTE.1.0	\$107,998.00				\$107,998.00
Administrative Secretary 1.0	\$58,004.00				\$58,004.00
Program Monitor 1.0	\$45,900.00				\$45,900.00
Minor Category Sub-Total	\$211,902.00	\$0.00	\$0.00	\$0.00	\$211,902.00
Fringe Benefits					
Fringe Benefits	\$11,945.00				\$11,945.00
Minor Category Sub-Total	\$11,945.00	\$0.00	\$0.00	\$0.00	\$11,945.00
Other					
Material and Supplies	\$3,200.00				\$3,200.00
Minor Category Sub-Total	\$3,200.00	\$0.00	\$0.00	\$0.00	\$3,200.00
Major Category Sub-Total	\$227,047.00	\$0.00	\$0.00	\$0.00	\$227,047.00
ADM - Operating Cost					
Advertising					
Marketing and Advertising	\$51,002.00				\$51,002.00
Minor Category Sub-Total	\$51,002.00	\$0.00	\$0.00	\$0.00	\$51,002.00
Travel					
Cost associated with Conferences	\$1,200.00				\$1,200.00
Minor Category Sub-Total	\$1,200.00	\$0.00	\$0.00	\$0.00	\$1,200.00
Equipment Purchase					
Equipment	\$12,000.00				\$12,000.00
Minor Category Sub-Total	\$12,000.00	\$0.00	\$0.00	\$0.00	\$12,000.00
Major Category Sub-Total	\$64,202.00	\$0.00	\$0.00	\$0.00	\$64,202.00

Urban Enterprise Zone - Camden 2022

PROJECT INFORMATION

Business Recruitment Plan for New Fiscal Year

Membership will be increased by continuing successful practices such as print advertising, site visits, direct mailings, phone, and the Internet. Camden anticipates increasing membership recruitment via the new Advertising Campaign. With the NJUEZA's support, Camden plans to implement these referenced projects. Some projects (years 3 or 4) are established and will build on past success. The others are partnerships with viable Camden agencies with proven capacity.

Urban Enterprise Zone - Camden 2022
FUTURE UEZ PROPOSALS

Name of Proposal The 2025 Commercial Facade Improvement Program

Description of Proposal

The 2025 Commercial Facade Improvement Program fosters commercial revitalization and economic development and improves neighborhood conditions. This program helps to develop a more vibrant, walkable, mixed-use commercial district. Additionally, the program transforms commercial communities into destinations for residents and out-of-area customers, increases employment for area residents, increases the number of commercial opportunities, and enhances the neighborhood's appearance. Lastly, this program builds upon previously funded efforts targeting the commercial corridor with clean and safe services, gateway signage, neighborhood identification banners, and the recently constructed road improvements.

Estimated total cost of proposal

Estimated UEZ cost of proposed 500,000.00.

Urban Enterprise Zone - Camden 2022
FUTURE UEZ PROPOSALS

Estimated UEZ cost of proposal \$500,000.00

Anticipated number of jobs created 15

Anticipated impact on municipal tax base

Standard's buildings in Camden are located in the Gateway Redevelopment Zone and are potentially subject to the eminent domain at the behest of the Master Re developer, Campbell Soup Co. ("CSC"). To avoid eminent domain and to be able to remain and continue to operate in its current facilities, Standard has agreed with CSC and the Camden Redevelopment Agency ("CRA") Perform specific cosmetic improvements to its building to make it fit better architecturally with the office park, which is expected to be constructed in the Zone and close to that building. Provided these improvements are made, CSC, as the Master developer, has agreed not to request or approve the taking of Standard's buildings. The benefit, therefore, to Standard, from completing the improvements is a fulfillment of the agreement with C.

Can measurable be quantified? Yes No N/A

Urban Enterprise Zone - Camden 2022
ATTACHMENTS (ADMINISTRATIVE BUDGET)

1a. Fully executed City Council Resolution

I will...

- Mail this attachment
- Hand deliver this attachment

1b. Zone Board Resolution

I will...

- Mail this attachment
- Hand deliver this attachment

2 . Agreement(s) between the Zone and Firm

I will...

- Upload this attachment
- Mail this attachment
- Fax this attachment
- Hand deliver this attachment
- Not applicable

Urban Enterprise Zone - Camden 2022
SCHEDULE A: PERSONNEL

Name of Employee	Joseph Thomas
Position/Title	uez Coordinator FTE. 1.0
Date of Hire	1/1/2021
Eligible for Overtime?	Yes <input type="checkbox"/> No <input checked="" type="checkbox"/>
	<input checked="" type="checkbox"/> Full Time Part Time
Standard Weekly Work Hours	35
Number of Weekly Hours Dedicated to UEZ	35
Annual Salary	\$97,998.00
Annual Salary Requested from UEZ	\$97,998.00
Municipal Salary subsidy (if applicable)	
Annual Fringe Benefits	\$6,950.00
Annual Fringe Benefits Requested from UEZ	\$6,950.00
Submit Job Description	435227-289059-joe e.docx
I will...	Upload this attachment Mail this attachment Fax this attachment <input checked="" type="checkbox"/> Hand deliver this attachment Not applicable
Submit Resume	435227-289055-joe.docx
I will...	Upload this attachment Mail this attachment Fax this attachment <input checked="" type="checkbox"/> Hand deliver this attachment Not applicable

Urban Enterprise Zone - Camden 2022
SCHEDULE A: PERSONNEL

Name of Employee	TBD
Position/Title	Admin Secretary
Date of Hire	7/1/2024
Eligible for Overtime?	Yes No
	<input checked="" type="checkbox"/> Full Time Part Time
Standard Weekly Work Hours	35
Number of Weekly Hours Dedicated to UEZ	35
Annual Salary	\$58,004.00
Annual Salary Requested from UEZ	\$58,004.00
Municipal Salary subsidy (if applicable)	
Annual Fringe Benefits	\$6,950.00
Annual Fringe Benefits Requested from UEZ	\$6,950.00
Submit Job Description	435228-289059-administrative secretary jo
I will...	Upload this attachment Mail this attachment Fax this attachment <input checked="" type="checkbox"/> Hand deliver this attachment Not applicable
Submit Resume	
I will...	Upload this attachment Mail this attachment Fax this attachment Hand deliver this attachment <input checked="" type="checkbox"/> Not applicable

Urban Enterprise Zone - Camden 2022
SCHEDULE A: PERSONNEL

Name of Employee	TBD
Position/Title	Program Monitor
Date of Hire	7/1/2024
Eligible for Overtime?	Yes <input type="checkbox"/> No <input checked="" type="checkbox"/>
	<input checked="" type="checkbox"/> Full Time Part Time
Standard Weekly Work Hours	35
Number of Weekly Hours Dedicated to UEZ	35
Annual Salary	\$45,900.00
Annual Salary Requested from UEZ	\$45,900.00
Municipal Salary subsidy (if applicable)	
Annual Fringe Benefits	\$6,950.00
Annual Fringe Benefits Requested from UEZ	\$6,950.00
Submit Job Description	435229-289059-program monitor.docx
I will...	Upload this attachment Mail this attachment Fax this attachment <input checked="" type="checkbox"/> Hand deliver this attachment Not applicable
Submit Resume	
I will...	Upload this attachment Mail this attachment Fax this attachment Hand deliver this attachment <input checked="" type="checkbox"/> Not applicable

Urban Enterprise Zone - Camden 2022

CERTIFICATION SHEETS

<i>If your Agency type is not required to answer any of the questions below, click the N/A radio button</i>				
		<input checked="" type="checkbox"/> Yes	<input type="checkbox"/> No	<input type="checkbox"/> N/A
1.	I certify that this agency is not delinquent on any Federal or State debt.	<input checked="" type="checkbox"/>	<input type="checkbox"/>	<input type="checkbox"/> N/A
2.	I understand that payments from NJDCA will depend on our submission of all required grant reports.	<input checked="" type="checkbox"/>	<input type="checkbox"/>	<input type="checkbox"/> N/A
3.	I certify that neither members of our organization's governing body nor members of their families will receive any direct or indirect personal or monetary gain from the funding of this grant.	<input checked="" type="checkbox"/>	<input type="checkbox"/>	<input type="checkbox"/> N/A
4.	I certify that our organization's Certification of System for Award Management(SAM) is valid and current.	<input checked="" type="checkbox"/>	<input type="checkbox"/>	<input type="checkbox"/> N/A
5.	I certify that neither members of our organization's governing body nor members of their families serve on any board, council, commission, committee, or task force that has regulatory authority or advising influence on the funding program.	<input checked="" type="checkbox"/>	<input type="checkbox"/>	<input type="checkbox"/> N/A
	If no, please explain:			
Non-government Agencies only—				
6.	If our agency has not received funds from NJDCA for the current State Fiscal Year, I will submit our organization's most recent audit.	<input type="checkbox"/>	<input type="checkbox"/>	<input checked="" type="checkbox"/> N/A
7.	The information contained in the Board of Directors list in our Agency Information is adequate and up-to-date at the time of this application.	<input type="checkbox"/>	<input type="checkbox"/>	<input checked="" type="checkbox"/> N/A

CERTIFICATION SHEETS

ATTACHMENTS	
Certification Regarding Debarment and Suspension - Schedule G	
I will upload this attachment <input type="checkbox"/>	Not applicable <input checked="" type="checkbox"/>
Certification Regarding Lobbying - Schedule H	
I will upload this attachment <input type="checkbox"/>	Not applicable <input checked="" type="checkbox"/>
Resolution - Schedule I Or Local Match Only - Schedule I	
I will upload this attachment <input type="checkbox"/>	Not applicable <input checked="" type="checkbox"/>
IRS Determination Letter (New Applicants, Non-profit, Non-government only)	
I will upload this attachment <input type="checkbox"/>	Not applicable <input checked="" type="checkbox"/>
Organizational Chart (Non-government only)	
I will upload this attachment <input type="checkbox"/>	Not applicable <input checked="" type="checkbox"/>
Application Cover Page	
I will upload this attachment <input type="checkbox"/>	Not applicable <input checked="" type="checkbox"/>
Please upload any third party agreement(s) that may be pertinent to this grant. (see application instructions for specific details)	

Account	Address	Balance 3rd Quarter	4th Quarter Bill	4th Quarter Interest	Balance 12/31/23	Paid 01/26/24	Interest 01/31/24	Request Adjustment	Balance Forward
080238710	City Hall - 520 Market Street	7,559.05	1,408.00	332.60	9,299.65	(1,408.00)	114.82		8,006.47
080275555	Comm Ctr - 1035 Reeves Ave (Cramer Hill)	7,595.71	88.00	228.33	7,912.04	(88.00)	77.50		7,901.54
080264732	Comm Ctr - 1000 North 6th Street (North Camden)	1,502.85	176.00	66.07	1,744.92	(176.00)	22.83		1,591.75
080283526	Comm Ctr - 1151 Haddon Ave (MLK Center)	750.51	88.00	32.99	871.50	(88.00)	11.40		794.90
080264534	Comm Ctr - 1200 Merrimac (Melandra Hall)	750.51	88.00	32.99	871.50	(88.00)	11.40		794.90
080264161	Comm Ctr - 2500 Morgan Blvd	750.51	88.00	32.99	871.50	(88.00)	11.40		794.90
080259401	Comm Ctr - 701 Carl Miller Blvd (Isabel Miller)	12,232.65	264.00	450.69	12,947.34	(264.00)	153.67		12,837.01
080247596	Comm Ctr - 713 Broadway	750.51	88.00	32.99	871.50	(88.00)	11.40		794.90
080315377	Recreation - 1170 North 29th Street (Cramer Hill Boys Club)	1,405.14	54.75	59.64	1,519.53	(54.75)	20.49		1,485.27
080287303	DPW - 10-11 Street Garage	11,386.81	264.00	438.51	12,089.32	(264.00)	149.57		11,974.89
080223936	DPW - 121 Marlton Pike Garage	750.51	88.00	32.99	871.50	(88.00)	11.40		794.90
080006265	DPW - 443 Kaighn Ave Garage	616.00	264.00	9.36	899.36	(264.00)	9.36		634.72
080283294	Fire - 1115 Kaighn	750.51	88.00	32.99	871.50	(88.00)	11.40		794.90
080252075	Fire - 1301 Broadway	1,502.85	176.00	66.07	1,744.92	(176.00)	22.83		1,591.75
080280605	Fire - 15 North 27th Street	1,502.85	176.00	66.07	1,744.92	(176.00)	22.83		1,591.75
080239122	Fire - 4 North 3rd Street	750.51	88.00	32.99	871.50	(88.00)	11.40		794.90
080273642	Fire - 901 North 27th Street	918.28	88.00	40.23	1,046.51	(88.00)	13.95		972.46
080260896	Housing Authority - Chelton Terrace Management Office	1,046.90	54.75	44.77	1,146.42	(54.75)	15.48		1,107.15
080287279	Police - 800 Federal Street	7,936.78	704.00	346.61	8,987.39	(704.00)	120.56		8,403.95
280279532	Police Stable - NE Federal & Dudley	750.51	88.00	32.99	871.50	(88.00)	11.40		794.90
080021363	215 S Carman / E 17th St (Matrix Admiral Wilson Development)	3,757.68	440.00	165.18	4,362.86	(440.00)	57.08		3,979.94
080173487	Foreclosure - 1134 Langham Ave (Foreclosed 11/13/2019)	2,877.42	54.75		2,932.17	(54.75)		(2,877.42)	0.00
080177256	Foreclosure - 1438 Ormond Ave (Foreclosed 11/13/2019)	1,820.06	54.75	65.45	1,940.26	(54.75)	22.44	(1,907.95)	0.00
080108574	Foreclosure - 512 North 9th Street (Foreclosed 11/13/2019)	5,343.04	54.75	131.07	5,528.86	(54.75)	44.52	(5,518.63)	0.00
080164569	Foreclosure - 2209 Sewell Street (Foreclosed 11/13/2019)	5,922.73	54.75	139.29	6,116.77	(54.75)	47.29	(6,109.31)	0.00
080186984	Foreclosure - 1187 Sycamore Street (Foreclosed 09/23/2008)	5,962.37	54.75	140.64	6,157.76	(54.75)	47.74	(6,150.75)	0.00
		86,893.25	5,135.25		95,083.00	(5,135.25)	1,054.16	(22,564.06)	68,437.85

DB:MBS
03-12-24

RESOLUTION APPROVING A LICENSE AGREEMENT BETWEEN THE CITY OF
CAMDEN AND RYAD A. HASSON, 835 N. 7TH ST FOR THE ENCLOSURE
EXTENSION IN THE RIGHT OF WAY

WHEREAS, Mr. Hasson, the owner of 835 N. 7th St. enclosed an overhang onto
the City right-of-way; and

WHEREAS, Mr. Hasson desires to maintain said right of way extension; and

WHEREAS, the City Council of the City of Camden is of the opinion that it is in the
best interest of the City of Camden to enter into a License Agreement terminable at the will
of the Licensor and establishing the terms of the use of said property and requiring the
Licensee to completely indemnify the City of Camden and provide adequate general liability
insurance naming the City of Camden as an additional insured; now, therefore

BE IT RESOLVED by the City Council of the City of Camden that the City of
Camden is authorized to enter into a License Agreement with Mr. Ryad Hasson to permit
the enclosed overhang at 835 N. 7th St. to extend onto the City's right of way.

BE IT FURTHER RESOLVED that pursuant to N.J.S.A. 52:27BBB-23, a true copy
of this Resolution shall be forwarded to the Chief Operating Officer, who shall have ten
(10) days from the receipt thereof to approve or veto this Resolution. Notice of approval
or veto shall be filed in the office of the Municipal Clerk.

On Motion: _____

Date: March 12, 2024

The above has been reviewed
and approved as to form.

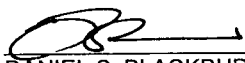

DANIEL S. BLACKBURN
City Attorney

ANGEL FUENTES
President, City Council

ADOPTED: _____

ATTEST: _____
LUIS PASTORIZA
Municipal Clerk



CITY OF CAMDEN — CITY COUNCIL ACTION REQUEST FORM

COUNCIL MEETING DATE: MARCH 12, 2024

TO: City Council
FROM: Dr. Edward Williams, PP, AICP, CSI, AHP, CZO, CPZBS

TITLE OF ORDINANCE/RESOLUTION: Resolution approving a license agreement between the City of Camden and Ryad A Hasson, 835 N. 7th St for the enclosure extension in the right of way

Point of Contact:	Dr. Ed Williams	DPD- P& Z	7135	edwillia@ci.camden.nj.us
	Name	Department-Division-Bureau	Phone	Email

ENDORSEMENTS

	Recommend Approval (Y/N)	Signature	Date	Comments
Responsible Department Director	Y		2/21/24	
Supporting Department Director (if necessary)				
Director of Grants Management				
Qualified Purchasing Agent				
Director of Finance				

Approved by:
Business Administrator

Signature

Date

Attachments (list and attach all available):

1. Waiver Request Form Attached for State DCA/DLGS Approval - (If applicable)¹
2. Certification of Funds²
3. Addition supporting documents.

“Walk-on” note: All walk-on legislation must be pre-approved by the Business Administrator. The Department Director and Contact Person are jointly responsible for delivering all necessary documents to the City Clerk for distribution at the Council Meeting.

Received by:

FEB 29 2024

¹ For Example: Form “A” - Request for approval of Employees Requiring Advice and Consent of Governing Body, Form “D” - Contract Request, Form “E” - Creation/Extension of Services, Form “G” - Grant Approval, Form “H” - Bond Ordinance or Contract Request, Form “I”, “Best Price Insurance Contracting” Model Ordinance

² Mandatory for any financial commitment to the City or expenditure of City Funds.

City Attorney

Signature

Date

EXECUTIVE SUMMARY

TITLE OF ORDINANCE/RESOLUTION: Resolution approving a license agreement between the City of Camden and Ryad A Hasson, 835 N. 7th St for the enclosure extension in the right of way

FACTS/BACKGROUND: (Executive level details. Short concise bullets)

- Relevant facts/history. 5Ws. Include geography if applicable.
 - **Mr. Hasson, owner of 835 N. 7th St enclosed a overhang into the city right of way. Mr. Hasson desires to maintain said right of way extension.**
 - **The DPD recommends the approval conditioned upon the owner providing and maintaining proof of insurance naming the City – additional insured.**
- Time constraints, if any. (Why does the Council need to act now?)
 - **There are no time constraints for this proposed action.**
- How was the value of the transaction obtained (if applicable?) **Not applicable**

AMOUNT OF PROPOSED CONTRACT or TOTAL COST OF PROPOSAL: Not applicable

IMPACT STATEMENT:

- What will happen if the City Council approves this legislation? or,
 - **It will allow the continuance of the enclosure extension.**
- What changes and by how much if the City Council approves this proposal?
 - **There are no particular cost impact to this legislation to the city.**
- Why Should the City Council approve this legislation?
 - **The approval of this action will allow the continuance of this extension.**
- What will happen if the City Council does not approve this legislation?
 - **The owner will have to remove the extension.**

SUBJECT MATTER EXPERTS/ADVOCATES:

- **Dr. Ed Williams - DPD**
 - Attendance: (Y/N/Tentative). Confirmed? **Will be in attendance**
- Name, Organization 2.
 - Attendance: (Y/N/Tentative). Confirmed?
- Additional as required...

COORDINATION:

- Who is impacted/has action if the legislation is passed? Key government officials – Code Enforcement, Planning and Development, City residents, Community Development, Economic Development, and Private developers.

Prepared by:

7135

Edwillia@ci.camden.nj.s

Name

Phone/Email

STATE FARM FIRE AND CASUALTY COMPANY
 A STOCK COMPANY WITH HOME OFFICES IN BLOOMINGTON, ILLINOIS

DECLARATIONS

Po Box 2915
 Bloomington IL 61702-2915

Named Insured

001433 3123
 HASSAN, RYAD A
 DBA FRITZ'S FOOD MARKET
 835 N 7TH ST
 CAMDEN NJ 08102-1844

M-17-09F1-FA3F F Z

Policy Number	90-CW-K462-6	
Policy Period	Effective Date	Expiration Date
12 Months	MAY 12 2023	MAY 12 2024
The policy period begins and ends at 12:01 am standard time at the premises location.		

Agent and Mailing Address

CHRIS CARAISCO
 8701 W CHESTER PIKE
 UPPER DARBY PA 19082-1236

PHONE: (610) 789-3400



ST-2
 01/21/2001

Food Shop Policy

Automatic Renewal - If the policy period is shown as 12 months, this policy will be renewed automatically subject to the premiums, rules and forms in effect for each succeeding policy period. If this policy is terminated, we will give you and the Mortgagee/Lienholder written notice in compliance with the policy provisions or as required by law.

Entity: Individual

POLICY PREMIUM	\$ 3,769.00	Claim Record
NJ Surcharge	\$ 19.00	
Total Amount	\$ 3,788.00	

Discounts Applied:
 Years in Business
 Protective Devices
 Dwg/Apt

Prepared
 MAY 30 2023
 CMP-4000

© Copyright, State Farm Mutual Automobile Insurance Company, 2008
 Includes copyrighted material of Insurance Services Office, Inc., with its permission.

Continued on Reverse Side of Page

Page 1 of 6

013141 290 I
 N 1R,D9,N5,M2

530-686 a.2 05-31-2011 (013231c)

DECLARATIONS (CONTINUED)

Food Shop Policy for HASSAN, RYAD A
 Policy Number 90-CW-K462-6

SECTION I - PROPERTY SCHEDULE

Location Number	Location of Described Premises	Limit of Insurance* Coverage A - Buildings	Limit of Insurance* Coverage B - Business Personal Property	Seasonal Increase-Business Personal Property
001	835 N 7TH ST CAMDEN NJ 08102-1844	\$ 477,000	\$ 50,000	25%

* As of the effective date of this policy, the Limit of Insurance as shown includes any increase in the limit due to Inflation Coverage.

SECTION I - INFLATION COVERAGE INDEX(ES)

Cov A - Inflation Coverage Index: 244.4
 Cov B - Consumer Price Index: 303.4

MAY 30 2023

SECTION I - DEDUCTIBLES

Basic Deductible \$2,500

Special Deductibles:

Money and Securities \$250 Employee Dishonesty \$250
 Equipment Breakdown \$2,500

Other deductibles may apply - refer to policy.

Prepared
 MAY 30 2023
 CMP-4000

© Copyright, State Farm Mutual Automobile Insurance Company, 2008
 Includes copyrighted material of Insurance Services Office, Inc., with its permission.

DECLARATIONS (CONTINUED)

Food Shop Policy for HASSAN, RYAD A
 Policy Number 90-CW-K462-6

**SECTION I - EXTENSIONS OF COVERAGE - LIMIT OF INSURANCE - EACH DESCRIBED PREMISES**

The coverages and corresponding limits shown below apply separately to each described premises shown in these Declarations, unless indicated by "See Schedule." If a coverage does not have a corresponding limit shown below, but has "Included" indicated, please refer to that policy provision for an explanation of that coverage.

ST.2
0221-2001

COVERAGE	LIMIT OF INSURANCE
Accounts Receivable	
On Premises	\$10,000
Off Premises	\$5,000
Arson Reward	\$5,000
Back-Up Of Sewer Or Drain	\$15,000
Collapse	Included
Damage To Non-Owned Buildings From Theft, Burglary Or Robbery	Coverage B Limit
Debris Removal	25% of covered loss
Equipment Breakdown	Included
Fire Department Service Charge	\$5,000
Fire Extinguisher Systems Recharge Expense	\$5,000
Food Contamination	
Additional Advertising Expenses	\$3,000
Per Occurrence	\$10,000
Forgery Or Alteration	\$10,000
Glass Expenses	Included
Increased Cost Of Construction And Demolition Costs (applies only when buildings are insured on a replacement cost basis)	10%
Money And Securities (Off Premises)	\$5,000
Money And Securities (On Premises)	\$10,000
Money Orders And Counterfeit Money	\$1,000

Prepared
 MAY 30 2023
 CMP-4000

© Copyright, State Farm Mutual Automobile Insurance Company, 2008
 Includes copyrighted material of Insurance Services Office, Inc., with its permission.

Continued on Reverse Side of Page

Page 3 of 6

DECLARATIONS (CONTINUED)

Food Shop Policy for HASSAN, RYAD A
Policy Number 90-CW-K462-6

Newly Acquired Business Personal Property (applies only if this policy provides Coverage B - Business Personal Property)	\$100,000
Newly Acquired Or Constructed Buildings (applies only if this policy provides Coverage A - Buildings)	\$250,000
Ordinance Or Law - Equipment Coverage	Included
Outdoor Property	\$5,000
Personal Effects (applies only to those premises provided Coverage B - Business Personal Property)	\$2,500
Personal Property Off Premises	\$15,000
Pollutant Clean Up And Removal	\$10,000
Preservation Of Property	30 Days
Property Of Others (applies only to those premises provided Coverage B - Business Personal Property)	\$2,500
Signs	\$10,000
Spoilage (applies only to those premises provided Coverage B - Business Personal Property)	
Expediting Expenses	\$1,000
On Premises	\$15,000
Off Premises	\$5,000
Valuable Papers And Records	
On Premises	\$10,000
Off Premises	\$5,000
Water Damage, Other Liquids, Powder Or Molten Material Damage	Included

MAY 30 2023

SECTION I - EXTENSIONS OF COVERAGE - LIMIT OF INSURANCE - PER POLICY

The coverages and corresponding limits shown below are the most we will pay regardless of the number of described premises shown in these Declarations.

COVERAGE	LIMIT OF INSURANCE
Dependent Property - Loss Of Income	\$5,000

Prepared
MAY 30 2023
CMP-4000

© Copyright, State Farm Mutual Automobile Insurance Company, 2008
Includes copyrighted material of Insurance Services Office, Inc., with its permission.

DECLARATIONS (CONTINUED)

Food Shop Policy for HASSAN, RYAD A
Policy Number 90-CW-K462-6



Employee Dishonesty	\$10,000
Utility Interruption - Loss Of Income	\$10,000
Loss Of Income And Extra Expense	Actual Loss Sustained - 12 Months

ST-2
0321-2001

SECTION II - LIABILITY

COVERAGE	LIMIT OF INSURANCE
Coverage L - Business Liability	\$1,000,000
Coverage M - Medical Expenses (Any One Person)	\$5,000
Damage To Premises Rented To You	\$300,000
AGGREGATE LIMITS	LIMIT OF INSURANCE
Products/Completed Operations Aggregate	\$2,000,000

Each paid claim for Liability Coverage reduces the amount of insurance we provide during the applicable annual period. Please refer to Section II - Liability in the Coverage Form and any attached endorsements.

Your policy consists of these Declarations, the **BUSINESSOWNERS COVERAGE FORM** shown below, and any other forms and endorsements that apply, including those shown below as well as those issued subsequent to the issuance of this policy.

FORMS AND ENDORSEMENTS

CMP-4100	Businessowners Coverage Form
CMP-4561.4	Policy Endorsement
CMP-4705.2	Loss of Income & Extra Expnse
CMP-4230.1	Amendatory Endorsement
CMP-4710	Employee Dishonesty
CMP-4775	Spoilage Coverage
FE-6999.3	Terrorism Insurance Cov Notice
CMP-4806	Fungus Limited Cov \$10,000
FE-3650	Actual Cash Value Endorsement

Prepared
MAY 30 2023
CMP-4000

© Copyright, State Farm Mutual Automobile Insurance Company, 2008
Includes copyrighted material of Insurance Services Office, Inc., with its permission.

Continued on Reverse Side of Page

DECLARATIONS (CONTINUED)

Food Shop Policy for HASSAN, RYAD A
Policy Number 90-CW-K462-6

CMP-4702.1	Food Contamination
CMP-4706	Back-Up of Sewer or Drain
CMP-4704.1	Dependent Prop Loss of Income
CMP-4709	Money and Securities
CMP-4703.1	Utility Interruption Loss Incrn
FD-6007	Inland Marine Attach Dec

This policy is issued by the State Farm Fire and Casualty Company.

Participating Policy

You are entitled to participate in a distribution of the earnings of the company as determined by our Board of Directors in accordance with the Company's Articles of Incorporation, as amended.

In Witness Whereof, the State Farm Fire and Casualty Company has caused this policy to be signed by its President and Secretary at Bloomington, Illinois.

Lynne M. Youell
Secretary

Michael F. Lynn
President

MAY 30 2023

Prepared
MAY 30 2023
CMP-4000

© Copyright, State Farm Mutual Automobile Insurance Company, 2008
Includes copyrighted material of Insurance Services Office, Inc., with its permission.

013143 290
N

STATE FARM FIRE AND CASUALTY COMPANY
A STOCK COMPANY WITH HOME OFFICES IN BLOOMINGTON, ILLINOIS

INLAND MARINE ATTACHING DECLARATIONS

Po Box 2915
Bloomington IL 61702-2915

Named Insured

M-17-09F1-FA3F F Z

HASSAN, RYAD A
DBA FRITZ'S FOOD MARKET
835 N 7TH ST
CAMDEN NJ 08102-1844

Policy Number	90-CW-K462-6	
Policy Period	Effective Date	Expiration Date
12 Months	MAY 12 2023	MAY 12 2024
The policy period begins and ends at 12:01 am standard time at the premises location.		



ST 2
0421-2001

ATTACHING INLAND MARINE

Automatic Renewal - If the policy period is shown as **12 months**, this policy will be renewed automatically subject to the premiums, rules and forms in effect for each succeeding policy period. If this policy is terminated, we will give you and the Mortgagee/Lienholder written notice in compliance with the policy provisions or as required by law.

Annual Policy Premium Included

The above Premium Amount is included in the Policy Premium shown on the Declarations.

Your policy consists of these Declarations, the **INLAND MARINE CONDITIONS** shown below, and any other forms and endorsements that apply, including those shown below as well as those issued subsequent to the issuance of this policy.

Forms, Options, and Endorsements

FE-8743.1 Inland Marine Computer Prop
FE-8739 Inland Marine Conditions

See Reverse for Schedule Page with Limits

Prepared
MAY 30 2023
FD-6007

© Copyright, State Farm Mutual Automobile Insurance Company, 2008
Includes copyrighted material of Insurance Services Office, Inc., with its permission.

013144

530-866 a.2 05-31-2011 (013232c)

ATTACHING INLAND MARINE SCHEDULE PAGE

ATTACHING INLAND MARINE

ENDORSEMENT NUMBER	COVERAGE	LIMIT OF INSURANCE	DEDUCTIBLE AMOUNT	ANNUAL PREMIUM
FE-8743.1	Inland Marine Computer Prop	\$ 25,000	\$ 500	Included
	Loss of Income and Extra Expense	\$ 25,000		Included

MAY 30 2023

OTHER LIMITS AND EXCLUSIONS MAY APPLY - REFER TO YOUR POLICY

Prepared
MAY 30 2023
FD-6007

© Copyright, State Farm Mutual Automobile Insurance Company, 2008
Includes copyrighted material of Insurance Services Office, Inc., with its permission.



DEPARTMENT OF PLANNING & DEVELOPMENT
CITY OF CAMDEN
NEW JERSEY

1/22/20
DR. EDWARD C. WILLIAMS, PP, AICP, CSI
Division of Planning & Zoning
TEL: (856) 757-7214

FRANCISCO "FRANK" MORAN
MAYOR

January 21, 2020

HASON RIYAD
835 NORTH 7TH STREET
CAMDEN, NEW JERSEY 08102

ZONING PERMIT DENIAL

RE: 835 NORTH 7TH STREET CAMDEN, NJ
APPLICATION DATE: 1/13/2020

BLOCK: 760 LOT: 101
ZONE DISTRICT: R-2

DEAR SIR/MADAM:

YOUR APPLICATION FOR A ZONING PERMIT TO ALLOW: GROCERY STORE - ENCLOSED PORCH EXTENSION
HAS BEEN DENIED FOR THE FOLLOWING:

1. PORCH EXTENSION ENCROACHES ON THE SIDEWALK - (C) BULK VARIANCE FOR LESS THAN 0' LOT LINE.
2. CITY COUNCIL APPROVAL IS NEEDED.

YOU MAY APPEAL THIS DECISION WITHIN 20 DAYS OF THIS DENIAL, BY MAKING THE NECESSARY APPLICATION TO THE DIVISION OF PLANNING, CITY HALL - ROOM 224, FOR A VARIANCE OR A SPECIAL EXCEPTION IN THIS MATTER. ENCLOSED FOR YOUR CONVENIENCE IS SAID APPEAL FORM.

IF YOU HAVE QUESTIONS, DO NOT HESITATE TO CONTACT THIS OFFICE.

SINCERELY,

DR. EDWARD C. WILLIAMS, PP., AICP, CSI
DIRECTOR/ZONING OFFICER

ENCLOSURE

Cc: Building Bureau



DEPARTMENT OF PLANNING & DEVELOPMENT
CITY OF CAMDEN
NEW JERSEY

DR. EDWARD C. WILLIAMS, PP, AICP, CSI
Division of Planning & Zoning
TEL.: (856) 757-7214

FRANCISCO "FRANK" MORAN
MAYOR

January 21, 2020

HASON RIYAD
835 NORTH 7TH STREET
CAMDEN, NEW JERSEY 08102

ZONING PERMIT DENIAL

RE: 835 NORTH 7TH STREET CAMDEN, NJ
APPLICATION DATE: 1/13/2020

BLOCK: 760 LOT: 101
ZONE DISTRICT: R-2

DEAR SIR/MADAM:

YOUR APPLICATION FOR A ZONING PERMIT TO ALLOW: GROCERY STORE - ENCLOSED PORCH EXTENSION
HAS BEEN DENIED FOR THE FOLLOWING:

1. PORCH EXTENSION ENCROACHES ON THE SIDEWALK – (C) BULK VARIANCE FOR LESS THAN 0' LOT LINE.
2. CITY COUNCIL APPROVAL IS NEEDED.

YOU MAY APPEAL THIS DECISION WITHIN 20 DAYS OF THIS DENIAL, BY MAKING THE NECESSARY APPLICATION TO THE DIVISION OF PLANNING, CITY HALL – ROOM 224, FOR A VARIANCE OR A SPECIAL EXCEPTION IN THIS MATTER. ENCLOSED FOR YOUR CONVENIENCE IS SAID APPEAL FORM.

IF YOU HAVE QUESTIONS, DO NOT HESITATE TO CONTACT THIS OFFICE.

SINCERELY,



DR. EDWARD C. WILLIAMS, PP., AICP, CSI
DIRECTOR/ZONING OFFICER

ENCLOSURE

Cc: Building Bureau

Submission: 1/13/20
Completion: _____

Location: 835 No 7th Street
Zone District: R-2

Block 760 Lot 101
Submission: Zoning R-2 Sign _____

I FILING INFORMATION

- A. Completed Application (1)
- B. Ownership Information (1)
- C. Sketch: Floor Plan (1)
 - Sign Drawing (1)
 - Property Survey (1)
- D. Fees: Zoning 87.30 (1)
 - Sign (1)
- E. Tax Cert: Owe Ok (1)

USE: Grocery Store
Enclosed Porch
SIGN: _____

II ZONING INFORMATION

	REQUIRED	PROPOSED
A. Lot Area	_____	_____
B. Lot width	_____	_____
C. Lot Frontage	_____	_____
D. Building Height	_____	_____
E. Parking	_____	_____
F. Sign Dimensions	_____	_____
G. Fence Height	_____	_____

III YARD REQUIREMENTS

	REQUIRED	PROPOSED
A. Front Setback	_____	_____
B. Rear Setback	_____	_____
C. Side Setback	_____	_____

IV Other Approvals Needed

- A. Planning Board _____
- B. Zoning Board ✓
- C. County Planning _____
- D. City Council ✓
- E. A R C _____
- F. H R C _____

(FOR OFFICE USE ONLY)

ZONING: Approved ✓ SIGN: Approved _____
Denied ✓ Denied _____

Reasons for Denial: 1. Porch extension encroaches on
setback, (C) Bulk Volume Per less than
0' lot line. 2. City Council Appeal is on

CITY OF CAMDEN
DIVISION OF PLANNING
CITY HALL – ROOM 224
PO BOX 95120
CAMDEN, NEW JERSEY 08101-5120
(856) 757-7214

INSTRUCTIONS FOR ZONING/SIGN PERMIT APPLICATION

ALL APPLICANTS WHO NEED A ZONING/SIGN PERMIT MUST SUBMIT THE FOLLOWING:

1. Completed Zoning AND/OR Sign Application
2. Proof of ownership (deed, tax bill, or lease) (Leases must be notarized)
3. A detail floor plan of proposed use, conversion of single family dwelling shall have measurement of all habitable space. Accurate drawing of a proposed sign including dimensions and illustration signed by sign supplier. **Any addition or accessory uses or fences must have a Plot Plan and/or Survey.** Additions/Fences must be presented on a Plot Plan/Survey with rear and side set back. You can obtain a Plot Plan from the Engineering Dept. located in City Hall, Room 325.
*(copy of all/any plans must accompany application.

4. Completed attached Tax Certification (City of Camden Tax Office Room 117 1st floor plus Water/Sewer PNC Bank located Broadway & Market St.)

5. Application fee:
(non-refundable)

Single Family Dwelling	\$ 69.56
Two-Family Dwelling	\$ 139.13
Three-Family Dwelling	\$ 215.51
Or More	
Rooming House	\$ 259.16
Boarding House	\$ 259.16
Commercial Use	\$ 87.30
Industrial Warehousing & Manufacturing Use	\$ 139.87
Institutional Use	\$ 69.56
Advertising Billboards	\$ 395.56
Sign Application	\$ 79.11
Rezoning Application	\$ 345.09

Money Order or Check payable to the City of Camden

PLEASE RETURN COMPLETED APPLICATIONS TO THE ABOVE ADDRESS. **INCOMPLETE APPLICATIONS SHALL NOT BE PROCESS. ANY APPLICATION WHICH REMAINS INCOMPLETE FOR MORE THAN 10 BUSINESS DAYS WILL BE DISCARDED.** FALSIFICATION IN ANY FORM SHALL SUBJECT APPLICANT TO A FINE OR MUNICIPAL COURT.

No construction, erection, alteration, repair, remodeling, conversion, renovation or demolition of any building or structure shall begin prior to Zoning approval. Other municipal agency approvals maybe required.

DO NOT REMOVE OR DISCARD ANY PART OF THIS APPLICATION

I. GENERAL

Today's Date: 1/12/2020

Applicant: Riyad Hason Telephone: 856 203 3931

Applicant's Address: 935 N 7th St - Camden NJ 08102

Applicant Interest: (please check one) owner tenant agent/owner

SUBMITTING FOR: Zoning Permit Sign Permit

1. Name and Address of property OWNER if different from that of applicant:

DASUN

2. Address and Block and Lot number for which zoning/sign permit is desired:

935 N 7th St Camden Block: 760 Lot: 101

3.

Zone District:	R1	R2	R3	C1	C2	C3	C4	LH	LI2	GI1	GI2
(please circle)	US	PR1	OL1	TOD	MW1	MW2	MS	CV2	CC		

4. Historic District: _____

5. What is the property/land PRESENTLY being used *entirely* as:

Commercial mix used

6. Is the structure presently vacant? No If so how long? _____

7. How many stories/floors does the building have? 2 Is there a basement/cellar? Yes

II. ZONING

1. What is being proposed?

New Construction _____ Addition _____ Fence _____ (ht _____) Installation _____

New Business _____ Conversion _____ Other (explain: _____)

2. Describe in detail the use & activities **PROPOSED** (attached separate sheet if necessary):

porch closed out wonds and
door install

3. Are there other activities existing within the same property? N/A (please describe)

4. Dimensions of Principal Building and/or structure 65 f 16

5. Dimensions of All Accessory Building and/or structure _____

6. Are any of the activities conducted in the principal building existing as a nonconforming use?

No _____ Yes _____ (please explain) _____

7. To the applicant's knowledge, has there been any prior applications made to the Zoning Board of Adjustment or the Planning Board?

No _____ Yes _____ (please explain) _____

THIS APPLICANT CERTIFIES THAT THE ABOVE INFORMATION HAS BEEN COMPLETED TO THE BEST OF HIS/HER KNOWLEDGE.

1-11-2020
(Date)

Rykel Hanson
(Signature of Applicant)

(Name of Corporation or Association)

DO NOT REMOVE OR DISCARD ANY PART OF THIS APPLICATION

III. SIGN

1. Type Sign: Awning / Billboard / Freestanding / Hanging / Mounted / Off Site / Window
(please circle)

Other (describe): _____ Alteration of an existing sign _____
(attach photo & describe) _____

2. Are there any existing signs? Yes (if yes, please attach photos)

3. How many signs are proposed? _____

4. Will sign(s) be illuminated? Yes _____ No _____

5. Dimension: _____ X _____ = _____ sq ft.

6. Distance between ground and the lowest part of sign _____ ft.

7. Distance between ground and highest part of the sign _____ ft.

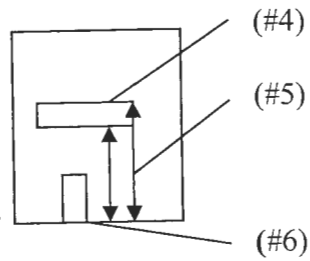

8. Material of Sign: _____

9. Color(s) on sign(s): _____

10. Illustration/Wording: _____

=====

THIS APPLICANT CERTIFIES THAT THE ABOVE INFORMATION HAS BEEN COMPLETED TO THE BEST OF HIS/HER KNOWLEDGE AND FURTHER UNDERSTANDS THAT IF THE SIGN EXCEEDS THE MAXIMUM REQUIREMENT A VARIANCE THROUGH THE PLANNING BOARD OF THE CITY OF CAMDEN MUST BE REQUESTED.

(Date)

(Signature of Applicant)

(Name of Corporation or Association)

DO NOT REMOVE OR DISCARD ANY PART OF THIS APPLICATION

IV. ASSESSMENT CERTIFICATION

Section A: Applicant shall complete

SECTION A	<u>OWNER</u>
Name of OWNER of Property <u>Rixed Hoson</u>	
Address: <u>835 N 7th St Camden NJ</u>	
SEARCH Address: <u>DSAm</u>	
Block: <u>760</u>	Lot: <u>101</u> Account: <u>7-0467592-5</u>

Section B: Applicant shall take this form to the City of Camden Tax Office, Room 117 (1st floor) for completion to indicate whether taxes are paid up to date. Applicant must also go to the PNC Bank (Broadway & Market St) for water and sewer to make sure water /sewer is paid up to date. Upon completion, this form shall be submitted with original application. NO APPLICATIONS WILL BE ACCEPTED – if any money is owed for Taxes or Water/Sewer, no permit can be issued until accounts are paid in full-proof of payment must be brought back before turning application in.

Section C: TAX OFFICE & PNC BANK
 An application for Zoning/Sign permit has been submitted to the Division of Planning. Please check your records to be certain that the account is current

I HEREBY CERTIFY THAT THE PROPERTY ASSESSMENT ARE:
****MORTGAGE LETTERS ON LETTERHEAD WILL BE ACCEPTED FOR SALE/RESALE PROPERTIES ONLY****

Account Type	Qtr.	Due date	Amount Owed	Other
(Taxes/W&S/Other)	<u>TH</u>	<u>11/1</u>	<u>705.74</u>	<u>PR 1-10-2020</u>
(Taxes/W&S/Other)	<u>Not</u>	<u>Billing</u>	<u>AH</u>	<u>1-10-2020</u>
(Taxes/W&S/Other)	_____	_____	_____	_____
(Taxes/W&S/Other)	_____	_____	_____	_____

COMMENTS: _____

DATED: _____ **PREPARED BY:** _____

WESTERN UNION

MONEY ORDER

THIS DOCUMENT CONTAINS A TIME SENSITIVE MARK - HOLD UP TO LIGHT TO VIEW

RITE AID

(ISSUING AGENT)

47-046768246

A 278119 D 011320
T 0917 52
470467682462 L 00523

\$ 87.30

PAY EXACTLY
PAY TO THE
ORDER OF

EIGHTY SEVEN DOLLARS AND 30 CENTS

Handwritten signature

PAYMENT FOR ACCT. #

PURCHASER'S ADDRESS

Handwritten signature

PURCHASER'S SIGNATURE
Required by statute for all money orders. Signatures are required on the reverse side.

⑆102100400⑆ 40470467682462⑆

~~217 2021~~



Enclosed Porch

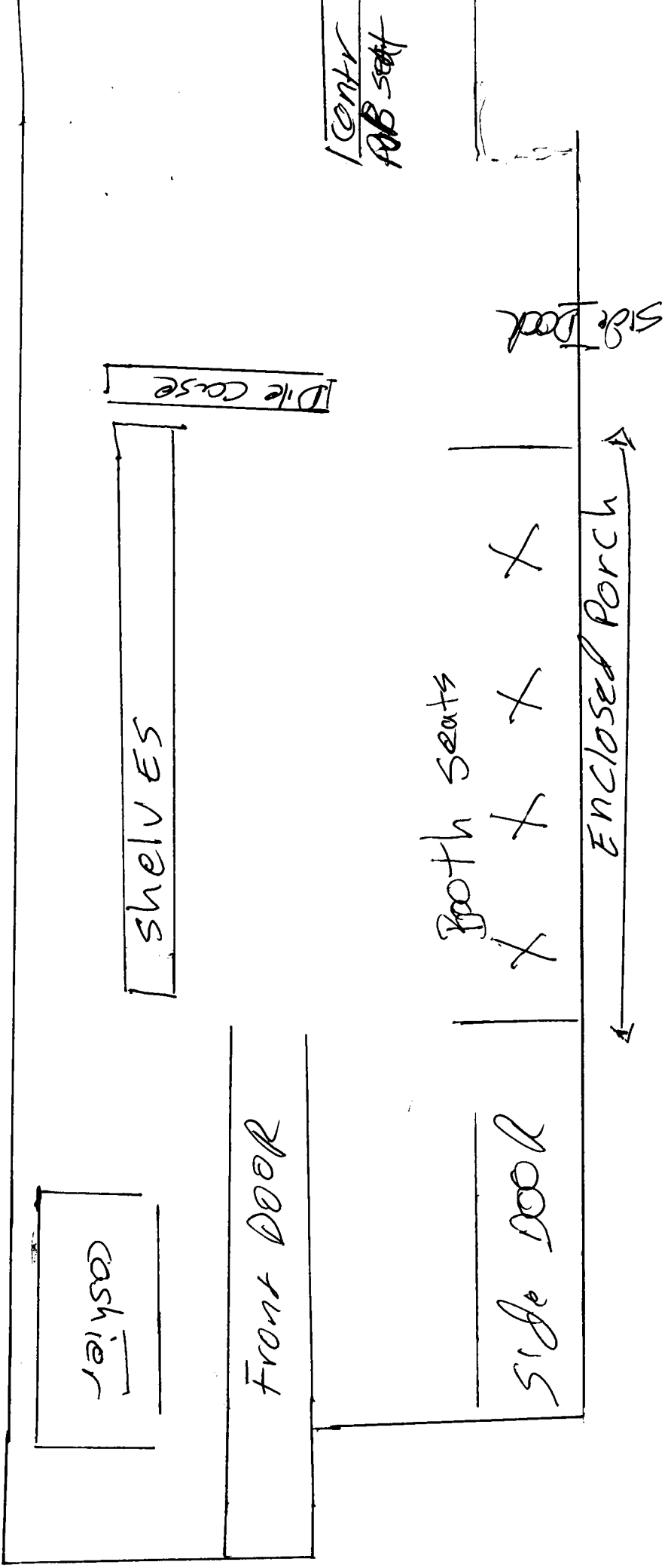

Add Edit Close Delete Previous Next Detail Letter Help

Block: 760
 Lot: 101

Notes Exist

Qualifier:

Owner: RIYAD, HASAN A

Prop Loc: 835 NO 7TH ST

Account Id: 00014576

Tax Bill

PTR Form

Restricted Edit

Year	Qtr	Type	Billed	Additional	Billing	Deductions	Principal Balance	Balance	Interest	All Charges	Add/Omit	Notes
2019	4		512.64				512.64	17.69		530.33		
2019	3		512.65				512.65	40.76		553.41		
2019	2		518.08					.00		.00		
2019	1		518.10					.00		.00		
2019		Total	2,061.47					1,025.29		58.45		1,083.74
2018	4		519.81					.00		.00		

Other Delinquent Balances: .00 Interest Date: 01/10/20

Interest Date

Interest Detail

Other APR2 Threshold Amt: 2,964.36 Per Diem: 5126 Last Payment Date: 08/28/2018

TOTAL TAX BALANCE DUE

Principal: 1,025.29 Penalty: .00

Misc. Charges: .00 Interest: 58.45 Total: 1,083.74

* Indicates Adjusted Billing in a Tax Quarter.

RESOLUTION # 36

Resolution authorizing a contract to (TBD) for event coordinator
(by title)

RESOLUTION

**NOT available at time of print on
Friday, March 01, 2024.**



CITY OF CAMDEN — CITY COUNCIL ACTION REQUEST FORM



COUNCIL MEETING DATE: 03/12/2024

TO: City Council
FROM: Dr. Edward C. Williams, PP, AICP, CSI, AHP, CZO, CPZBS

TITLE OF ORDINANCE/RESOLUTION: RESOLUTION AUTHORIZING A CONTRACT TO [TBD] FOR EVENT COORDINATOR

Point of Contact:	Lateefah Chandler	Admin-Purchasing	856-757-7475	lachandl@ci.camden.nj.us
	Name	Department-Division-Bureau	Phone	Email

ENDORSEMENTS

	Recommend Approval (Y/N)	Signature	Date	Comments
Responsible Department Director	Y		2-22-24	
Supporting Department Director (if necessary)				
Grants Management				
Qualified Purchasing Agent	Y		2/21/2024	
Director of Finance				

Approved by:
Business Administrator

Signature

Date

Attachments (list and attach all available):

1. Waiver Request Form Attached for State DCA/DLGS Approval - (If applicable)¹
2. Certification of Funds²
3. Addition supporting documents.

"Walk-on" note: All walk-on legislation must be pre-approved by the Business Administrator. The Department Director and Contact Person are jointly responsible for delivering all necessary documents to the City Clerk for distribution at the Council Meeting.

Received by:

City Attorney

Signature

Date

¹ For Example: Form "A" - Request for approval of Employees Requiring Advice and Consent of Governing Body, Form "D" - Contract Request, Form "E" - Creation/Extension of Services, Form "G" - Grant Approval, Form "H" - Bond Ordinance or Contract Request, Form "I", "Best Price Insurance Contracting" Model Ordinance

² Mandatory for any financial commitment to the City or expenditure of City Funds.

EXECUTIVE SUMMARY

TITLE OF ORDINANCE/RESOLUTION: RESOLUTION AUTHORIZING A CONTRACT TO [TBD] FOR EVENT COORDINATOR

FACTS/BACKGROUND: (Executive level details. Short concise bullets)

- Bid opens on February 29, 2024 for event coordinator.
- An event coordinator is needed for the City's first UEZ Business Expo slated from May - June.
- City intends to host 4 events to showcase UEZ business in various wards.

AMOUNT OF PROPOSED CONTRACT or TOTAL COST OF PROPOSAL: TBD

APPROPRIATION NUMBER: TBD

PROCUREMENT: BID #24-02

IMPACT STATEMENT:

- N/A

SUBJECT MATTER EXPERTS/ADVOCATES:

- N/A

COORDINATION:

- N/A

Prepared by: LATEEAH CHANDLER

856-757-7159

Name

Phone/Email

**STATE OF NEW JERSEY
DEPARTMENT OF COMMUNITY AFFAIRS
DIVISION OF LOCAL GOVERNMENT SERVICES
CONTRACT REQUEST FORM**

This form must be filled out in its entirety and is intended to provide the Division with appropriate information to determine whether to approve a new or extended service. Please provide any additional information you believe will help the Division make an informed decision.

Municipality	CITY OF CAMDEN
--------------	----------------

Professional Service or EUS Type	N/A
Name of Vendor	TBD
Purpose or Need for service:	EVENT COORDINATOR
Contract Award Amount	TBD
Term of Contract	~6 MONTHS
Temporary or Seasonal	N/A
Grant Funded (attach appropriate documentation allowing for service through grant funds)	N/A
Please explain the procurement process (i.e. bids, RFQ, competitive contracting, etc.)	BID 24-02
Were other proposals received? If so, please attach the names and amounts for each proposal received?	TBD

Please attach the RFP, evaluation memoranda or evaluation forms used to evaluate the vendors and a list of all bidders and the bid amounts associated with each bidder.

If the lowest bidder was not selected, please have the appropriate personnel sign the certification on page 2.

Mayor's Signature*

Date _____

Business Administrator/Manager Signature

Date _____

*For direct appointments of the Governing Body, Council President or at the discretion of the Director, the most senior member of the Governing Body may sign the waiver in lieu of the Mayor.

The Financial Officer affirms that there is adequate funding available for this action.

Financial Officer Signature

I certify that the vendor selected is in compliance with the adopted Pay to Play Ordinance and that the vendor was notified of any restrictions with respect to campaign contributions.

Certifying Officer Date _____

For LGS use only:

Approved Denied

Director or Designee, Date _____
Division of Local Government Services

Number Assigned _____

R-37

DSB:dh
03-12-24

RESOLUTION AUTHORIZING THE AMENDMENT OF THE USEPA BROWNFIELDS
CLEAN-UP REVOLVING LOAN FUND SUB-GRANT AGREEMENT BETWEEN THE
CITY OF CAMDEN AND THE CITY OF CAMDEN REDEVELOPMENT AGENCY
RESPECTING THE RELIABLE TIRE SITE

WHEREAS, the City of Camden (the "City") has entered into an US EPA Brownfields Clean-up Revolving Loan Fund Sub-Grant Agreement with the City of Camden Redevelopment Agency which granted the City \$274,203 to remediate the Reliable Tire Site located at 1115 Chestnut St.; and

WHEREAS, the cost to remediate the site will exceed the original amount of the sub-grant; and

WHEREAS, the parties desire to amend the Sub-Grant Agreement to increase the amount of the sub-grant from \$274,203 to \$500,000, now therefore

BE IT RESOLVED, by the governing body of the City of Camden that the proper officials are hereby authorized to amend the above mentioned grant agreement to increase the amount of the sub-grant from \$274,203 to \$500,000.

BE IT FURTHER RESOLVED, that pursuant to the N.J.S.A. 52:27BBB-23, a true copy of this Resolution shall be forwarded to the Chief Operating Officer, who shall have ten (10) days from the receipt thereof to approve or veto this Resolution. Notice of approval or veto shall be filed in the office of the Municipal Clerk.

Dated: March 12, 2024

The above has been reviewed
and approved as to form.

DANIEL S. BLACKBURN
City Attorney

ANGEL FUENTES
President, City Council

ATTEST: _____
LUIS PASTORIZA
Municipal Clerk



CITY OF CAMDEN — CITY COUNCIL ACTION REQUEST FORM

COUNCIL MEETING DATE: MARCH 14, 2024

TO: City Council
FROM: Tim Cunningham, BA
Dr. Edward C. Williams, PP, AICP, CSI, AHP, CZO

TITLE OF ORDINANCE/RESOLUTION:

Resolution Amending Resolution MC-23:9080 Between the City of Camden and the Camden Redevelopment Agency to Increase a Sub-Grant Award from U.S. Environmental Protection Agency Brownfield Revolving Loan Fund From \$274,203.00 to \$500,000.00 for the Environmental Remediation of former Reliable Tire Site (Block 1302, Lot 1)

Point of Contact:	Olivette Simpson	Department of Development & Planning		
	Name	Department-Division-Bureau	Phone	Email

ENDORSEMENTS

	Recommend Approval (Y/N)	Signature	Date	Comments
Responsible Department Director				
Supporting Department Director (if necessary)				
Director of Grants Management				
Qualified Purchasing Agent				
Director of Finance				

Approved by:
Business Administrator

_____	Signature	Date
-------	-----------	------

Attachments (list and attach all available):

1. Waiver Request Form Attached for State DCA/DLGS Approval - (If applicable)¹
2. Form of Shared Services Agreement

"Walk-on" note: All walk-on legislation must be pre-approved by the Business Administrator. The Department Director and Contact Person are jointly responsible for delivering all necessary documents to the City Clerk for distribution at the Council Meeting.

Received by:
City Attorney

_____	Signature	Date
		1 Mar 24

¹ For Example: Form "A" - Request for approval of Employees Requiring Advice and Consent of Governing Body, Form "D" - Contract Request, Form "E" - Creation/Extension of Services, Form "G" - Grant Approval, Form "H" - Bond Ordinance or Contract Request, Form "I", "Best Price Insurance Contracting" Model Ordinance

EXECUTIVE SUMMARY

TITLE OF ORDINANCE/RESOLUTION

Resolution Amending Resolution MC-23:9080 Between the City of Camden and the Camden Redevelopment Agency to Increase a Sub-Grant Award from U.S. Environmental Protection Agency Brownfield Revolving Loan Fund From \$274,203.00 to \$500,000.00 for the Environmental Remediation of former Reliable Tire Site (Block 1302, Lot 1)

FACTS/BACKGROUND: (Executive level details. Short concise bullets)

- The Reliable Tire Site, owned by the City of Camden and designated as Block 1320, Lot 1 on the City Tax Map is located at 1115 Chestnut Street, Camden, New Jersey (the Property Site). The Project Site is approximately two acres in size and zoned per the Gateway Redevelopment Plan as Office / Light Industrial. The City acquired the Project Site in a 2018 tax foreclosure.
- CRA, as part of its redevelopment responsibilities, administers the City of Camden Brownfield Program, including the brownfield planning activities, applying for and managing grants for brownfield investigation and remediation.
- A Shared Services Agreement (MC-23:9079) between the City and CRA to manage the grant funds and remediation of the Property Site.
- The City by Resolution MC-23:9080 authorized the execution of a Sub-grant Agreement between the City and the CRA for funds from the U.S. Environmental Protection Agency Brownfield Revolving Loan Fund for \$274,203.00 for the clean-up of the Property Site.
- Site Conditions: The Property Site contains five underground storage tanks required by NJ DEP be removed from the Site as well as three contaminated soil hot spots be excavated and soil disposed of to an appropriate off-site facility and the site backfilled with clean soil material.
- **The lowest responsible bid received for remediation of the site is higher than estimated. As a result, an increase in the sub-grant award to the City from \$274,203 to \$500,000 is required.**

AMOUNT OF PROPOSED CONTRACT or TOTAL COST OF PROPOSAL: \$500,000.00

IMPACT STATEMENT:

- The City, through tax foreclosure is the owner of the Reliable Tire Site. The Project Site has the potential after remediation to serve as a catalyst for redevelopment of the immediate area and assist in meeting the demand for clean commercial/industrial land for reuse. If the request is not approved, remediation of the Project Site will not move forward and future remedial activities will likely be the responsibility of the City.

SUBJECT MATTER EXPERTS/ADVOCATES:

- Olivette Simpson, CRA
 - Attendance

COORDINATION: CRA, Brownfield Redevelopment Solutions, Inc., environmental consultant

Prepared by: Olivette Simpson, CRA Ext. 3540 olsimpo@ci.camden.nj.us

Name

Phone/Email

**STATE OF NEW JERSEY
DEPARTMENT OF COMMUNITY AFFAIRS
DIVISION OF LOCAL GOVERNMENT SERVICES
CONTRACT REQUEST FORM**

This form must be filled out in its entirety and is intended to provide the Division with appropriate information to determine whether to approve a new or extended service. Please provide any additional information you believe will help the Division make an informed decision.

Municipality	CITY OF CAMDEN
Professional Service or EUS Type	CRA's U.S. Environmental Protection Agency Brownfield Revolving Loan Fund Sub-Grant Agreement-Amendment #1
Name of Vendor	CAMDEN REDEVELOPMENT AGENCY ("CRA")
Purpose or Need for service:	Resolution Amending Resolution MC-23:9080 Between the City of Camden and the Camden Redevelopment Agency to Increase a Sub-Grant Award from U.S. Environmental Protection Agency Brownfield Revolving Loan Fund From \$274,203.00 to \$500,000.00 for the Environmental Remediation of former Reliable Tire Site (Block 1302, Lot 1)
Contract Award Amount	Zero
Term of Contract	2 years
Temporary or Seasonal	
Grant Funded (attach appropriate documentation allowing for service through grant funds)	
Please explain the procurement process (i.e. bids, RFQ, competitive contracting, etc.)	
Were other proposals received? If so, please attach the names and amounts for each proposal received?	

Please attach the RFP, evaluation memoranda or evaluation forms used to evaluate the vendors and a list of all bidders and the bid amounts associated with each bidder.

If the lowest bidder was not selected, please have the appropriate personnel sign the certification on page 2.

Mayor's Signature*

Date

Business Administrator/Manager Signature

Date

*For direct appointments of the Governing Body, Council President or at the discretion of the Director, the most senior member of the Governing Body may sign the waiver in lieu of the Mayor.

The Chief Financial Officer affirms that there is adequate funding available for this personnel action.
_____ Funding Source for this action

Chief Financial Officer Signature

I certify that the vendor selected is in compliance with the adopted Pay to Play Ordinance and that the vendor was notified of any restrictions with respect to campaign contributions.

Certifying Officer

Date _____

For LGS use only:

Approved Denied

Date _____

Director or Designee,
Division of Local Government Services

Number Assigned _____

STATE OF NEW JERSEY
DEPARTMENT OF COMMUNITY AFFAIRS
DIVISION OF LOCAL GOVERNMENT SERVICES
GRANT APPROVAL FORM

This form must be filled out in its entirety and is intended to provide the Division with appropriate information to determine whether to approve a new or extended service. Please provide any additional information you believe will help the Division make an informed decision.

PLEASE EXPLAIN THE JUSTIFICATION FOR THE GRANT. PLEASE FULLY EXPLAIN COST ASSOCIATED WITH THE AWARD OF THE GRANT AS WELL AS ANY MATCHING FUNDS OR EMPLOYMENT OBLIGATIONS AS A TERM OF THE GRANT. PLEASE EXPLAIN THE BENEFITS OF THE GRANT OF THE MUNICIPALITY AND THE RESIDENTS. ATTACH THE GRANT APPLICATION AND GRANT AWARD LETTER.

Resolution Amending Resolution 04-12-23C to Authorize an Increase in a Sub-grant from \$274,203.00 to \$500,000.00 to the City of Camden from the U.S. Environmental Protection Agency Brownfields Revolving Loan Fund for the Environmental Remediation of Block 1302, Lot 1 of the City of Camden Tax Map

- In 2013, CRA, with a grant from the U.S. Environmental Protection Agency ("EPA") established a Brownfields Revolving Loan Fund ("RLF") to make loans and Sub-grants to fund environmental cleanup of brownfield sites in Camden.
- The EPA RLF program guidelines allow CRA to make Sub-grants to non-profits and other units of local government for eligible projects and uses.
- The Reliable Tire Site (Block 1302, Lot 1) (the "Site") is City owned and located at 1115 Chestnut Street in the Gateway Redevelopment Area.
- The former Reliable Tire Site (Block 1302, Lot 1) is City owned and located at 1115 Chestnut Street in the Gateway Redevelopment Area (the "Site").
- The Site is approximately two acres in size and is zoned per the Gateway Redevelopment Plan as Office /Light Industrial.
- CRA assessment activities have identified five underground storage tanks (USTs) at the Site.
- Additional sampling conducted at the Site indicates that there are three soil "hot spot" areas of contamination that require excavation and disposal so as to comply with NJDEP requirements for site remediation.
- CRA authorized by Resolution 04-12-23C a \$155,678.00 an increase in the Sub-grant amount to a total amount of \$274,203.00 to address the USTs and the remediation of the soil hot spots.
- CRA issued an Invitation for Bid for the required work and the lowest responsible bid received was substantially higher than the engineer's estimate.
- The actual costs for removal of the USTs and for addressing the contaminated soil hot spot areas will exceed the current amount of the Sub-grant awarded for this Site and requires an increase in the Sub-grant by the additional amount of \$225,797.00.
- The CRA, as the administrator of the City's Brownfield Program, will also manage the EPA RLF Sub-grant for remediation at the Reliable Tire Site.

Information of key municipal employee or agent applying for grant and responsible for its use:

Name	Olivette Simpson
Title	Interim Executive Director
Telephone Number	856-757-7600
Email	OlSimpso@ci.camden.nj.us

If the grant is received and fully expended, what will the continuing financial obligations of the municipality be with respect to staffing, insurance, liability, operations, and/or maintenance?

None

What will the source of funds be for the staffing, insurance, liability, operations, and /or maintenance?

N/A

 _____ Date 12/21/23

Olivette Simpson
Interim Executive Director Signature

Name, email and fax of contact person for this form:

Olivette Simpson, OlSimpso@ci.camden.nj.us 856-964-2262

For LGS use only:

Approved Denied

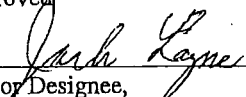
 _____
Director or Designee,
Division of Local Government Services

Date 12/21/23

Number Assigned CRA 2023-43

12-19-23E

Resolution Amending Resolution 04-12-23C to Authorize an Increase in a Sub-grant from \$274,203.00 to \$500,000.00 to the City of Camden from the U.S. Environmental Protection Agency Brownfields Revolving Loan Fund for the Environmental Remediation of Block 1302, Lot 1 of the City of Camden Tax Map

WHEREAS, the City of Camden Redevelopment Agency (“CRA”) is charged with the duty of redevelopment throughout the City of Camden; and

WHEREAS, as part of the CRA’s redevelopment duties, the CRA manages the Camden Brownfields Program on behalf of the City of Camden; and

WHEREAS, CRA by Resolution 08-07-13C applied for and accepted a Brownfields Revolving Loan Fund (“RLF”) Grant from the U.S. Environmental Protection Agency (“EPA”) to establish a Revolving Loan Fund and entered into EPA Cooperative Agreement 9628614 and the CRA by Resolution 06-08-22C applied for and accepted an additional RLF Grant from EPA and entered into EPA Cooperative Agreement 96236900 (together the “Cooperative Agreements”); and

WHEREAS, the Cooperative Agreements provide funding in the form of low to no-interest loans and Sub-grants that may be made available to conduct environmental cleanup of brownfield sites in the City of Camden; and

WHEREAS, the EPA RLF program guidelines allows for a grant recipient to make Sub-grants to non-profits and other units of local government for eligible projects and uses in an amount of up to \$500,000.00 per site; and

WHEREAS, the City owns land known as the former Reliable Tire site, designated as Block 1302, Lot 1 of the City of Camden Tax Map and described as 1115 Chestnut Street in the Gateway Redevelopment Area (the “Site”); and

WHEREAS, the Site requires environmental remediation including the removal of underground storage tanks and contaminated soil; and

WHEREAS, CRA authorized by Resolution 04-12-23C an amendment to increase the Sub-grant award to the City of Camden to \$274,203.00 under Cooperative Agreement 96236900 in part to address the additional soil contamination present at the Site; and

WHEREAS, CRA issued an Invitation for Bid on October 18, 2023 and the lowest responsible bid received was \$325,356.00 which is substantially higher than the engineer’s estimate to address the soil contamination at the Site; and

WHEREAS, the EPA program guidelines allow for award of a Sub-grant in an amount of up to \$500,000.00 for such purposes; and

WHEREAS, the additional funding amount of \$225,797.00 is available through EPA Cooperative Agreement 96236900 for a total Sub-grant of \$500,000 for the Site; and

12-19-23E (cont'd)

WHEREAS, CRA, as the administrator of the City's Brownfields Program, will also manage the Sub-grant and remediation of the Site through a Shared Services Agreement with the City of Camden, and

WHEREAS, the additional Sub-grant amount recommendation was reviewed and approved by the CRA Finance Committee.

NOW, THEREFORE, BE IT RESOLVED by the governing body of the City of Camden Redevelopment Agency that Resolution 04-12-23C is hereby amended to increase the amount of the Sub-grant to the City of Camden from \$274,203.00 to \$500,000.00 from the U.S. EPA Brownfields Revolving Loan Funds, pursuant to Cooperative Agreements 9628614 and 96236900 for the purpose of environmental remediation and related activities at the City owned-site designated as Block 1302, Lot 1 of the City of Camden Tax Map, and

BE IT FURTHER RESOLVED that the Interim Executive Director, or her designee, is hereby authorized to take all actions and execute all documents necessary to carry out the purposes of this resolution.

12-19-23E (cont'd)

ON MOTION OF: **Derek Davis**

SECONDED BY: **Tasha Gainey-Humphrey**

COMMISSIONER	AYES	NAYS	ABSTENTIONS
Christopher Collins			X
Derek Davis	X		
Gilbert Harden, Sr.			
Tasha Gainey-Humphrey	X		
Ian K. Leonard	X		
Jose Javier Ramos	X		
Maria Sharma			X

Ian K. Leonard

Ian K. Leonard
Chairperson

ATTEST:

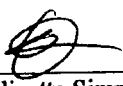

Olivette Simpson
Interim Executive Director

The above has been reviewed and approved as to form.

Mark P. Asselta

Mark P. Asselta, Esq.
Board Counsel

**CAMDEN REDEVELOPMENT AGENCY
US ENVIRONMENTAL PROTECTION AGENCY REVOLVING LOAN FUND
REMEDATION SUBGRANT SUMMARY & RECOMENDATIONS**

SUBGRANTEE: **City of Camden**
City Hall
520 Market Street
Camden, New Jersey 08101

PROJECT SUMMARY:

- The City of Camden (City) is requesting an increase of \$225,797 of the previously awarded subgrants of \$118,525 by Resolution 03-09-22F and of \$155,678 by Resolution 04-12-23C from the US Environmental Protection Agency (EPA) Brownfield Revolving Loan Fund (RLF) for remediation of the Reliable Tire Site (Block 1302, Lot 1). The Reliable Tire Site is located within the Gateway Redevelopment Area.
- During the CRA's assessment activities at the site, the presence of five (5) underground storage tanks (USTs) were discovered.
- Three of the USTs are registered with the NJ Department of Environmental Protection (NJDEP) and have been closed in place, however there does not appear to be any records on file with the NJDEP that they were properly closed. The other two USTs need to be registered with the NJDEP and properly closed.
- The Licensed Site Remediation Professional (LSRP) for the site has recommended that all five USTs be removed and disposed of to an appropriate facility off-site, in compliance with NJDEP regulations and requirements. And, to determine if any of the USTs have leaked into the soil.
- Further assessment activities conducted at the site indicates the presence of three soil "hot spot" areas of contamination that must be addressed.
- The engineers estimate for the UST and hot spot soil removal line item was \$93,800 with total remediation project costs estimated to be \$274,203. The CRA issued an invitation for bid. The lowest bid for the project substantially exceed the engineers estimate for the UST and hot spot soil removal line item to \$325,356.
- An additional \$225,797 is being requested for the project, bringing the total project budget to \$500,000.
- The Site is currently a City-owned property having been acquired by the City in 2018 via tax foreclosure.
- The Site is approximately two acres in size and is zoned per the Gateway Redevelopment Plan as Office / Light Industrial.
- RLF funding awarded to the CRA from EPA is available to address the planned remediation activities.

RECOMMENDED TERMS:

Subgrant Award:

Increase the prior authorized \$274,203 by \$225,797 for a total subgrant award of \$500,000.

Term: Not Applicable

Interest Rate: Not Applicable

Collateral: None

TOTAL PROJECT SOURCES AND USES TABLE is below:

PROJECT SOURCES		PROJECT USES	
EPA RLF Subgrant (initial award)	\$ 118,525	Engineering and Reporting	\$ 50,583
EPA RLF Subgrant (first increase)	\$ 155,678	Remediation Contractor	\$ 325,356
EPA RLF Subgrant (second increase)	\$ 225,797	NJDEP UST fees	\$ 7,100
		NJDEP RA fees	\$ 5,000
		Oversight	\$ 45,000
		CRA Fee	\$ 50,000
		Contingency (20% Contractual)	\$ 16,961
	<u>\$ 500,000</u>		<u>\$ 500,000</u>

RESOLUTION MC-23: 9080

On Motion Of: Sheila Davis
APPROVED: August 8th, 2023

Rev. 11-23

DB:dh
08-08-23

**RESOLUTION AUTHORIZING THE EXECUTION OF A SUB-GRANT AGREEMENT
BETWEEN THE CITY OF CAMDEN AND THE CAMDEN REDEVELOPMENT
AGENCY FOR GRANT FUNDS FROM THE U.S. ENVIRONMENTAL PROTECTION
AGENCY BROWNFIELDS REVOLVING LOAN FUND FOR THE
CLEAN-UP OF THE FORMER RELIABLE TIRE SITE 1115 CHESTNUT
(BLOCK 1302, LOT 1)**

WHEREAS, Camden Redevelopment Agency ("CRA") is the administrator and manager of the City of Camden's Brownfields Program; and

WHEREAS, the City is requesting the execution of a sub-grant agreement of \$274,203 from the U.S. Environmental Protection Agency Brownfield Revolving Loan Fund for the clean-up of the Former Reliable Tire Site known as 1115 Chestnut Street, Block 1302, Lot 1; and

WHEREAS, the CRA desires to give a Brownfields Revolving Loan Fund sub-grant in the amount of \$274,203 to the City of Camden for the remediation and environmental clean-up of the Property; and

WHEREAS, the City of Camden, desires to enter into a Sub-Grant Agreement with the CRA which will set forth the terms of the Sub-Grant; and

WHEREAS, City Council has determined that it is in the best interest of the City of Camden that the City enter into said Sub-Grant agreement; now, therefore

BE IT RESOLVED, by the City Council of the City of Camden that the proper officers are hereby authorized to execute a Sub-Grant Agreement with the Camden Redevelopment Agency governing the City's award of the Brownfields Revolving Loan Fund Sub-Grant in the amount of \$274,203 for the remediation and environmental clean-up of 1115 Chestnut Street, Block 1302, Lot 1.

BE IT FURTHER RESOLVED, by the City Council of the City of Camden that the City is hereby authorized to accept said Sub-Grant in the amount of \$274,203 from the CRA.

BE IT FURTHER RESOLVED, that pursuant to N.J.S.A. 52:27BBB-23, a true copy of this Resolution shall be forwarded to the State Commissioner of Community Affairs, who shall have ten (10) days from the receipt thereof to veto this Resolution. All notices of veto shall be filed in the Office of the Municipal Clerk.

Date: August 8, 2023

The above has been reviewed
and approved as to form.



DANIEL S. BLACKBURN
City Attorney



ANGEL FUENTES
President, City Council

ATTEST:



LUIS PASTORIZA
Municipal Clerk

US EPA BROWNFIELDS CLEAN-UP REVOLVING LOAN FUND

SUBGRANT AGREEMENT

BY AND BETWEEN THE CITY OF CAMDEN AS THE SUB-GRANTEE

AND

THE CITY OF CAMDEN REDEVELOPMENT AGENCY AS SUB-GRANTOR

SUBGRANT: \$274,203.00

PROPERTY: BLOCK 1302, LOT 1 – 1115 CHESTNUT STREET, CAMDEN NEW JERSEY

THIS SUB-GRANT AGREEMENT NO. 08-23-040 ("Agreement") is entered into as of this 21st day of September 2023 by and between THE CITY OF CAMDEN, a unit of local government (hereinafter called "SUB-GRANTEE"), and the CITY OF CAMDEN REDEVELOPMENT AGENCY as SUB-GRANTOR (hereinafter called "CRA").

WITNESSETH:

WHEREAS, the City of Camden Redevelopment Agency (CRA) is charged with the duty of redevelopment within the City of Camden; and

WHEREAS, to this end, the CRA is the administrator and manager of the Brownfields Program on behalf of the City of Camden; and

WHEREAS, the CRA by Resolution 08-07-13C applied for and accepted a Brownfields Revolving Loan Fund (RLF) Grant from the United States Environmental Protection Agency (US EPA) to establish a Revolving Loan Fund and entered into US EPA Cooperative Agreement BF9628614-0; and

WHEREAS, the CRA by Resolution 06-08-22C applied for and accepted an additional RLF Grant from US EPA and entered into Cooperative Agreement 96236900-0 (together the "Cooperative Agreements"); and

WHEREAS, the Cooperative Agreements provide funding in the form of low to no-interest loans and sub-grants that may be made available in support of environmental cleanup of Brownfield sites in the City of Camden, and

WHEREAS, the US EPA Brownfields RLF Program allows for a grant recipient to make sub-grants to non-profits and other units of local government for eligible projects and uses, and

WHEREAS, the City of Camden owns a property designated as Block 1302, Lot 1 of the City of Camden Tax Map and described as 1115 Chestnut Street, Camden, New Jersey (the "Property"),

WHEREAS, the Property is determined by US EPA to be an eligible project and the use of the RLF Sub-Grant funds are necessary for the remediation of the site, which includes without limitation the removal and off-site disposal of contaminated soil material and associated costs; and

WHEREAS, CRA on behalf of the City and as the administrator of the City of Camden's Brownfields Program will also manage the US EPA RLF Sub-Grant funds for the remediation of the Property; and

WHEREAS, by Resolution #03-09-22F as amended by #04-12-23C the governing body of the CRA authorized a US EPA Sub-Grant to the City of Camden in an amount not to exceed \$274,203.00 and execution of a Sub-Grant Agreement for the purpose of environmental cleanup of the Property; and

WHEREAS, by Resolution MC-23:9080 the governing body of the City of Camden authorized the execution of this Sub-Grant Agreement.

NOW, THEREFORE, in consideration of the mutual promises herein contained and for other valuable consideration, the parties hereto agree as follows:

1. SUB-GRANT AMOUNT:

Amount of Sub-grant: TWO HUNDRED AND SEVENTY-FOUR THOUSAND AND TWO HUNDRED AND THREE DOLLARS AND 00/100 (\$274,203.00).

2. AVAILABILITY

This Sub-grant will be effective upon the execution of this Sub-Grant Agreement and other necessary documents. Funds shall be for eligible expenses based upon the progress of the work and in accordance with Exhibit A.

3. USE OF PROCEEDS:

The CRA on behalf of the City and as administrator of the City of Camden's Brownfield's Program shall administer and manage the use the Sub-Grant funds for the abatement and removal of environmental hazards located on property owned by the City of Camden and designated as Block 1302, Lot 1 of the City of Camden Tax Map and located at 1115 Chestnut Street in Camden, New Jersey (the "Property") in accordance with all provisions of Brownfields Cleanup Revolving Loan Fund. CRA will use the Funds to pay invoices for costs associated with environmental remediation of the Property as more particularly described on Exhibit A ("Eligible Costs"). If the Funds are used for eligible sampling purposes, such sampling will be conducted as outlined in an EPA-approved Quality Assurance Project Plans ("QAPP") prepared for the Property. CRA shall pay the full amount shown as due on each invoice to the party named on the invoice of being entitled to receive the payment. CRA shall not use the proceeds of the Sub-grant funds for activities others than those described within Exhibit A.

4. SUB-GRANTEE REPRESENTS, WARRANTIES, COVENANTS AND AGREES WITH CRA THAT:

- SUB-GRANTEE certifies that the Property is presently and will continue to be owned by the SUB-GRANTEE who shall keep same free from all liens, security interests and encumbrances other than those made in favor of the CRA for the duration of the Sub-grant funded environmental remediation. The SUB-GRANTEE covenants to pay any and all taxes, license fees or any and all other associated charges when due in connection with the Property. The SUB-GRANTEE will comply with all state and federal laws, rules, and regulations with respect to the ownership of the Property.
- SUB-GRANTEE certifies that Property is not listed, nor proposed for listing on the National Priorities List of the U. S. Environmental Protection Agency, and is not subject to a Federal or state response or enforcement.
- SUB-GRANTEE certifies that it is not responsible for the existing environmental hazards as a generator or transporter of the contamination pursuant to the Comprehensive Environmental, Response, Compensation, and Liability Act of 1980, as amended (CERCLA).
- SUB-GRANTEE certifies that it is not currently, nor has been subject to any penalties resulting from environmental non-compliance at the Property that is subject to this Sub-grant.
- SUB-GRANTEE certifies that they have not been suspended, debarred, or otherwise declared ineligible to receive Federal assistance.
- The CRA certifies that Sub-grant funds shall only be used to carry out eligible non time critical removal activities authorized by CERCLA and the NCP at 40 CFR 300.415(e).
- The CRA certifies Sub-grant funds will not be used for the following activities: 1) to address contamination exclusively from petroleum products except to address a non-petroleum hazardous substance; 2) pre-cleanup environmental response activities, such as site assessment, identification and characterization; 3) cleanup of a naturally occurring substance, products that are part of the structure of and result in exposure within residential buildings or business or community structures, or public or private drinking water supplies that have deteriorated through ordinary use-except as determined on a site by site basis and approved by U.S. EPA, consistent with CERCLA Sections 104(a)(3) and (4); 4) monitoring and data collection necessary to apply for, or comply with, environmental permits under other Federal and state laws, unless such a permit is required as a component of the cleanup action; 5) development activities that are not removal actions; 6) job training; or 7) lobbying efforts.
- The CRA, or CRA designee, using the foregoing information and any other necessary information shall prepare a draft Analysis of Brownfield Cleanup Alternatives (ABCA) documenting that the cleanup meets the CERCLA and NCP criteria for initiating a non-time critical removal action.

- After the CRA signs off on said ABCA, it shall prepare a Community Relations Plan (CRP) with the assistance and cooperation of the SUB-GRANTEE. Said CRP shall include:
 - a) Plan for outreach with and solicitation of feedback on the cleanup from residents and community leaders, local officials, and public interest groups.
 - b) Plan for disseminating news and information regarding the remediation throughout the surrounding affected area.
 - c) Establishing a local information repository at or near the potential site that includes public information supplied by both the CRA and the SUB-GRANTEE related to the proposed remediation. SUB-GRANTEE shall supply to the CRA any information, which is necessary and reasonable to establish the information repository.

- Upon completion of the ABCA and implementation of the CRP, the CRA, or the CRA designee, shall prepare a Decision Memo substantiating the need for the site cleanup and removal action. SUB-GRANTEE shall supply all information as necessary for the completion of the Decision Memo by the CRA, or CRA designee.

- It is understood and agreed by CRA that the ultimate objective of use of Sub-grant funds is to cleanup, improve and revitalize the subject Property and the surrounding area, which will benefit both the SUB-GRANTEE and the community.

- It is understood and agreed by the CRA that the cleanup of the site shall commence and a documented request for first draw down of the Sub-Grant shall be made on or before January 1, 2023.

- The CRA or their designee shall inspect work at the Property during and upon completion of the cleanup activities. The CRA shall, at all times, have the right to enter the Property during the execution of the Remedial Action Work plan, or equivalent. The CRA, upon a finding that the work is unsatisfactory or is not substantially in accordance with the activities described within Exhibit A, shall have the right to stop work and order work replacement.

- The CRA shall continually monitor the work performed until the project is completed in a good and workmanlike manner. No installments shall be advanced by the CRA for which payment is being requested unless work has been satisfactorily performed in accordance with CERCLA and the NCP.

- The CRA agrees to keep all expenditures within the approved budget using funds only for eligible purposes and shall maintain records which segregate expenditures from Federal and non-Federal sources. It is hereby understood and agreed that the CRA shall not exceed any of the costs enumerated in said budget. In the event that unforeseen conditions are discovered during the Project implementation, the CRA reserves the right to revise this agreement provided the proposed revision is reasonable and cost effective.

- The CRA shall be responsible for obtaining all permits, licenses, zoning changes, variances or exceptions and all inspections required by federal, state and local agencies.

- All requests for progress payments will be made on a monthly basis and shall be approved by the CRA. The CRA shall be responsible for taking such measures as may be appropriate to verify that each invoice reflects an Eligible Cost and is appropriate for payment, and for determining that lien waivers or other documents that may be required as a condition to payment are present. If a particular invoice has been approved only in part, the CRA shall indicate in writing the amount for which payment is approved. The CRA shall disburse the Funds based upon the progress of the work completed and based upon receipt of a satisfactory documentation of expenditures. The SUB-GRANTEE and CRA acknowledge that the Cooperative Agreement with the U. S. Environmental Protection Agency is the source of all Funds and that the CRA is under no obligation to disburse any of its own funds to the SUB-GRANTEE or anyone else for the Project.
- The CRA agrees to complete the Project in accordance with the applicable provisions of CERCLA, the NCP (40 CFR 300) and the Davis-Bacon Act of 1931 and all other applicable cross-cutting federal and state statutes, rules, regulations and requirements.
- The CRA shall not discriminate on the basis of race, creed, color, sex, age, handicap, marital status, sexual preference, national origin or any other basis prohibited by law. The CRA shall make reasonable outreach efforts to inform minority and women owned businesses of opportunities to participate in the work performed pursuant to this Sub-Grant Agreement.
- SUB-GRANTEE may not sell, transfer or exchange all or any portion of the Property without the CRA's prior written consent until the Sub-grant funded work is completed. Should SUB-GRANTEE elect to sell or transfer the Property prior to completion of the Project, then the SUB-GRANTEE shall repay the entire amount of Sub-grant funds dispersed plus ten (10%) of the Sub-grant amount due as a penalty.
- The CRA shall maintain documentation for a minimum of SEVEN years after the completion of the cleanup activity supported by the Sub-grant with written approval from the CRA required prior to destroying any Project records.
- The CRA shall be responsible for providing and installing a sign at each site containing information about contacts and activities regarding the site.
- The CRA will have a system of accounting in place that can maintain records and track site specific costs, and track costs by activity and operable unit.
- The CRA shall furnish annual financial statements prepared in accordance with generally accepted accounting principles and practices and any other financial information that CRA may reasonably request. Financial reports will show amount of funds received and expended, direct and indirect project costs.
- The CRA will make available all records regarding property use, procurement methods, and documentation of compliance with pertinent statutes and regulations.

5. EVENTS OF DEFAULT:

An event of default shall exist if any one or more of the following events (hereinafter referred to as "Events of Default") shall occur:

- a. When the SUB-GRANTEE sells, abandons or otherwise transfers ownership interest in any of the Property securing this Sub-grant, without prior written consent of the CRA.

6. REMEDIES IN THE EVENT OF DEFAULT:

If an event of default, as set forth above, shall have occurred without cure the CRA may exercise any one or more of the following rights and remedies and any other remedy provided herein:

- a. May terminate any and all commitments made herein by the CRA.
- b. Declare the penalties prescribed herein as due and payable and whereupon all such payments of become due and payable without presentment demand and/or notice of default.
- c. In addition to the remedies prescribed above in connection with events of default the CRA shall have all rights and remedies provided it under the Uniform Commercial Code. It is specifically provided herein that the remedies set forth above including those prescribed in the Uniform Commercial Code be deemed cumulative and not exclusive.

7. NEW JERSEY LAW:

This Sub-Grant Agreement is being executed and delivered and is intended to be performed in the State of New Jersey. Except to the extent that the laws of the United States may apply to the terms hereof, the substantive laws of the State of New Jersey shall govern the validity, construction, enforcement and interpretation of this Sub-Grant Agreement. In the event a dispute involving this Sub-Grant Agreement or any other instrument executed in connection herewith arises, the undersigned irrevocably agrees that venue for such dispute shall lie in any Court of competent jurisdiction in the Hudson County and State of New Jersey.

8. ATTORNEY'S FEES:

If this Sub-Grant Agreement and/or any other document executed in connection herewith is placed in the hands of an attorney for collection or if it is collected through any legal proceedings at law or in equity or in bankruptcy, receivership or other court proceedings, the SUB-GRANTEE promises to pay all costs and expenses of collection including, but not limited to, Court costs and a reasonable attorney's fees of the CRA hereof. The parties hereto specifically agree that the term "reasonable attorney's fees" is to be construed to include any and all costs and charges in connection with obtaining possession of the Property and subsequent completion of the remediation activities thereof.

9. NOTICE:

All notices required or permitted by this "Agreement" shall be in writing and shall be sent by United States Certified or Registered Mail, Return Receipt Requested, or by way of Overnight Courier for personal delivery.

All said notices shall be sent to the following:

As To CRA

Executive Director
City of Camden Redevelopment Agency
City Hall – 13th Floor
Camden, New Jersey 08101

As To SUB-GRANTEE

City Attorney
City of Camden
520 Market Street
City Hall
Camden, New Jersey 08101

10. MODIFICATIONS:

The CRA and SUB-GRANTEE hereto specifically agree that the terms of this Sub-Grant Agreement can only be changed by virtue of a modification of agreement reduced to writing and signed and executed by both parties hereto. Further the parties hereto specifically agree that the Sub-grant documents embody the entire agreement between the parties and supersede and replace any and all prior agreements and/or understandings or representations made, if any, relating to the subject matter hereof.

11. INDEMNITY:

The SUBG-GRANTEE irrevocably agrees to protect and defend, indemnify, and hold the U.S. Environmental Protection Agency, and the CRA, and its commissioners, directors, officers, employees, representatives or agents free and harmless from and against any and all losses, claims, liens, demands and causes of action of every kind and character including the amount of judgments, penalties, interest, court costs, and legal fees incurred by the CRA in defense of same, arising in favor of taxes, claims, liens, debts, personal injuries including employees of the CRA, death or damages to property (including property of the CRA) and without limitations by enumeration, all other claims, or demands of every character occurring and caused in whole or in part by any negligent act or omission of the SUB-GRANTEE, any one directly or indirectly employed by the SUB-GRANTEE or anyone for whose acts company may be liable regardless of whether or not it is caused in part by the CRA.

12. INSURANCE:

The CRA shall cause its contractors and subcontractors shall carry and maintain in full force and effect for the duration of the Project appropriate insurance including coverage for Worker's Compensations and Employers Liability, Comprehensive General Liability, Professional Liability, and Comprehensive Automobile Liability Insurance, all in amounts acceptable to the CRA. All insurance certificates must name the SUB-GRANTEE, CRA, U. S. Environmental Protection Agency as additional insureds on the policy. Said Certificate must state that coverage cannot be cancelled or materially altered without thirty (30) days written notice to the CRA. Policies shall be issued by an insurance company authorized to do business in the State of New Jersey.

13. INVALID PROVISIONS:

If any provision of any Sub-Grant document is held to be illegal, invalid or unenforceable under present or future laws during the term of this Agreement such provision shall be fully severable and the remaining provisions of such Sub-grant document shall remain in full force and effect.

14. BINDING EFFECT:

The Sub-grant documents and all of them, shall be binding upon and inured to the benefit of the SUB-GRANTEE and the CRA and their respective successors, assigns and legal representatives provided, however, that the SUB-GRANTEE may not without prior written consent of the CRA assign any rights, powers, duties and/or obligations contained herein to any third party.

IN WITNESS WHEREOF, the undersigned have executed this Sub-Grant Agreement as of the day and year set forth above.

Attest:



LUIS PASTORIZA
Municipal Clerk

CITY OF CAMDEN

By:



VICTOR G. CARSTARPHEN
Mayor

Approves as to form:



DANIEL S. BLACKBURN, ESQ.
City Attorney

CITY OF
CAMDEN REDEVELOPMENT AGENCY

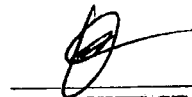

OLIVETTE SIMPSON
Interim Executive Director

INDEX OF EXHIBITS

- A. Identification of Eligible Costs
- B. City of Camden Authorizing Resolution
- C. City of Camden Redevelopment Agency Authorizing Resolution

1

Exhibit A: Identification of Eligible Costs

PROJECT SOURCES

EPA RLF Subgrant (initial award)	\$	118,525
EPA RLF Subgrant (increase)	\$	155,678
HDSRF (prior award)	\$	15,157
		<hr/>
	\$	289,360

PROJECT USES

Engineering and Reporting	\$	50,583
Remediation Contractor	\$	93,800
NJDEP UST fees	\$	7,100
NJDEP RA fees	\$	5,000
Oversight	\$	45,000
CRA Fee	\$	50,000
Contingency (20% Contractual)	\$	37,877
		<hr/>
	\$	289,360

RESOLUTION MC-23: 9079

On Motion Of: Sheila Davis
APPROVED: August 8th, 2023

R-19

DB:dh
08-08-23

**RESOLUTION AUTHORIZING A SHARED SERVICES AGREEMENT WITH
THE CAMDEN REDEVELOPMENT AGENCY FOR THE MANAGEMENT OF A
U.S. ENVIRONMENTAL PROTECTION AGENCY BROWNFIELDS REVOLVING
LOAN FUND SUB-GRANT FOR THE ENVIRONMENTAL REMEDIATION OF
BLOCK 1302, LOT 1 (1115 CHESTNUT STREET)**

WHEREAS, the City of Camden Redevelopment Agency ("CRA") is charged with the duty of redevelopment throughout the City of Camden; and

WHEREAS, as part of the CRA's redevelopment duties, the CRA manages the City of Camden Brownfields Program including Brownfield planning activities, applying for and managing grants for brownfield investigation and remediation, and contracting for associated professional services and remediation activities; and

WHEREAS, the City owns a site designated as 1115 Chestnut Street, Block 1302, Lot 1, on the City of Camden Tax Map and known as the 1115 Chestnut Street known as the former reliable tire site in the Gateway Redevelopment Plan; and

WHEREAS, environmental assessment activities conducted at the property indicate underground storage tanks required by NJDEP to be removed from the site as well as contaminated soil hot spots be excavated and soil disposed of to an appropriate off-site facility and backfill site with clean soil material; and

WHEREAS, the CRA is able to seek funding and cause to be performed the project's brownfield planning, assessment, remediation, and redevelopment; and

WHEREAS, the CRA and City desire to enter into a Shared Services Agreement for the CRA to secure and manage brownfield revolving loan fund sub-grant for the environmental and professional services in connection with the 1115 Chestnut Street remediation and environmental clean-up; now, therefore

BE IT RESOLVED by the governing body of the City of Camden Redevelopment Agency that the Executive Director of the Agency, a duly authorized representative of the Agency, is hereby authorized to negotiate and enter into a Shared Services Agreement with the City of Camden for the CRA to secure and manage brownfield funding and contract for the remediation and environmental clean-up and professional services in connection with the 1115 Chestnut Street site for a term of two (2) years from the execution of the agreement.

BE IT FURTHER RESOLVED, that pursuant to N.J.S.A. 52:27BBB-23, a true copy of this Resolution shall be forwarded to the State Commissioner of Community Affairs, who shall have ten (10) days from the receipt thereof to veto this Resolution. All notices of veto shall be filed in the Office of the Municipal Clerk.

Date: August 8, 2023

The above has been
reviewed and approved
as to form.

DANIELS. BLACKBURN
City Attorney

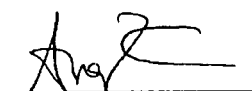
ANGEL FUENTES
President, City Council

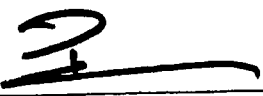
ATTEST: 
LUIS PASTORIZA
Municipal Clerk

04-12-23B

Resolution Authorizing a Shared Services Agreement with the City of Camden for the Management of a U.S. Environmental Protection Agency Brownfields Revolving Loan Fund Sub-Grant for the Environmental Remediation of the Former Reliable Tire Site Designated as Block 1302, Lot 1 of the City of Camden Tax Map in the Gateway Redevelopment Area

WHEREAS, the City of Camden Redevelopment Agency ("CRA") is charged with the duty of redevelopment throughout the City of Camden; and

WHEREAS, as part of CRA's redevelopment duties, CRA manages the Camden Brownfields Program on behalf of the City of Camden; and

WHEREAS, CRA by Resolution 08-07-13C applied for and accepted a Brownfields Revolving Loan Fund ("RLF") Grant from the U.S. Environmental Protection Agency ("EPA") to establish a Revolving Loan Fund and entered into EPA Cooperative Agreement 9628614; and

WHEREAS, CRA by Resolution 06-08-22C applied for and accepted an additional RLF Grant from EPA and entered into EPA Cooperative Agreement 96236900 (together with Cooperative Agreement 9628614, the "Cooperative Agreements"); and

WHEREAS, the Cooperative Agreements provide funding in the form of low to no-interest loans and Sub-Grants that may be made available to conduct environmental cleanup of brownfield sites in the City of Camden; and

WHEREAS, the EPA RLF program guidelines allows for a Grant recipient to make Sub-Grants to non-profits and other units of local government for eligible projects and uses in an amount of up to \$500,000 per site; and

WHEREAS, the City owns land designated as Block 1302, Lot 1 on the City of Camden Tax Map described as 1115 Chestnut Street in the Gateway Redevelopment Area (the "Site"); and

WHEREAS, CRA Board in a companion resolution, is being requested to authorize a Sub-Grant to the City in the amount of \$274,203.00 from the US EPA RLF fund for the purpose of environmental cleanup and related activities at the Site, and

WHEREAS, CRA, as the administrator of the City's Brownfields Program, seeks the Board's authorization to enter into a shared services agreement with the City of Camden to manage the US EPA RLF Sub-Grant and remedial activities at the Site for a fee that will be negotiated with the City.

NOW, THEREFORE, BE IT RESOLVED by the governing body of the City of Camden Redevelopment Agency, that the Agency is hereby authorized to enter into a Shared Services Agreement with the City of Camden to manage a U.S. Environmental Protection Agency Revolving Loan Fund Sub-Grant in an amount of up to \$ 274,203.00 to be used for environmental remediation and related activities at the City owned-site designated as Block 1302, Lot 1 of the City of Camden Tax Map and described as 1115 Chestnut Street; and

BE IT FURTHER RESOLVED that the Interim Executive Director, or her designee, is hereby authorized to take all actions and execute all documents necessary to carry out the purposes of this resolution.

04-12-23B (cont'd)

ON MOTION OF: Jose Javier Ramos

SECONDED BY: Tasha Gainey-Humphrey

COMMISSIONER	AYES	NAYS	ABSTENTIONS
Christopher Collins			
Derek Davis			
Gilbert Harden, Sr.	X		
Tasha Gainey-Humphrey	X		
Ian K. Leonard	X		
Jose Javier Ramos	X		
Maria Sharma			

Ian K. Leonard

Ian K. Leonard
Chairperson

ATTEST:



Olivette Simpson
Interim Executive Director

The above has been reviewed and approved as to form.

Mark P. Asselta

Mark P. Asselta, Esq.
Board Counsel

**SHARED SERVICES AGREEMENT BETWEEN THE CITY OF CAMDEN
AND THE CAMDEN REDEVELOPMENT AGENCY FOR THE MANAGEMENT OF
THE BROWNSFIELDS REVOLVING LOAN FUND SUBGRANT**

THIS SHARED SERVICES AGREEMENT ("Agreement") No. 08-23-039 is entered into this 29th day of September, 2023, between the City of Camden ("City"), a municipal corporation of the State of New Jersey with its principal offices located at 520 Market Street, 4th Floor, Camden, NJ 08102, and the Camden Redevelopment Agency ("CRA"), with its principal offices located at 520 Market Street, 13th Floor, Camden, NJ 08102.

WITNESSETH:

WHEREAS, N.J.S.A. 40A:65-1 authorizes local units of government to enter into agreements for shared services; and

WHEREAS, the CRA is charged with the duty of redevelopment throughout the City; and

WHEREAS, as part of its redevelopment duties the CRA manages the City's Brownfields Program including applying for and managing grants for brownfield investigation and remediation, and contracting for professional services and remediation activities; and

WHEREAS, the City owns a site located at 1115 Chestnut Street and designated as Block 1302, Lot 1 ("Property"), on the City of Camden Tax Map known as the former "Reliable Tire" site in need of environmental remediation; and

WHEREAS, on August 8, 2023, the Camden City Council by Resolution MC-23:9079 authorized the execution of this Agreement; and

WHEREAS, on April 12, 2023, the governing body of the CRA by Resolution 04-12-23B authorized execution of this Agreement; and

WHEREAS, it is now necessary to enter into a Shared Services Agreement with the CRA establishing the responsibilities of the parties, terms and conditions; now, therefore;

AGREEMENT

1. TERM

This Agreement shall commence on the date written above for a period of two (2) years.

2. SCOPE OF SERVICES

A. The CRA shall undertake the following tasks on behalf of the City:

- Secure and manage brownfield funding for environmental and professional services in connection with remediation efforts of the Property; and
- Perform grant reporting activities as well as serve as a liaison with environmental regulatory and funding agencies; and
- Participate in and/or conduct community engagement activities, as needed; and
- Facilitate the environmental assessment and remediation activities at the site to advance construction of park improvements.

B. The City shall:

- Execute all relevant documents necessary for the CRA to secure, manage/administer grants and/or other funding for the environmental investigation, assessment, and remediation of the Park Site leading to the construction of the Park Improvements; and
- The City will be responsible for maintenance, security, and responsibility of and for the Site.

3. AUDIT

Pursuant to the Single Audit Act of 1984, both parties agree to permit either party and/or its agents to examine any and all records relevant to this Agreement and shall make the same available upon demand at a reasonable time and place for the purpose of auditing the records

4. OPEN PUBLIC RECORDS ACT ("OPRA")

CRA shall work cooperatively with the City to provide documents and offer support as necessary to assist the City in addressing and/or responding to any OPRA request received by the City related to this Agreement.

5. MUTUAL INDEMNIFICATION

Each party agrees to indemnify and hold harmless the other party, its officers, directors, and employees, against all damages, liabilities and costs, including reasonable attorneys' fees; but, only to the extent caused by each party's negligent acts in connection with the Services under this Agreement and the acts of anyone for whom each party is legally liable.

6. RIGHT TO INSPECT

Both parties to this Agreement shall permit either party or its authorized representatives to make visits to the site or sites where the Services are being provided for the purpose of assuring each party's compliance with the terms of this Agreement.

7. TERMINATION OF AGREEMENT

This Agreement may be terminated in whole or in part by either party for any reason upon thirty (30) days prior written notice from one party to the other.

8. CONSTRUCTION OF THIS AGREEMENT

The parties acknowledge that this Agreement was prepared under New Jersey Law and shall, therefore, be interpreted under the Laws of the State of New Jersey.

9. AMENDMENTS

This Agreement may not be amended, altered or modified in any manner except in writing signed by the parties hereto.

10. ENTIRE AGREEMENT

This written Agreement represents the entire understanding of the parties.

{Remainder of page intentionally left blank; signature page to follow}

IN WITNESS WHEREOF, and intending to be bound hereby, the parties hereto have caused this Agreement to be duly executed as of the day and year first above written.

Attest:

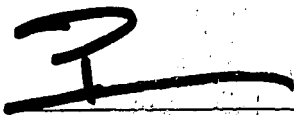

LUIS PASTORIZA
Municipal Clerk

CITY OF CAMDEN

By:

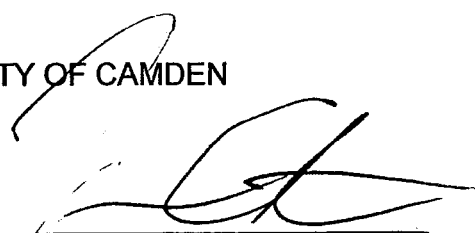

VICTOR CARSTARPHEN
Mayor

Approved as to form:



DANIEL S. BLACKBURN
City Attorney

CAMDEN REDEVELOPMENT
AGENCY

By:



OLIVETTE SIMPSON
Interim Executive Director

R-38

DB:dh
03-12-24

**RESOLUTION AUTHORIZING THE CONTINUE RENTAL
OF ONE (1) REAR LOADER FROM BIG TRUCK RENTAL**

WHEREAS, the Council of the City of Camden by Resolution MC-22:8741, dated December 13, 2022, awarded a contract to Big Truck Rental under the OMNIA PARTNERS public sector cooperative purchasing contract #2019000319; and

WHEREAS, the contract price set forth in MC-22:8741 was Fifty-One Thousand Dollars (\$51,000.00); and

WHEREAS, the Council of the City of Camden by Resolution MC-23:8962 adopted on May 9, 2023, extended the rental for one (1) 2022 Peterbilt rear loader from Big Truck Rental until December 21, 2023 in the amount of EIGHTY-SIX THOUSAND TWENTY-FIVE DOLLARS (\$86,025.00); and

WHEREAS, it is necessary to further extend the rental of one (1) 2022 Peterbilt rear loader from Big Truck Rental until December 21, 2024 in the amount of ONE HUNDRED TWO THOUSAND DOLLARS (\$102,000.00); and

WHEREAS, pursuant to the directive of the Division of Local Government Services, a certification has been attached hereto which certifies that the funds for this expenditure are available and appropriated under the budget of the City of Camden, under line item(s) "4-01-E6-702-917", said certification has been signed by the Chief Financial Officer and approved as to form by the City Attorney; now, therefore

BE IT RESOLVED, that the City Council of the City of Camden hereby approves to continue the rental of one (1) 2022 Peterbilt rear loader from Big Truck Rental until December 21, 2024 in the amount not to exceed ONE HUNDRED TWO THOUSAND DOLLARS (\$102,000.00).

BE IT FURTHER RESOLVED, that pursuant to N.J.S.A. 52:27BBB-23, a true copy of this Resolution shall be forwarded to the State Commissioner of Community Affairs, who shall have ten (10) days from the receipt thereof to veto this Resolution. All notices of veto shall be filed in the Office of the Municipal Clerk.

Date: March 12, 2024

The above has been reviewed
and approved as to form.



DANIEL S. BLACKBURN
City Attorney

ANGEL FUENTES
President, City Council

ATTEST: _____
LUIS PASTORIZA
Municipal Clerk

CITY OF CAMDEN

CERTIFICATION AS TO THE AVAILABILITY OF FUNDS

I CERTIFY, DIRECTOR FOR THE FINANCE DEPARTMENT FOR THE CITY OF CAMDEN, THAT WITH RESPECT TO THE AWARD OF A CONTRACT OR EXPENDITURE OF FUNDS TO: BIG TRUCK RENTAL

THAT THE FUNDS ARE AVAILABLE AS OF THE DATE OF THIS RESOLUTION/CERTIFICATION, FROM ONE OF THE FOLLOWING:

- BUDGET APPROPRIATION:4-01-E6-702-917
AMOUNT: \$ 102,000.00
- DEDICATED BY RIDER:
AMOUNT:\$
- TEMPORARY RESERVE FOR STATE AND FEDERAL GRANT:
AMOUNT:\$
- CAPITAL ORDINANCE
AMOUNT:\$
- TRUST ACCOUNT:
AMOUNT: \$

DETERMINATION OF VALUE CERTIFICATION

I CERTIFY, AS CHIEF FINANCIAL OFFICER, THAT THE ANTICIPATED VALUE OF THE CONTRACT, OVER THE FULL LIFE, WILL BE: \$ 102,000.00

DESCRIPTION OF THE GOODS AND SERVICES TO BE PROCURED: RESOLUTION AUTHORIZING THE CONTINUE RENTAL OF ONE(1) REAR LOADER FROM BIG TRUCK RENTAL .

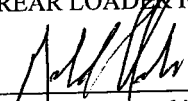

Gerald C. Seneski
Director of Finance
Date: 2/21



CITY OF CAMDEN — CITY COUNCIL ACTION REQUEST FORM

COUNCIL MEETING DATE: 03/12/2024

TO: City Council
FROM: KEITH L. WALKER, DIRECTOR OF PUBLIC WORKS

TITLE OF ORDINANCE/RESOLUTION: RESOLUTION AUTHORIZING THE CONTINUE RENTAL OF ONE (1) REAR LOADER FROM BIG TRUCK RENTAL

Point of Contact:	Lateefah Chandler	Admin-Purchasing	856-757-7475	lachandl@ci.camden.nj.us
	Name	Department-Division-Bureau	Phone	Email

ENDORSEMENTS

	Recommend Approval (Y/N)	Signature	Date	Comments
Responsible Department Director	Y			
Supporting Department Director (if necessary)				
Director of Grants Management				
Qualified Purchasing Agent	Y		2/2/2024	
Director of Finance	Y		2/2	
Approved by: Business Administrator			2/2	

Attachments (list and attach all available):

1. Waiver Request Form Attached for State DCA/DLGS Approval - (If applicable)¹
2. Certification of Funds²
3. Addition supporting documents.

“Walk-on” note: All walk-on legislation must be pre-approved by the Business Administrator. The Department Director and Contact Person are jointly responsible for delivering all necessary documents to the City Clerk for distribution at the Council Meeting.

FEB 29 2024

Received by:		
City Attorney	Signature	Date

¹ For Example: Form “A” - Request for approval of Employees Requiring Advice and Consent of Governing Body, Form “D” - Contract Request, Form “E” - Creation/Extension of Services, Form “G” - Grant Approval, Form “H” - Bond Ordinance or Contract Request, Form “I”, “Best Price Insurance Contracting” Model Ordinance
² Mandatory for any financial commitment to the City or expenditure of City Funds.

**STATE OF NEW JERSEY
DEPARTMENT OF COMMUNITY AFFAIRS
DIVISION OF LOCAL GOVERNMENT SERVICES
CONTRACT REQUEST FORM**

This form must be filled out in its entirety and is intended to provide the Division with appropriate information to determine whether to approve a new or extended service. Please provide any additional information you believe will help the Division make an informed decision.

Municipality	CITY OF CAMDEN
--------------	----------------

Professional Service or EUS Type	N/A
Name of Vendor	BIG TRUCK RENTAL
Purpose or Need for service:	RENTAL OF 2022 PETERBILT REAR LOAD
Contract Award Amount	\$102,000.00
Term of Contract	10 MONTHS
Temporary or Seasonal	N/A
Grant Funded (attach appropriate documentation allowing for service through grant funds)	NO
Please explain the procurement process (i.e. bids, RFQ, competitive contracting, etc.)	NJSC NJSA 52:34-6.2(b)(3)
Were other proposals received? If so, please attach the names and amounts for each proposal received?	N/A

Please attach the RFP, evaluation memoranda or evaluation forms used to evaluate the vendors and a list of all bidders and the bid amounts associated with each bidder.

If the lowest bidder was not selected, please have the appropriate personnel sign the certification on page 2.

_____ Date _____
Mayor's Signature*

_____ Date _____
Business Administrator/Manager Signature

*For direct appointments of the Governing Body, Council President or at the discretion of the Director, the most senior member of the Governing Body may sign the waiver in lieu of the Mayor.

The Financial Officer affirms that there is adequate funding available for this action.

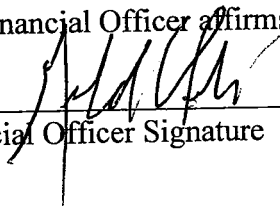

Financial Officer Signature

I certify that the vendor selected is in compliance with the adopted Pay to Play Ordinance and that the vendor was notified of any restrictions with respect to campaign contributions.

N/A N/Se Date _____
Certifying Officer

For LGS use only: _____
 Approved Denied

Date _____
Director or Designee,
Division of Local Government Services

Number Assigned _____

CAMDEN CITY
 520 MARKET STREET
 P.O BOX 95120
 CAMDEN, NJ 08101-5120
 TEL (856)757-7000

REQUISITION	
NO.	R2400183

SHIP TO	DEPT OF PUBLIC WORKS 101 NEWTON AVENUE CAMDEN, NJ 08103 ATTN: ACHANDLER
	VENDOR #: BIG03 BIG TRUCK RENTAL, LLC 4221 W BOY SCOUT BLVD STE 400 TAMPA, FL 33607

ORDER DATE: 01/16/24
 DELIVERY DATE: 01/16/24
 STATE CONTRACT: OMNIA2019000319
 F.O.B. TERMS:

WMS
30 yard loader
2.95 loadpacker

QTY/UNIT	DESCRIPTION	ACCOUNT NO.	UNIT PRICE	TOTAL COST
3.00 MTH	RENTAL OF 2022 PETERBILT REAR LOADER LOADPACKER (25YD) FOR TRASH PICKUPS COST PER MONTH = 4 WEEK PERIOD = \$8500.00 RES #: 23 RES DATE 5/9/2023 TOTAL COST NTE \$ 25,500 <i>Another year</i>	4-01-E6-702-917	8,500.0000	25,500.00
			TOTAL	25,500.00

30 yard
 PURCHASING BUREAU
 2024 JAN 19 AM 9:35

Approved: *[Signature]*

I hereby certify that the work or supplies specified are necessary for the proper transaction of the business of this bureau or office.

[Signature]
 Department Head
 1-18-24
 Date

[Signature] 1/17/2024
 Receiver of Goods
 Date

THIS COPY OF THE REQUISITION TO BE FORWARDED TO THE PURCHASING BUREAU

EXECUTIVE SUMMARY

TITLE OF ORDINANCE/RESOLUTION: RESOLUTION AUTHORIZING THE CONTINUE RENTAL OF ONE (1) REAR LOADER FROM BIG TRUCK RENTAL

FACTS/BACKGROUND: (Executive level details. Short concise bullets)

- Extending rental of 2022 Peterbilt rear loader until approximately December 21, 2024
- Rear loader needed for daily supplemental trash pickups, city-wide and mayor cleanups.
- Currently purchasing 2 rear loaders – will return rental once the rear loader(s) on order is received – delivery scheduled November 2024
- Presently only one (1) working front loader and no operating rear loader in the City's fleet

AMOUNT OF PROPOSED CONTRACT or TOTAL COST OF PROPOSAL: \$102,000.00

APPROPRIATION NUMBER: 4-01-E6-702-917

PROCUREMENT: Omnia #2019000319

IMPACT STATEMENT:

- Vehicles needed to transport Safe & Secure employees and inspectors to perform their daily duties

SUBJECT MATTER EXPERTS/ADVOCATES:

- N/A

COORDINATION:

- N/A

Prepared by: LATEEAH CHANDLER

856-757-7475

Name

Phone/Email

omniapartners.com/industries/government?tx_sol1%5Bsearch%3D%5Bkeyword%5D=BIG%20TRUCK&tx_sol1%5Bsearch%3D%5Bindustry%5D=3

BIG TRUCK
Reset search

Filter by category

DOWNLOAD ALL CONTRACTS

DOWNLOAD SEARCH RESULTS

Supplier	Contract Title	Contract Renewed Until	Potential Final Expiration	Lead Agency
BIGTRUCK RENTAL	Equipment Rentals and Related Products and Services	10/31/2025	10/31/2027	City of Charlotte, NC
bradyPLUS	Comprehensive Operational and Janitorial Supplies Solutions	04/30/2025	04/30/2025	Region 14 ESC - TX

This website stores cookies on your computer. These cookies are used to improve your website and provide more personalized services to you, both on this website and through other media. To find out more about the cookies we use, see our Privacy Policy.

Accept

Decline

A-39

DB:dh
03-12-24

**RESOLUTION AUTHORIZING A CONTRACT UNDER NEW JERSEY
STATE CONTRACT #88679 TO EB FENCE LIMITED LIABILITY CO**

WHEREAS, under N.J.S.A. 40A: 11-12, a municipality may, without advertising for bids, purchase materials, supplies or equipment under a contract entered into on behalf of the State by the Division of Purchase and Property in the Department of Treasury, State of New Jersey; and

WHEREAS, it has been certified by the Purchasing Agent of the City of Camden that the City seeks services from EB Fence Limited Liability Co., 23 Red Fox Trail, Sicklerville, NJ 08081 under State Contract #88679 for the purchase and replacement of fence surrounding Union Baseball Field (Malandra Hall Community Center) located at 1200 S. Merrimac Road & Tennessee Road; and

WHEREAS, the municipality seeks to purchase this service under said State Contract from EB Fence Limited Liability Co. for an amount not to exceed TWO HUNDRED EIGHT THOUSAND EIGHT HUNDRED TWENTY-FIVE DOLLARS AND FIFTY-FOUR CENTS (\$208,825.54); and

WHEREAS, there will be substantial savings by the municipality by purchasing under the State Contract and this procedure is in the best interest of the City of Camden; and

WHEREAS, pursuant to the directive of the Division of Local Government Services, a certification has been attached hereto which certifies that the funds for this expenditure are available and appropriated under the budget of the City of Camden under line item "H-26-BG-021-024", and said certification has been signed by the Chief Financial Officer and approved as to form by the City Attorney; now, therefore

BE IT RESOLVED, by the City Council of the City of Camden, that the City is hereby authorized to award a contract to from EB Fence Limited Liability Co., 23 Red Fox Trail, Sicklerville, NJ 08081 for the purchase and replacement of fence surrounding Union Baseball Field (Malandra Hall Community Center) located at 1200 S. Merrimac Road & Tennessee Road under State Contract #88679 for an amount not to exceed TWO HUNDRED EIGHT THOUSAND EIGHT HUNDRED TWENTY-FIVE DOLLARS AND FIFTY-FOUR CENTS (\$208,825.54).

BE IT FURTHER RESOLVED, that pursuant to N.J.S.A. 52:27BBB-23, a true copy of this Resolution shall be forwarded to the State Commissioner of Community Affairs, who shall have ten (10) days from the receipt thereof to veto this Resolution. All notices of veto shall be filed in the Office of the Municipal Clerk.

Date: March 12, 2024

The above has been reviewed
and approved as to form.

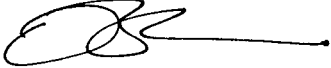

DANIEL S. BLACKBUURN
City Attorney

ANGEL FUENTES
President, City Council

ATTEST: _____
LUIS PASTORIZA
Municipal Clerk

CITY OF CAMDEN

CERTIFICATION AS TO THE AVAILABILITY OF FUNDS

I CERTIFY, DIRECTOR FOR THE FINANCE DEPARTMENT FOR THE CITY OF CAMDEN, THAT WITH RESPECT TO THE AWARD OF A CONTRACT OR EXPENDITURE OF FUNDS TO: EB FENCE LIMITED LIABILITY CO

THAT THE FUNDS ARE AVAILABLE AS OF THE DATE OF THIS RESOLUTION/CERTIFICATION, FROM ONE OF THE FOLLOWING:

- BUDGET APPROPRIATION: H-25-BG-021-024
AMOUNT: \$ 208,825.54
- DEDICATED BY RIDER:
AMOUNT:\$
- TEMPORARY RESERVE FOR STATE AND FEDERAL GRANT:
AMOUNT:\$
- CAPITAL ORDINANCE
AMOUNT:\$
- TRUST ACCOUNT:
AMOUNT: \$

DETERMINATION OF VALUE CERTIFICATION

I CERTIFY, AS CHIEF FINANCIAL OFFICER, THAT THE ANTICIPATED VALUE OF THE CONTRACT, OVER THE FULL LIFE, WILL BE: \$ 208,825.54

DESCRIPTION OF THE GOODS AND SERVICES TO BE PROCURED: RESOLUTION AUTHORIZING THE PURCHASE AND INSTALLATION OF FENCING MATERIAL FOR UNION BASEBALL FIELD (MALANDRA HALL COMMUNITY CENTER) THROUGH NEW JERSEY STATE CO-OPERATIVE

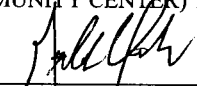

Gerald C. Seneski
Director of Finance

Date: 2/21



CITY OF CAMDEN — CITY COUNCIL ACTION REQUEST FORM

COUNCIL MEETING DATE: 03/12/2024

TO: City Council
FROM: KEITH L. WALKER, DIRECTOR OF PUBLIC WORKS

EB Fence, LLC

TITLE OF ORDINANCE/RESOLUTION: RESOLUTION AUTHORIZING THE PURCHASE AND INSTALLATION OF FENCING MATERIAL FOR UNION BASEBALL FIELD (MALANDRA HALL COMMUNITY CENTER) THROUGH NEW JERSEY STATE CO-OPERATIVE

Point of Contact:	Lateefah Chandler	Admin-Purchasing	856-757-7475	lachandl@ci.camden.nj.us
	Name	Department-Division-Bureau	Phone	Email

ENDORSEMENTS

	Recommend Approval (Y/N)	Signature	Date	Comments
Responsible Department Director	Y	<i>[Signature]</i>		
Supporting Department Director (if necessary)				
Director of Grants Management				
Qualified Purchasing Agent	Y	<i>Lateefah Chandler</i>	<i>2/21/2024</i>	
Director of Finance	Y	<i>[Signature]</i>	<i>2/21</i>	

Approved by: _____
 Business Administrator *[Signature]* *[Date]*

Attachments (list and attach all available):

1. Waiver Request Form Attached for State DCA/DLGS Approval - (If applicable)¹
2. Certification of Funds²
3. Addition supporting documents.

“Walk-on” note: All walk-on legislation must be pre-approved by the Business Administrator. The Department Director and Contact Person are jointly responsible for delivering all necessary documents to the City Clerk for distribution at the Council Meeting.

Received by: _____
 City Attorney *[Signature]* *[Date]*

¹ For Example: Form “A” - Request for approval of Employees Requiring Advice and Consent of Governing Body, Form “D” - Contract Request, Form “E” - Creation/Extension of Services, Form “G” - Grant Approval, Form “H” - Bond Ordinance or Contract Request, Form “I”, “Best Price Insurance Contracting” Model Ordinance
² Mandatory for any financial commitment to the City or expenditure of City Funds.

EXECUTIVE SUMMARY

TITLE OF ORDINANCE/RESOLUTION: RESOLUTION AUTHORIZING THE PURCHASE AND INSTALLATION OF FENCING MATERIAL FOR UNION BASEBALL FIELD (MALANDRA HALL COMMUNITY CENTER) THROUGH NEW JERSEY STATE CO-OPERATIVE

FACTS/BACKGROUND: (Executive level details. Short concise bullets)

- Removal of current fencing material and purchase and installation of 810 LF of black chain link fence with double drive gates for Union Baseball Field, S. Merrimcac & Tennessess Road (adjanct to Malandra Hall Community Center) from EB Fence Limited Liability Co. 23 Red Fox Trail, Sicklerville, NJ 08081 via NJSC #88679
- Purchase will replace current broken, damaged and outdated chain link fence surrounding Union Baseball Field/

AMOUNT OF PROPOSED CONTRACT or TOTAL COST OF PROPOSAL: \$208,825.54
APPROPRIATION NUMBER: H-25-BG-021-024
PROCUREMENT: N.J.S.A. 40A:11-12 - NJSC #88679

IMPACT STATEMENT:

- Improve the condition and safety of the athletic fields during recreational activities offered to the City's residents.

SUBJECT MATTER EXPERTS/ADVOCATES:

- Director Keith Walker, DPW

COORDINATION:

- N/A

Prepared by: LATEEAH CHANDLER

856-757-7475

Name

Phone/Email

ATTACHMENT D

**STATE OF NEW JERSEY
DEPARTMENT OF COMMUNITY AFFAIRS
DIVISION OF LOCAL GOVERNMENT SERVICES
CONTRACT REQUEST FORM**

This form must be filled out in its entirety and is intended to provide the Division with appropriate information to determine whether to approve a new or extended service. Please provide any additional information you believe will help the Division make an informed decision.

Municipality	CITY OF CAMDEN
--------------	----------------

Professional Service or EUS Type	N/A
Name of Vendor	EB FENCE LIMITED LIABILITY CO
Purpose or Need for service:	INSTALLATION AND PURCHASE OF 6" BLACK CHAIN LINK FENCE SURROUNDING UNION BASEBALL FIELD (ADJACENT TO MALANDRA HALL)
Contract Award Amount	\$208,825.54
Term of Contract	~3 MONTHS
Temporary or Seasonal	N/A
Grant Funded (attach appropriate documentation allowing for service through grant funds)	NO
Please explain the procurement process (i.e. bids, RFQ, competitive contracting, etc.)	NJSA 40A:11-12
Were other proposals received? If so, please attach the names and amounts for each proposal received?	FOX FENCE

Please attach the RFP, evaluation memoranda or evaluation forms used to evaluate the vendors and a list of all bidders and the bid amounts associated with each bidder.

If the lowest bidder was not selected, please have the appropriate personnel sign the certification on page 2.

_____ Date _____
Mayor's Signature*

_____ Date _____
Business Administrator/Manager Signature

*For direct appointments of the Governing Body, Council President or at the discretion of the Director, the most senior member of the Governing Body may sign the waiver in lieu of the Mayor.

The Financial Officer affirms that there is adequate funding available for this action.

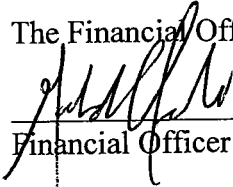

Financial Officer Signature

I certify that the vendor selected is in compliance with the adopted Pay to Play Ordinance and that the vendor was notified of any restrictions with respect to campaign contributions.

N/A N SSC
Certifying Officer Date _____

For LGS use only:

 Approved Denied

Date _____
Director or Designee,
Division of Local Government Services

Number Assigned _____

CAMDEN CITY
 520 MARKET STREET
 P O BOX 95120
 CAMDEN, NJ 08101-5120
 TEL (856)757-7000

AIBD

REQUISITION	
NO.	R2400303

SHIP TO	DEPT OF PUBLIC WORKS 101 NEWTON AVENUE CAMDEN, NJ 08103 ATTN: AMANDA FLEMING
VENDOR	VENDOR #: EBF01 EB FENCE LIMITED LIABILITY CO 23 RED FOX TRAIL SICKLERVILLE, NJ 08081

ORDER DATE: 01/26/24
 DELIVERY DATE:
 STATE CONTRACT:
 F.O.B. TERMS:

Curnal

QTY/UNIT	DESCRIPTION	ACCOUNT NO.	UNIT PRICE	TOTAL COST
1.00	T-Ball Field Fencing BLACK VINYL COATED CHAIN LINK FENCING 250 LF 4FT HIGH CLF W/TOPRAIL 200 LF 6FT HIGH CLF W/TOPRAIL 360 SQ FT CLF COMPLETE BACKSTOP 10'-20' - ALMZD 600 LF REMOVE FENCE COMPLETE	H-25-BG-021-024	34,381.4100	34,381.41
1.00	SOFTBALL FIELD FENCING BLACK VINYL COATED CHAIN LINK FENCING 500 LF 4FT HIGH CLF W/TOPRAIL 100 LF 6FT HIGH CLF W/TOPRAIL 50 LF 8FT HIGH CLF W/TOPRAIL 1200 SQ FT CLF COMPLETE BACKSTOP 10'-20'-ALMZD 900 LF REMOVE FENCE COMPLETE 72 SQ FT GATES ALL OTHER SIZES SWING	H-25-BG-021-024	68,400.7900	68,400.79
1.00	FIELD PERIMETER FENCING BLACK VINYL COATED CHAIN LINK FENCE 500 LF 6FT HIGH CLF W/TOPRAIL 500 LF REMOVE FENCE COMPLETE 180 SQ FT GATES ALL OTHER SIZES SLIDING	H-25-BG-021-024	34,557.8000	34,557.80
1.00	BASEBALL FIELD FENCING BLACK VINYL COATED CHAIN LINK FENCE 250 LF 4FT HIGH CLF W/TOPRAIL 400 LF 8FT HIGH CLF W/TOPRAIL 50 LF 8FT HIGH CLF W/TOPRAIL	H-25-BG-021-024	71,485.5400	71,485.54

1/29/2024

2024 JAN 29 PM 2:34
 PURCHASING
 CITY OF CAMDEN

Approved: 

I hereby certify that the work or supplies specified are necessary for the proper transaction of the business of this bureau or office.

[Signature] 1-26-24
 Department Head Date

Amanda C Fleming 1/26/24
 Receiver of Goods Date

FORWARD THIS COPY OF THE REQUISITION TO THE PURCHASING BUREAU

CAMDEN CITY
 520 MARKET STREET
 P O BOX 95120
 CAMDEN, NJ 08101-5120
 TEL (856)757-7000

TBD

REQUISITION	
NO.	R2400303.

Page # 2

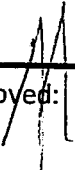
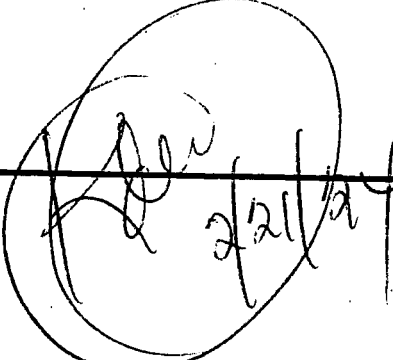
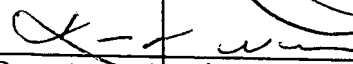
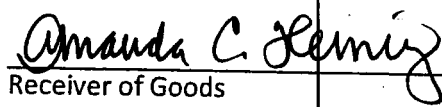
QTY/UNIT	DESCRIPTION	ACCOUNT NO.	UNIT PRICE	TOTAL COST
	1200 SQFT CLF COMPLETE BACKSTOP 10'-20' - ALMZD 700 LF REMOVE FENCE COMPLETE 132 SQFT GATES ALL OTHER SIZES SWING			
			TOTAL	208,825.54
Approved: 				
 Department Head	1-26-24 Date	I hereby certify that the work or supplies specified are necessary for the proper transaction of the business of this bureau or office.		
		 Receiver of Goods		1/26/24 Date
FORWARD THIS COPY OF THE REQUISITION TO THE PURCHASING BUREAU				

EB FENCE, LLC
FENCE: CHAIN LINK, ROCK FALL, WOODEN, VINYL, and ORNAMENTAL
STATE OF NEW JERSEY
PROPOSAL

PROJECT City of Camden T-Ball Field
DESCRIPTION Black Vinyl Coated Chain Link Fence

CONTRACT # A88679
T-NUMBER T0640

VENDOR: EB Fence, LLC
 23 Red Fox Trail
 Sicklerville, NJ 08081
 609-704-8884
 ebfence@comcast.net

DATE 8/7/2023
JOB #

ITEM	DESCRIPTION	COMM. CODE	Quantity	Unit	Unit Cost	Extended Cost
31	4 FT HIGH CLF W/ TOPRAIL - VINYL COATED	330-13-016932	250	LF	\$ 40.10	\$ 10,024.25
35	6 FT HIGH CLF W/ TOPRAIL - VINYL COATED	330-13-016938	200	LF	\$ 45.85	\$ 9,170.80
51	CLF COMPLETE BACKSTOP 10'-20' - ALMZD	330-13-086969	360	SQFT	\$ 25.35	\$ 9,126.36
62	REMOVE FENCE COMPLETE	330-13-016977	600	LF	\$ 10.10	\$ 6,060.00

TOTAL \$34,381.41

PREPARED BY: CHRISTOPHER MICHELINI

\$34,381.41

EB FENCE, LLC
FENCE: CHAIN LINK, ROCK FALL, WOODEN, VINYL, and ORNAMENTAL
STATE OF NEW JERSEY
PROPOSAL

PROJECT City of Camden Softball Field
DESCRIPTION Black Vinyl Coated Chain Link Fence

CONTRACT # A88679
T-NUMBER T0640

VENDOR: EB Fence, LLC
 23 Red Fox Trail
 Sicklerville, NJ 08081
 609-704-8884
 ebfence@comcast.net

DATE 8/7/2023
JOB #

ITEM	DESCRIPTION	COMM. CODE	Quantity	Unit	Unit Cost	Extended Cost
31	4 FT HIGH CLF W/ TOPRAIL - VINYL COATED	330-13-016932	500	LF	\$ 40.10	\$ 20,048.50
35	6 FT HIGH CLF W/ TOPRAIL - VINYL COATED	330-13-016938	100	LF	\$ 45.85	\$ 4,585.40
39	8 FT HIGH CLF W/ TOPRAIL - VINYL COATED	330-13-016944	50	LF	\$ 52.17	\$ 2,608.33
51	CLF COMPLETE BACKSTOP 10'-20' - ALMZD	330-13-086969	1200	SQFT	\$ 25.35	\$ 30,421.20
62	REMOVE FENCE COMPLETE	330-13-016977	900	LF	\$ 10.10	\$ 9,090.00
135	GATES ALL OTHER SIZES SWING	330-13-017103	72	SQFT	\$ 22.88	\$ 1,647.36

TOTAL \$68,400.79

PREPARED BY: CHRISTOPHER MICHELINI

\$68,400.79

EB FENCE, LLC
FENCE: CHAIN LINK, ROCK FALL, WOODEN, VINYL, and ORNAMENTAL
STATE OF NEW JERSEY
PROPOSAL

PROJECT City of Camden Field Perimeter Fence - Union Field
DESCRIPTION Black Vinyl Coated Chain Link Fence

CONTRACT # A88679
T-NUMBER T0640

VENDOR: EB Fence, LLC
 23 Red Fox Trail
 Sicklerville, NJ 08081
 609-704-8884
 ebfence@comcast.net

DATE 8/7/2023
JOB #

ITEM	DESCRIPTION	COMM. CODE	Quantity	Unit	Unit Cost	Extended Cost
35	6 FT HIGH CLF W/ TOPRAIL - VINYL COATED	330-13-016938	500	LF	\$ 45.85	\$ 22,927.00
62	REMOVE FENCE COMPLETE	330-13-016977	500	LF	\$ 10.10	\$ 5,050.00
136	GATES ALL OTHER SIZES SLIDING	330-13-017104	180	SQFT	\$ 36.56	\$ 6,580.80

TOTAL \$34,557.80

PREPARED BY: CHRISTOPHER MICHELINI

\$34,557.80

EB FENCE, LLC
FENCE: CHAIN LINK, ROCK FALL, WOODEN, VINYL, and ORNAMENTAL
STATE OF NEW JERSEY
PROPOSAL

PROJECT City of Camden Baseball Field
DESCRIPTION Black Vinyl Coated Chain Link Fence

CONTRACT # A88679
T-NUMBER T0640

VENDOR: EB Fence, LLC
 23 Red Fox Trail
 Sicklerville, NJ 08081
 609-704-8884
 ebfence@comcast.net

DATE 8/7/2023
JOB #

ITEM	DESCRIPTION	COMM. CODE	Quantity	Unit	Unit Cost	Extended Cost
31	4 FT HIGH CLF W/ TOPRAIL - VINYL COATED	330-13-016932	250 LF		\$ 40.10	\$ 10,024.25
35	6 FT HIGH CLF W/ TOPRAIL - VINYL COATED	330-13-016938	400 LF		\$ 45.85	\$ 18,341.60
39	8 FT HIGH CLF W/ TOPRAIL - VINYL COATED	330-13-016944	50 LF		\$ 52.17	\$ 2,608.33
51	CLF COMPLETE BACKSTOP 10'-20' - ALM2D	330-13-086969	1200 SQFT		\$ 25.35	\$ 30,421.20
62	REMOVE FENCE COMPLETE	330-13-016977	700 LF		\$ 10.10	\$ 7,070.00
135	GATES ALL OTHER SIZES SWING	330-13-017103	132 SQFT		\$ 22.88	\$ 3,020.16
TOTAL						\$71,485.54
PREPARED BY: CHRISTOPHER MICHELINI						\$71,485.54



All types of Gates, Manual & Electric
 Steel Bollards with Plastic Covers
 Aluminum & steel Ornamental Fence
 Tennis Court Fence & Screening
 Baseball Backstops
 Trash Enclosures

DOT Chain Link Fence
 Turnstiles, Manual & Electric
 Highway Guardrail, Steel or Timber
 PVC-Vinyl Fence, All colors
 High Rise Railing
 Wood Fence

New Jersey State Approved Co-op #65MCECCPS
NJ Contractors License No. 13VH02534400
ESCNJ 20/21-37 Fencing Purchase Installation and Repair
US Homeland Security Approved Fence Contractor (TWIC)

July 27 2023
 City of Camden
 520 Market St
 Camden NJ
 Phone: 856-757-7475
 856-541-9668 (fax)
 Email: Lito Moran LiMoran@ci.camden.nj.us
 Tamara Jefferson TaJeffer@ci.camden.nj.us
 Amanda Thompson-Fleming AmThomps@ci.camden.nj.us

Job Site: S. Merrimac and Tennessee Rd
 Camden NJ

Perimeter Fence

Description:
 Remove and Cart Away Approx. 810LF 6H Chain Link Fence
 Furnish and Install Approx. 810LF 6H All Black Chain Link Fence
 Furnish and Install (1) 6Hx16W Double Drive Gates
 (2x9 Wire, 3" Terminal Post, 2 1/2" Line Post, 1 5/8" Top and Bottom Rails)

Field 1

Description:
 Remove and Cart Away Approx. 125LF 4H Chain Link Fence
 Furnish and Install Approx. 125LF 4H All Black Chain Link Fence
 Furnish and Install (1) 4Hx12W Double Drive Gates
 Furnish and Install (2) Batters Bench Area 50LF 6H All Black Chain Link Fence
 Furnish and Install (2) 6Hx4W Walk Gates
 Furnish and Install 20x20x20 20H All Black Backstop
 (2x6 Wire, 3" Terminal Post, 2 1/2" Line Post, 1 5/8" Top and Bottom Rails)

A DIVISION OF ROSANDO FENCE CO., INC
 MORE THAN 70 YEARS
 Serving New Jersey, Eastern Pennsylvania, Northern New York & the 5-Boroughs of NYC
 417 CROOKS AVE CLIFTON NJ, 07011
 Phone: 973-779-9592 Fax: 973-340-3935 Email: fxfence417@aol.com



All types of Gates, Manual & Electric
Steel Bollards with Plastic Covers
Aluminum & steel Ornamental Fence
Tennis Court Fence & Screening
Baseball Backstops
Trash Enclosures

DOT Chain Link Fence
Turnstiles, Manual & Electric
Highway Guardrail, Steel or Timber
PVC-Vinyl Fence, All colors
High Rise Railing
Wood Fence

**New Jersey State Approved Co-op #65MCESCCPS
NJ Contractors License No. 13VH02534400
ESCNJ 20/21-37 Fencing Purchase Installation and Repair
US Homeland Security Approved Fence Contractor (TWIC)**

Field 2

Description:

Remove and Cart Away Approx. 470LF 4H Chain Link Fence
Remove and Cart Away Approx. 140LF 10H Chain Link Fence
Furnish and Install Approx. 470LF 4H All Black Chain Link Fence
Furnish and Install (1) 4Hx12W Double Drive Gates
Furnish and Install (2) Batters Bench Area 50LF 6H All Black Chain Link Fence
Furnish and Install (2) 6Hx4W Walk Gates
Furnish and Install (2) 4Hx4W Walk Gates
Furnish and Install Approx. 140LF 10H All Black Chain Link Fence
Furnish and Install 20x20x20 20H All Black Backstop
(2x6 Wire, 3" Terminal Post, 2 1/2" Line Post, 1 5/8" Top and Bottom Rails)

Field 3

Description:

Remove and Cart Away Approx. 450LF 4H Chain Link Fence
Remove and Cart Away Approx. 40LF 8H Chain Link Fence
Furnish and Install Approx. 450LF 4H All Black Chain Link Fence
Furnish and Install (1) 4Hx12W Double Drive Gates
Furnish and Install (2) Batters Bench Area 50LF 6H All Black Chain Link Fence
Furnish and Install (2) 6Hx4W Walk Gates
Furnish and Install Approx. 40LF 8H All Black Chain Link Fence
Furnish and Install (1) 6Hx12W Double Drive Gates
Furnish and Install 20x20x20 20H All Black Backstop
(2x6 Wire, 3" Terminal Post, 2 1/2" Line Post, 1 5/8" Top and Bottom Rails)

- All Materials to Meet Baseball/Softball Specs
- Layout to Meet Baseball/Softball Specs
- Lift on-site

Materials and Labor \$229,470.00

A DIVISION OF ROSANDO FENCE CO., INC
MORE THAN 70 YEARS
Serving New Jersey, Eastern Pennsylvania, Northern New York & the 5-Boroughs of NYC

417 CROOKS AVE CLIFTON NJ, 07011
Phone: 973-779-9592 Fax: 973-340-3935 Email: fxfence417@aol.com



All types of Gates, Manual & Electric
Steel Bollards with Plastic Covers
Aluminum & steel Ornamental Fence
Tennis Court Fence & Screening
Baseball Backstops
Trash Enclosures

DOT Chain Link Fence
Turnstiles, Manual & Electric
Highway Guardrail, Steel or Timber
PVC-Vinyl Fence, All colors
High Rise Railing
Wood Fence

**New Jersey State Approved Co-op #65MCESCCPS
NJ Contractors License No. 13VH02534400
ESCNJ 20/21-37 Fencing Purchase Installation and Repair
US Homeland Security Approved Fence Contractor (TWIC)**

Thank you;
Wilby Tapia,
INDUSTRIAL & COMMERCIAL ESTIMATOR
wtapia@foxfenceenterprisesinc.com

Accepted by: _____

Print Name: _____

Date: _____

A DIVISION OF ROSANDO FENCE CO., INC
MORE THAN 70 YEARS
Serving New Jersey, Eastern Pennsylvania, Northern New York & the 5-Boroughs of NYC
417 CROOKS AVE CLIFTON NJ, 07011
Phone: 973-779-9592 Fax: 973-340-3935 Email: fxfence417@aol.com



City of Camden Request For Funding

DATE: 08/16/23 DEPARTMENT REQUESTING FUNDS: DPW/Parks and Open Spaces

CONTACT PERSON: Amanda C. Fleming

PHONE: 856-757-7393

SOURCE OF FUNDS: CDBG AMOUNT OF REQUEST: \$ 436,471.81

TYPE OF ACTIVITY: Public Facility LOCATION/CENSUS TRACK: Union Baseball Field

NATIONAL OBJECTIVE:

(IDENTIFY ONE OF THE FOLLOWING NATIONAL OBJECTIVES: LOW/MOD BENEFIT; ELIMINATION OF SLUM AND BLIGHT OR URGENT NEED AND HOW THE PROJECT MEETS THE OBJECTIVE)

This activity benefits the low/mod income area residents in the Fairview section of the city.

PROJECT DESCRIPTION:

Union Field is located at Tennessee and S. Merrimac Road. Funding for this project would reinvigorate the park, replacing the existing fencing with new black vinyl fencing, made to today's specifications and regulations for baseball fields, replacing dug-out benches, and stands for the families to watch their children play.

This therefore is to request, \$436,471.81 of CDBG Funding.

GOALS/OBJECTIVES: (Include outputs and units of service, family or households)

The goal for this project is to provide the community with up-to-date, safe recreational amenities suitable for the neighborhood children, nearby school kids and the many sports teams who call Camden home.

BUDGET: (Provide budget summary and attach completed budget template form)

Fencing Replacement	\$215,000.00
Seating (Player Benches, stands)	\$40,000.00
Scoreboard	\$60,000.00
Concession Stand Design/Reno	\$121,471.81

TOTAL COST OF PROJECT: **\$436,471.81**

AUTHORIZATIONS

RELEVANT DIRECTOR: 

GRANTS MANAGEMENT: _____

DIRECTOR OF FINANCE: _____

2023 AUG 21 AM 10:45
CITY OF CAMDEN
GRANTS MANAGEMENT

Results

1-13 of 13 << < 1 > >>

Contract / Blanket #	Bid #	Description	Vendor	Type Code	Dollars Spent to Date	Organization	Status	Begin Date	End Date
88680		T0640 - FENCE: CHAIN LINK, ROCK FALL, WOODEN, VINYL AND ORNAMENTAL (INSTALL & REPLACE)	Consolidated Steel & Aluminum Fence Co., Inc.	RFP/NJCOOP/SBE	\$504,708.27	Division of Purchase and Property	3PS - Sent	03/01/2015	06/30/2024
88679		T0640 - FENCE: CHAIN LINK, ROCK FALL, WOODEN, VINYL AND ORNAMENTAL (INSTALL & REPLACE)	EB Fence LLC	RFP/NJCOOP/SBE	\$727,805.27	Division of Purchase and Property	3PS - Sent	03/01/2015	06/30/2024
87153		T1956 - LED SIGNAL INDICATIONS AND WARNING DEVICES	General Highway Products Inc.	RFP/NJCOOP	\$0.00	Division of Purchase and Property	3PS - Sent	09/15/2014	07/14/2024
49131		TSU01 - MACS GENERATED FOR PIMS/OTHER T-NOS FARM OPERATIONS, MEAT CONTRACT	State of New Jersey		\$4,071.00	Division of Purchase and Property	3PS - Sent	06/01/1996	06/30/2027

DB:dh
03-12-24

A-40

**RESOLUTION AUTHORIZING THE PURCHASE OF FIRE HOSES FROM
FIREFIGHTER 1 THROUGH NEW JERSEY STATE CO-OPERATIVE**

WHEREAS, under N.J.S.A. 40A: 11-12, a municipality may, without advertising for bids, purchase materials, supplies or equipment under a contract entered into on behalf of the State by the Division of Purchase and Property in the Department of Treasury, State of New Jersey; and

WHEREAS, it has been certified by the Purchasing Agent of the City of Camden that the City seeks to purchase various lengths of snap-tite fire hoses under State Contract #17-FLEET-00807 to replace unreparable failed fire hoses; and

WHEREAS, the municipality seeks to purchase this equipment under said State contract from FireFighter 1 for an amount not to exceed NINETY-FOUR THOUSAND FIVE HUNDRED THIRTY-NINE DOLLARS AND FIFTY CENTS (\$94,539.50); and

WHEREAS, there will be substantial savings by the municipality by purchasing under the State Contract and this procedure is in the best interest of the City of Camden; and

WHEREAS, pursuant to the directive of the Division of Local Government Services, a certification has been attached hereto which certifies that the funds for this expenditure are available and appropriated under the reserve for state and federal grant budget of the City of Camden under line items "H-25-BG-020-010", and said certification has been signed by the Chief Financial Officer and approved as to form by the City Attorney; now, therefore

BE IT RESOLVED, by the City Council of the City of Camden, that the City of Camden is hereby authorized to award a contract to Firefighter 1 to purchase various lengths of snap-tite fire hoses under State Contract #17-FLEET-00807 for an amount not to exceed NINETY-FOUR THOUSAND FIVE HUNDRED THIRTY-NINE DOLLARS AND FIFTY CENTS (\$94,539.50).

BE IT FURTHER RESOLVED, that pursuant to N.J.S.A. 52:27BBB-23, a true copy of this Resolution shall be forwarded to the State Commissioner of Community Affairs, who shall have ten (10) days from the receipt thereof to veto this Resolution. All notices of veto shall be filed in the Office of the Municipal Clerk.

Date: March 12, 2024

The above has been reviewed
and approved as to form.



DANIEL S. BLACKBURN
City Attorney

ANGEL FUENTES
President, City Council

ATTEST:

LUIS PASTORIZA
Municipal Clerk



CITY OF CAMDEN — CITY COUNCIL ACTION REQUEST FORM

COUNCIL MEETING DATE: 03/12/2024

TO: City Council
FROM: Chief Jesse Flax, Fire Department

TITLE OF ORDINANCE/RESOLUTION: RESOLUTION AUTHORIZING THE PURCHASE OF FIRE HOSES FROM FIREFIGHTER ONE THROUGH NEW JERSEY STATE CO-OPERATIVE

Point of Contact: Lateefah Chandler Admin-Purchasing 856-757-7475 lachandl@ci.camden.nj.us

Name	Department-Division-Bureau	Phone	Email
Lateefah Chandler	Admin-Purchasing	856-757-7475	lachandl@ci.camden.nj.us

ENDORSEMENTS

Responsible	Recommend Approval (Y/N)	Signature	Date	Comments
Department Director	Y		2-16-24	
Supporting Department Director (if necessary)				
Director of Grants Management				
Qualified Purchasing Agent	Y		2/21	
Director of Finance	Y			

Approved by: Business Administrator 2/22

Signature Date

Attachments (list and attach all available):

1. Waiver Request Form Attached for State DCA/DLGS Approval - (If applicable)¹
2. Certification of Funds²
3. Addition supporting documents.

"Walk-on" note: All walk-on legislation must be pre-approved by the Business Administrator. The Department Director and Contact Person are jointly responsible for delivering all necessary documents to the City Clerk for distribution at the Council Meeting.

Received by: City Attorney FEB 29 2024

Signature Date

¹ For Example: Form "A" - Request for approval of Employees Requiring Advice and Consent of Governing Body, Form "D" - Contract Request, Form "E" - Creation/Extension of Services, Form "G" - Grant Approval, Form "H" - Bond Ordinance or Contract Request, Form "I", "Best Price Insurance Contracting" Model Ordinance

² Mandatory for any financial commitment to the City or expenditure of City Funds.

EXECUTIVE SUMMARY

TITLE OF ORDINANCE/RESOLUTION: : RESOLUTION AUTHORIZING THE PURCHASE OF FIRE HOSES FROM FIREFIGHTER ONE THROUGH NEW JERSEY STATE CO-OPERATIVE

FACTS/BACKGROUND: (Executive level details. Short concise bullets)

- Purchase of various lengths of All American/Snap-Tite fire hoses from FireFirghter One, 34 Wilson Drive, Sparta, NJ 07871 via NJSC #17-Fleet-00807
- Purchase will replace unrepairable/destroyed fire hoses that failed testing as per NFPA 1962
- Hoses consist of Snap-Tite Hose Supreme & Snap-Tite HFX

AMOUNT OF PROPOSED CONTRACT or TOTAL COST OF PROPOSAL: \$94,539.50

APPROPRIATION NUMBER: H-25-BG-020-010

PROCUREMENT: N.J.S.A. 40A:11-12 - NJSC #17-FLET-00807

IMPACT STATEMENT:

- For the safety and well-being of the City's fire fighters

SUBJECT MATTER EXPERTS/ADVOCATES:

- Chief Jessie Flax, Fire Department

COORDINATION:

- N/A

Prepared by: LATEEAH CHANDLER

856-757-7475

Name

Phone/Email

**STATE OF NEW JERSEY
DEPARTMENT OF COMMUNITY AFFAIRS
DIVISION OF LOCAL GOVERNMENT SERVICES
CONTRACT REQUEST FORM**

This form must be filled out in its entirety and is intended to provide the Division with appropriate information to determine whether to approve a new or extended service. Please provide any additional information you believe will help the Division make an informed decision.

Municipality	CITY OF CAMDEN
Professional Service or EUS Type	N/A
Name of Vendor	FIREFIGHTER ONE
Purpose or Need for service:	PURCHASE OF VARIOUS LENGHTS OF ALL AMERICAN FIRE HOSES TO REPLACE UNREPAIRABLE AND WORN OUT HOSES
Contract Award Amount	\$96,539.50
Term of Contract	~2 MONTHS
Temporary or Seasonal	N/A
Grant Funded (attach appropriate documentation allowing for service through grant funds)	NO
Please explain the procurement process (i.e. bids, RFQ, competitive contracting, etc.)	NJSA 40A:11-12
Were other proposals received? If so, please attach the names and amounts for each proposal received?	NO

Please attach the RFP, evaluation memoranda or evaluation forms used to evaluate the vendors and a list of all bidders and the bid amounts associated with each bidder.

If the lowest bidder was not selected, please have the appropriate personnel sign the certification on page 2.

Mayor's Signature* Date _____

Business Administrator/Manager Signature Date _____

*For direct appointments of the Governing Body, Council President or at the discretion of the Director, the most senior member of the Governing Body may sign the waiver in lieu of the Mayor.

The Financial Officer affirms that there is adequate funding available for this action.

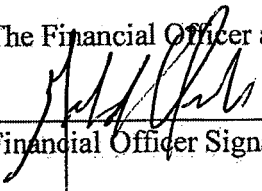

Financial Officer Signature

I certify that the vendor selected is in compliance with the adopted Pay to Play Ordinance and that the vendor was notified of any restrictions with respect to campaign contributions.

_____ *K/A NISSC* _____ Date _____
Certifying Officer

For LGS use only:

Approved Denied

_____ Date _____
Director or Designee,
Division of Local Government Services

Number Assigned _____

CAMDEN CITY

520 MARKET STREET
 P O BOX 95120
 CAMDEN, NJ 08101-5120
 TEL (856)757-7000

TBD

REQUISITION	
NO.	R2400097

SHIP TO	FRANK SANDROCK, DEPUTY CHIEF FIRE ADMINISTRATION 4 N 3RD STREET CAMDEN, NJ 08102
	VENDOR # : FIR60
VENDOR	FIREFIGHTER ONE LLC 34 WILSON DRIVE SPARTA, NJ 07871

ORDER DATE: 01/09/24
 DELIVERY DATE:
 STATE CONTRACT:
 F.O.B. TERMS:

CITY OF CAMDEN
 PURCHASING BUREAU
 2024 FEB 20 PM 3:06
 CITY OF CAMDEN
 PURCHASING BUREAU
 2024 FEB 20 PM 3:02

QTY/UNIT	DESCRIPTION	ACCOUNT NO.	UNIT PRICE	TOTAL COST
31.00 EA	PONN SUPREME DOUBLE JACKET HOS (31) PONN SUPREME DOUBLE JACKET HOSE - 1.75" DIA. WHITE 50FT 2.5 NST Catalog #: AAH-FS17X50C15N	H-25-BG-020-010	302.5000	9,377.50
20.00 EA	PONN SUPREME DBL JACKET HOSE Catalog #: AAH-FS25X50C25N	H-25-BG-020-010	441.6500	8,833.00
60.00 EA	SNAP-TITE HFX RUBBER HOSE YELL Catalog #: AAH-HFX40X100Y4	H-25-BG-020-010	1,272.1500	76,329.00
1.00	DESCRIPTION REPLACE UNREPAIRABLE / DESTROY FIRE HOSE THAT FAILED TESTING AS PER NFPA 1962 17-FLEET-00807-ALL AMERICA T-0790(17DPP00100) - FIREFIGHTER PROTECTION CLOTHING AND EQUIPMENT AWARD SUMMARY NJ STATE CONTRACT MASTER BLANKET #17-FLEET-00807 / ALL AMERICAN HOSE PRICE LIST DATE: 2022 / 45% DISCOUNT / CATEGORY 8 "NEW JERSEY STATE CONTRACT"	H-25-BG-020-010	0.0000	0.00
			TOTAL	94,539.50

Approved:

[Signature]
 2/15/24

Department Head

Date

2-15-24

I hereby certify that the work or supplies specified are necessary for the proper transaction of the business of this bureau or office.

Receiver of Goods

[Signature]

Date

2-15-24

FORWARD THIS COPY OF THE REQUISITION TO THE PURCHASING BUREAU

Initial Report _____ Revised Report Closing Report _____

Bureau of Grants Management Grant Summary Form

Grant Status Code: G

(green - g; yellow - y; red - r)

Department: Fire Department

Grant Administrator: Chief Jesse Flax Grant Administrator #: 757-7518

Project Name:		Fire Equipment			
Grant/Funding Agency Program:		CDBG Funding (Entitlement) FY21			
Grant Federal CFDA or State GIMS Number:		CFDA 14.218			
City Contract Date:		City Contract #:			
Application Resolution #:		Appropriation Code :		H-25-BG-022-020; H-25-BG-020-010; H-25-BG-021-004	
Funding Source:		CDBG FY 2022/21/20			
Pass Through:	Y or N	Source:			
Amount of Grant:		\$9,531.41 + \$12.83 + \$199,537.60			
Local Match:	Y or <input checked="" type="radio"/> N	Cash:	\$0	In-Kind:	
Budget Insertion Resolution # & Date:		Accepting Grant Resolution # MC:			
Term of Grant:		Location of Activity:		City wide	
Date of Analysis:	5-Feb-24	Reviewed By:	Kelly Mobley		

Summary:

20-Feb-24: The Fire Department is currently processing purchase requisition #R24000972 for Firefighter One LLC for the purpose of purchasing fire safety equipment in the amount of \$94,539.50 – NJ State Contract.

5-Feb-24: The Fire Department is currently processing purchase order #23-04382 for Firefighter One LLC for the purpose of purchasing fire safety equipment. 20 water rescue dry suits. Total cost \$29,949.60. This action will close out this purchase order. Also processing purchase requisition #R2400339 in the amount of \$9,642.00 for fire safety equipment

Funding was made available through the City's Entitlement of CDBG Funds for the FY 2 Program Year.

Time Lines:

Problematic Areas, Recommendations or Comments:

Initial Report _____ Revised Report Closing Report _____

Bureau of Grants Management Grant Summary Form

Grant Status Code: G
(green - g; yellow - y; red - r)



Firefighter 1

34 Wilson Drive Sparta New Jersey 07871
Phone (973) 940-3061 Fax: (973) 860-1388

QUOTE

SQ-00231013

Sales Rep: Mick Petrulla: mpetrulla@ff1.com

Quote Date 02/14/2024

Customer: Camden Fire Department
Bill to:
Street: 4 North 3rd. Street
City: Camden
State: NJ
Zip Code: 08102
Acct. # CFD08102

Delivery Address: 4 North 3rd. Street
Delivery City: Camden
Delivery State: NJ
Delivery Zip Code: 08102
Delivery Method: Drop Shipment
Payment Term 30 days

Part	Description	Qty	Price**	Total
AAH-FS17X50C15N	Ponn Supreme Double Jacket Hose - 1.75 in. Diameter White, Coated / 50' / 1.5 in NH Aluminum	31.00	302.50	9,377.50
NJ STATE CONTRACT STENCIL "CAMDEN FIRE DEPARTMENT" MONTH/YEAR				
AAH-FS25X50C25N	Ponn Supreme Double Jacket Hose - 2.5 in. Diameter White, Coated / 50 ft / 2.5 in NH Aluminum	20.00	441.65	8,833.00
NJ STATE CONTRACT STENCIL "CAMDEN FIRE DEPARTMENT" MONTH/YEAR				
AAH-HFX40X100Y40S	Snap-Tite HFX Rubber Hose Yellow / 4 in. / 4 in. Storz Coupled / 100 Foot	60.00	1,272.15	76,329.00
NJ STATE CONTRACT STENCIL "CAMDEN FIRE DEPARTMENT" MONTH/YEAR				
17-FLEET-00807-All America	T-0790 (17DPP00100) - Firefighter Protective Clothing and Equipment Award Summary NJ State Contract Master Blanket# 17-FLEET-00807 / All American Hose Price List Date: 2022 / 45% Discount / Category 8	1.00	0.00	0.00
NJ STATE CONTRACT				

Charge	Price

RETURN POLICY:

- Special Order or Custom items are not returnable.
- All Returns are subject to a 20% restocking fee.
- No returns will be accepted without an RMA # issued by FF1.
- No Returns will be accepted after 60 days from date of purchase.
- Returning party responsible for shipping related charges.
- Returned merchandise must be in NEW and RESALABLE condition for credit to be applied.

Sub Total	94,539.50
Charges	0.00
Tax Total	0.00
Total	94,539.50

Authorized Signature: _____

Printed Name: _____

Kelly Mobley

From: Kelly Mobley
Sent: Friday, February 16, 2024 7:54 AM
To: Blanca Aponte
Cc: Jesse Flax
Subject: RE: Grant Acct #: H-25-BG-020-010

Good morning Blanca. For the fire hoses the funding was to be taken from the following accounts:

H25-BG-020-010
H-25-BG-022-020
H-25-BG-021-020

Total allocated from these accounts: \$209,081.84

Purchase the following: Fire Hoses : \$58,222.80
Equipment for removal from entrapment (various): \$57,995.18 + \$42,785 +
\$9,642+ \$9,337.97
+ \$4,030.72 + \$19,168.17 (\$142,959.04)
Equipment to detect natural gas: \$7,900.00

Let me know if you have any further questions.

Kelly Mobley

Kelly Mobley
Coordinator for Federal and State Aid
Department of Finance
Bureau of Grants Management
City Hall – Suite 316 PO Box 95120
Camden, NJ 08101-5120
(856) 602-4521 (office)
(856) 676-6444 (cell)
(856) 968-6417 (fax)

From: Blanca Aponte <BlancaA@ci.camden.nj.us>
Sent: Thursday, February 15, 2024 12:15 PM
To: Kelly Mobley <KeMobley@ci.camden.nj.us>
Subject: Grant Acct #: H-25-BG-020-010

Kelly,

I believe the order pertains to the above mentioned grant account, Req #R2400097, the Chief added hoses by quantity, we should be covered, thank you. ☺

Account No	Date	Transaction Data/Comment	Description	Adopted Expended YTD Expended Curr	Amended Encumber YTD Requested YTD	Transfers Reimbrsd YTD Reimbrsd Curr Vendor/Reference	Modified Canceled Pd/Chrgd YTD	Balance YTD Unexpended	%Used	Trans Amount	Trans Balance	User
Continued												
H-25-B6-020-010 Fire Equipment												
12/13/23	RQ 23-03446	2 SHIPPING & HANDLING CHARGES	Cancelled			FIR60	FIREFIGHTER ONE LLC			350.00--	199,537.60	BA
12/13/23	RQ 23-03448	1 PERMIER WATER RESCUER PACKAGE	Cancelled			FIR60	FIREFIGHTER ONE LLC			36,410.00--	199,537.60	BA
12/13/23	RQ 23-03448	2 SAR BACKCOUNTRY / RED W/RAILS	Cancelled			FIR60	FIREFIGHTER ONE LLC			2,700.00--	199,537.60	BA
12/13/23	RQ 23-03448	3 EXFIL SAR BACKCOUNTRY W/RAILS	Cancelled			FIR60	FIREFIGHTER ONE LLC			5,200.00--	199,537.60	BA
12/14/23	RQ 23-03454	1 SNAP SUPREME ATTACH HOSE	Cancelled			DSE01	DIVAL SAFETY EQUIPMENT			8,246.00--	199,537.60	BA
12/14/23	RQ 23-03454	2 PONN SUPREME 2 1/2" HOSE 50'	Cancelled			DSE01	DIVAL SAFETY EQUIPMENT			6,480.00--	199,537.60	BA
12/14/23	RQ 23-03454	3 ALL AMERICAN HFX HOSE 4" 100'	Cancelled			DSE01	DIVAL SAFETY EQUIPMENT			26,250.00--	199,537.60	BA
12/14/23	RQ 23-03456	1 MAKITA HIGH PRESSURE INFLATOR	Cancelled			MUN36	MUNICIPAL EMERGENCY SERVICES			620.00--	199,537.60	BA
12/14/23	RQ 23-03456	10 MAKITA 18 VOLT BL 6PC KIT	Cancelled			MUN36	MUNICIPAL EMERGENCY SERVICES			6,288.00--	199,537.60	BA
12/14/23	RQ 23-03456	11 MAKITA 48PC SOCKET/METRIC SET	Cancelled			MUN36	MUNICIPAL EMERGENCY SERVICES			192.00--	199,537.60	BA
12/14/23	RQ 23-03456	12 MAKITA 1/4 ULTRA THIN METAL SA	Cancelled			MUN36	MUNICIPAL EMERGENCY SERVICES			468.00--	199,537.60	BA
12/14/23	RQ 23-03456	13 MAKITA ULTRA THIN CUT OFF WHEE	Cancelled			MUN36	MUNICIPAL EMERGENCY SERVICES			300.00--	199,537.60	BA
12/14/23	RQ 23-03456	14 MAKITA DIAMOND BLADE TURBO GEN	Cancelled			MUN36	MUNICIPAL EMERGENCY SERVICES			150.00--	199,537.60	BA
12/14/23	RQ 23-03456	15 MAKITA 9"DEMOLITION BLADE 8/10	Cancelled			MUN36	MUNICIPAL EMERGENCY SERVICES			858.00--	199,537.60	BA
12/14/23	RQ 23-03456	16 MAKITA CONTRACTOR GRADE BITSET	Cancelled			MUN36	MUNICIPAL EMERGENCY SERVICES			492.00--	199,537.60	BA
12/14/23	RQ 23-03456	17 MAKITA BIMETAL BAND SAW BLADE	Cancelled			MUN36	MUNICIPAL EMERGENCY SERVICES			252.00--	199,537.60	BA
12/14/23	RQ 23-03456	18 MAKITA 44 7/8 BIMETAL BAND SAW	Cancelled			MUN36	MUNICIPAL EMERGENCY SERVICES			324.00--	199,537.60	BA
12/14/23	RQ 23-03456	19 CUSTOM MAKITA USA BIMETAL BAND	Cancelled			MUN36	MUNICIPAL EMERGENCY SERVICES			84.00--	199,537.60	BA
12/14/23	RQ 23-03456	2 MAKITA LITHIUM ION BRUSHLESS CO	Cancelled			MUN36	MUNICIPAL EMERGENCY SERVICES			2,256.00--	199,537.60	BA
12/14/23	RQ 23-03456	20 SHIPPING & HANDLING CHANGES	Cancelled			MUN36	MUNICIPAL EMERGENCY SERVICES			250.00--	199,537.60	BA
12/14/23	RQ 23-03456	3 MAKITA REHAB COOLER BOX	Cancelled			MUN36	MUNICIPAL EMERGENCY SERVICES			860.00--	199,537.60	BA
12/14/23	RQ 23-03456	4 MAKITA 12V CXT MULTI CUTTER KI	Cancelled			MUN36	MUNICIPAL EMERGENCY SERVICES			984.00--	199,537.60	BA
12/14/23	RQ 23-03456	5 MAKITA 18V PORTABLE BAND SAW	Cancelled			MUN36	MUNICIPAL EMERGENCY SERVICES			1,260.00--	199,537.60	BA
12/14/23	RQ 23-03456	6 MAKITA 40V DEEP CUT PORTABLE	Cancelled			MUN36	MUNICIPAL EMERGENCY SERVICES			795.00--	199,537.60	BA
12/14/23	RQ 23-03456	7 MAKITA STEEL ROD FLUSH CUTTER	Cancelled			MUN36	MUNICIPAL EMERGENCY SERVICES			8,208.00--	199,537.60	BA
12/14/23	RQ 23-03456	8 MAKITA 40V 14" POWER CUTTER-BA	Cancelled			MUN36	MUNICIPAL EMERGENCY SERVICES			17,004.00--	199,537.60	BA
12/14/23	RQ 23-03456	9 MAKITA BACPAK POWER SUPPLY	Cancelled			MUN36	MUNICIPAL EMERGENCY SERVICES			1,140.00--	199,537.60	BA
12/21/23	PO 23-04700	1 Open ELKHART STANDPIPE BAG				DSE01	DIVAL SAFETY EQUIPMENT			11,401.20-	188,136.40	SZP
01/03/24	RQ R2400028	1 MERCEDES KRACKEN EXO SUPER II	App1: BA			UNK01	UNKNOWN VENDOR			16,456.80-	171,679.60	BA
01/09/24	RQ R2400097	1 PONN SUPREME DOUBLE JACKET HOS	App1: BA			FIR60	FIREFIGHTER ONE LLC			9,377.50-	162,302.10	BA
01/09/24	RQ R2400097	2 PONN SUPREME DBL JACKET HOSE	App1: BA			FIR60	FIREFIGHTER ONE LLC			8,833.00-	153,469.10	BA
01/09/24	RQ R2400097	3 SNAP-TITE HFX RUBBER HOSE YELL	App1: BA			FIR60	FIREFIGHTER ONE LLC			76,329.00-	77,140.10	BA
01/09/24	RQ R2400097	4 DESCRIPTION	App1: BA			FIR60	FIREFIGHTER ONE LLC			0.00	77,140.10	BA
01/09/24	RQ R2400099	1 11 STEP IRP TINS	Hold			DRA08	DRAGON RESCUE MANAGEMENT			130.00-	77,010.10	BA
01/09/24	RQ R2400099	2 WARD TROMBONE TOOL	Hold			DRA08	DRAGON RESCUE MANAGEMENT			560.00-	76,450.10	BA

Account No	Description	Adopted Expended YTD Expended Curr	Amended Encumber YTD Requested YTD	Transfers Reimbrsd YTD Reimbrsd Curr	Modified Canceled Pd/Chrgd YTD	Balance YTD Unexpended	%Used	Trans Amount	Trans Balance	User
Continued										
H-25-RG-020-010 Fire Equipment										
01/09/24 RQ R2400099	3 MODIFIED TROMBONE	Held		DRA08	DRAGON RESCUE MANAGEMENT			515.00-	75,935.10	BA
01/09/24 RQ R2400099	4 POLLING DEVICE	Held		DRA08	DRAGON RESCUE MANAGEMENT			2,140.00-	73,795.10	BA
01/09/24 RQ R2400099	5 ELEVATOR DOOR SIMULATOR	Held		DRA08	DRAGON RESCUE MANAGEMENT			2,410.00-	71,385.10	BA
01/09/24 RQ R2400099	6 OVERTHE OP PICK SET	Held		DRA08	DRAGON RESCUE MANAGEMENT			560.00-	70,825.10	BA
01/09/24 RQ R2400099	7 NO SHIPPING & HANDLING FEES	Held		DRA08	DRAGON RESCUE MANAGEMENT			0.00	70,825.10	BA
01/26/24 RQ R2400311	1 MAKITA HIGH PRESSURE INFLATOR	PO: 24-00515		MUN36	MUNICIPAL EMERGENCY SERVICES			620.00-*	70,825.10	BA
01/26/24 RQ R2400311	10 MAKITA 18 VOLT BL 6PC KIT	PO: 24-00515		MUN36	MUNICIPAL EMERGENCY SERVICES			6,288.00-*	70,825.10	BA
01/26/24 RQ R2400311	11 MAKITA 48PC SOCKET/METRIC SET	PO: 24-00515		MUN36	MUNICIPAL EMERGENCY SERVICES			192.00-*	70,825.10	BA
01/26/24 RQ R2400311	12 MAKITA 1/4 ULTRA THIN METAL SA	PO: 24-00515		MUN36	MUNICIPAL EMERGENCY SERVICES			468.00-*	70,825.10	BA
01/26/24 RQ R2400311	13 MAKITA ULTRA THIN CUT OFF WHEE	PO: 24-00515		MUN36	MUNICIPAL EMERGENCY SERVICES			300.00-*	70,825.10	BA
01/26/24 RQ R2400311	14 MAKITA DIAMOND BLADE TURBO GEN	PO: 24-00515		MUN36	MUNICIPAL EMERGENCY SERVICES			150.00-*	70,825.10	BA
01/26/24 RQ R2400311	15 MAKITA 9"DEMOLITION BLADE 8/10	PO: 24-00515		MUN36	MUNICIPAL EMERGENCY SERVICES			858.00-*	70,825.10	BA
01/26/24 RQ R2400311	16 MAKITA CONTRACTOR GRADE BITSET	PO: 24-00515		MUN36	MUNICIPAL EMERGENCY SERVICES			492.00-*	70,825.10	BA
01/26/24 RQ R2400311	17 MAKITA BIMETAL BAND SAW BLADE	PO: 24-00515		MUN36	MUNICIPAL EMERGENCY SERVICES			252.00-*	70,825.10	BA
01/26/24 RQ R2400311	18 MAKITA 44 7/8 BIMETAL BAND SAW	PO: 24-00515		MUN36	MUNICIPAL EMERGENCY SERVICES			324.00-*	70,825.10	BA
01/26/24 RQ R2400311	19 CUSTOM MAKITA USA BIMETAL BAND	PO: 24-00515		MUN36	MUNICIPAL EMERGENCY SERVICES			84.00-*	70,825.10	BA
01/26/24 RQ R2400311	2 MAKITA LITHIUM/ION BRUSHLESS CO	PO: 24-00515		MUN36	MUNICIPAL EMERGENCY SERVICES			2,256.00-*	70,825.10	BA
01/26/24 RQ R2400311	20 SHIPPING & HANDLING CHANGES	PO: 24-00515		MUN36	MUNICIPAL EMERGENCY SERVICES			250.00-*	70,825.10	BA
01/26/24 RQ R2400311	3 MAKITA REHAB COOLER BOX	PO: 24-00515		MUN36	MUNICIPAL EMERGENCY SERVICES			860.00-*	70,825.10	BA
01/26/24 RQ R2400311	4 MAKITA 12V CXT MULTI CUTTER KI	PO: 24-00515		MUN36	MUNICIPAL EMERGENCY SERVICES			984.00-*	70,825.10	BA
01/26/24 RQ R2400311	5 MAKITA 18V PORTABLE BAND SAW	PO: 24-00515		MUN36	MUNICIPAL EMERGENCY SERVICES			1,260.00-*	70,825.10	BA
01/26/24 RQ R2400311	6 MAKITA 40V DEEP CUT PORTABLE	PO: 24-00515		MUN36	MUNICIPAL EMERGENCY SERVICES			795.00-*	70,825.10	BA
01/26/24 RQ R2400311	7 MAKITA STEEL ROD FLUSH CUTTER	PO: 24-00515		MUN36	MUNICIPAL EMERGENCY SERVICES			8,208.00-*	70,825.10	BA
01/26/24 RQ R2400311	8 MAKITA 40V 14" POWER CUTTER-BA	PO: 24-00515		MUN36	MUNICIPAL EMERGENCY SERVICES			17,004.00-*	70,825.10	BA
01/26/24 RQ R2400311	9 MAKITA BACPAK POWER SUPPLY	PO: 24-00515		MUN36	MUNICIPAL EMERGENCY SERVICES			1,140.00-*	70,825.10	BA
01/31/24 RQ R2400339	1 ROCK-N-RESCUE 600' BLUE 1/2"	PO: 24-00516		MUN36	MUNICIPAL EMERGENCY SERVICES			2,600.00-*	70,825.10	BA
01/31/24 RQ R2400339	10 ROCK-N-RESCUE LARGE ROPE BAG	PO: 24-00516		MUN36	MUNICIPAL EMERGENCY SERVICES			280.00-*	70,825.10	BA
01/31/24 RQ R2400339	11 ROCK-N-RESCUE X-L ROPE BAG BLU	PO: 24-00516		MUN36	MUNICIPAL EMERGENCY SERVICES			240.00-*	70,825.10	BA
01/31/24 RQ R2400339	12 ROCK-N-RESCUE X-L ROPE BAG RED	PO: 24-00516		MUN36	MUNICIPAL EMERGENCY SERVICES			240.00-*	70,825.10	BA
01/31/24 RQ R2400339	13 ROCK-N-RESCUE GRAND LRG ROPE	PO: 24-00516		MUN36	MUNICIPAL EMERGENCY SERVICES			280.00-*	70,825.10	BA
01/31/24 RQ R2400339	14 CUSTOME YATES GEAR TECH RES II	PO: 24-00516		MUN36	MUNICIPAL EMERGENCY SERVICES			1,200.00-*	70,825.10	BA
01/31/24 RQ R2400339	15 SHIPPING & HANDLING CHARGES	PO: 24-00516		MUN36	MUNICIPAL EMERGENCY SERVICES			1,200.00-*	70,825.10	BA
01/31/24 RQ R2400339	16 SHIPPING & HANDLING CHARGES	PO: 24-00516		MUN36	MUNICIPAL EMERGENCY SERVICES			250.00-*	70,825.10	BA
01/31/24 RQ R2400339	2 ROCK-N-RESCUE 600' RED 1/2"	PO: 24-00516		MUN36	MUNICIPAL EMERGENCY SERVICES			1,950.00-*	70,825.10	BA
01/31/24 RQ R2400339	3 ROCK-N-RESCUE 300' GREEN 8MM	PO: 24-00516		MUN36	MUNICIPAL EMERGENCY SERVICES			340.00-*	70,825.10	BA

Account No	Description	Adopted Expended YTD Expended Curr	Amended Encumber YTD Requested YTD	Transfers Reimbrsd YTD Reimbrsd Curr	Modified Canceled Pg/Chrgd YTD	Balance YTD %Used Unexpended	Trans Amount	Trans Balance	User
H-25-RG-020-010 Fire Equipment									
01/31/24 RQ R2400339	4 ROCK-N-RESCUE 300' ORANGE 8MM PO: 24-00516			MUN36	MUNICIPAL EMERGENCY SERVICES		340.00-**-	70,825.10	BA
01/31/24 RQ R2400339	5 ROCK-N-RESCUE 300' BUE 8MM PO: 24-00516			MUN36	MUNICIPAL EMERGENCY SERVICES		340.00-**-	70,825.10	BA
01/31/24 RQ R2400339	6 ROCK-N-RESCUE 100' 1" TUBE NYLO PO: 24-00516			MUN36	MUNICIPAL EMERGENCY SERVICES		34.00-**-	70,825.10	BA
01/31/24 RQ R2400339	7 ROCK-N-RESCUE 100' 1" TUBE NEON PO: 24-00516			MUN36	MUNICIPAL EMERGENCY SERVICES		34.00-**-	70,825.10	BA
01/31/24 RQ R2400339	8 ROCK-N-RESCUE 100' 1" TUBE RED PO: 24-00516			MUN36	MUNICIPAL EMERGENCY SERVICES		34.00-**-	70,825.10	BA
01/31/24 RQ R2400339	9 CUSTOM YATES GEAR TECH RES II PO: 24-00516			MUN36	MUNICIPAL EMERGENCY SERVICES		280.00-**-	70,825.10	BA
02/02/24 PO 24-00515	1 Open MAKITA HIGH PRESSURE INFLATOR			MUN36	MUNICIPAL EMERGENCY SERVICES		620.00-	70,205.10	SZP
02/02/24 PO 24-00515	2 Open MAKITA LITHIUM ION BRUSHLESS CO			MUN36	MUNICIPAL EMERGENCY SERVICES		2,256.00-	67,949.10	SZP
02/02/24 PO 24-00515	3 Open MAKITA REHAB COOLER BOX			MUN36	MUNICIPAL EMERGENCY SERVICES		860.00-	67,089.10	SZP
02/02/24 PO 24-00515	4 Open MAKITA 12V CXT MULTI CUTTER KI			MUN36	MUNICIPAL EMERGENCY SERVICES		984.00-	66,105.10	SZP
02/02/24 PO 24-00515	5 Open MAKITA 18V PORTABLE BAND SAW			MUN36	MUNICIPAL EMERGENCY SERVICES		1,260.00-	64,845.10	SZP
02/02/24 PO 24-00515	6 Open MAKITA 40V DEEP CUT PORTABLE			MUN36	MUNICIPAL EMERGENCY SERVICES		795.00-	64,050.10	SZP
02/02/24 PO 24-00515	7 Open MAKITA STEEL ROD FLUSH CUTTER			MUN36	MUNICIPAL EMERGENCY SERVICES		8,208.00-	55,842.10	SZP
02/02/24 PO 24-00515	8 Open MAKITA 40V 14" POWER CUTTER-BA			MUN36	MUNICIPAL EMERGENCY SERVICES		17,004.00-	38,838.10	SZP
02/02/24 PO 24-00515	9 Open MAKITA BACPAK POWER SUPPLY			MUN36	MUNICIPAL EMERGENCY SERVICES		1,140.00-	37,698.10	SZP
02/02/24 PO 24-00515	10 Open MAKITA 18 VOLT BL 6PC KIT			MUN36	MUNICIPAL EMERGENCY SERVICES		6,288.00-	31,410.10	SZP
02/02/24 PO 24-00515	11 Open MAKITA 48PC SOCKET/METRIC SET			MUN36	MUNICIPAL EMERGENCY SERVICES		192.00-	31,218.10	SZP
02/02/24 PO 24-00515	12 Open MAKITA 1/4 ULTRA THIN METAL SA			MUN36	MUNICIPAL EMERGENCY SERVICES		468.00-	30,750.10	SZP
02/02/24 PO 24-00515	13 Open MAKITA ULTRA THIN CUT OFF WHEE			MUN36	MUNICIPAL EMERGENCY SERVICES		300.00-	30,450.10	SZP
02/02/24 PO 24-00515	14 Open MAKITA DIAMOND BLADE TURBO GEN			MUN36	MUNICIPAL EMERGENCY SERVICES		150.00-	30,300.10	SZP
02/02/24 PO 24-00515	15 Open MAKITA 9" DEMOLITION BLADE 8/10			MUN36	MUNICIPAL EMERGENCY SERVICES		858.00-	29,442.10	SZP
02/02/24 PO 24-00515	16 Open MAKITA CONTRACTOR GRADE BITSET			MUN36	MUNICIPAL EMERGENCY SERVICES		492.00-	28,950.10	SZP
02/02/24 PO 24-00515	17 Open MAKITA BIMETAL BAND SAW BLADE			MUN36	MUNICIPAL EMERGENCY SERVICES		252.00-	28,698.10	SZP
02/02/24 PO 24-00515	18 Open MAKITA 44 7/8 BIMETAL BAND SAW			MUN36	MUNICIPAL EMERGENCY SERVICES		324.00-	28,374.10	SZP
02/02/24 PO 24-00515	19 Open CUSTOM MAKITA USA BIMETAL BAND			MUN36	MUNICIPAL EMERGENCY SERVICES		84.00-	28,290.10	SZP
02/02/24 PO 24-00515	20 Open SHIPPING & HANDLING CHANGES			MUN36	MUNICIPAL EMERGENCY SERVICES		250.00-	28,040.10	SZP
02/02/24 PO 24-00516	1 Open ROCK-N-RESCUE 600' BLUE 1/2"			MUN36	MUNICIPAL EMERGENCY SERVICES		2,600.00-	25,440.10	SZP
02/02/24 PO 24-00516	2 Open ROCK-N-RESCUE 600' RED 1/2"			MUN36	MUNICIPAL EMERGENCY SERVICES		1,950.00-	23,490.10	SZP
02/02/24 PO 24-00516	3 Open ROCK-N-RESCUE 300' GREEN 8MM			MUN36	MUNICIPAL EMERGENCY SERVICES		340.00-	23,150.10	SZP
02/02/24 PO 24-00516	4 Open ROCK-N-RESCUE 300' ORANGE 8MM			MUN36	MUNICIPAL EMERGENCY SERVICES		340.00-	22,810.10	SZP
02/02/24 PO 24-00516	5 Open ROCK-N-RESCUE 300' BUE 8MM			MUN36	MUNICIPAL EMERGENCY SERVICES		340.00-	22,470.10	SZP
02/02/24 PO 24-00516	6 Open ROCK-N-RESCUE 100' 1" TUBE NYLO			MUN36	MUNICIPAL EMERGENCY SERVICES		34.00-	22,436.10	SZP
02/02/24 PO 24-00516	7 Open ROCK-N-RESCUE 100' 1" TUBE NEON			MUN36	MUNICIPAL EMERGENCY SERVICES		34.00-	22,402.10	SZP
02/02/24 PO 24-00516	8 Open ROCK-N-RESCUE 100' 1" TUBE RED			MUN36	MUNICIPAL EMERGENCY SERVICES		34.00-	22,368.10	SZP
02/02/24 PO 24-00516	9 Open CUSTOM YATES GEAR TECH RES II			MUN36	MUNICIPAL EMERGENCY SERVICES		280.00-	22,088.10	SZP

Continued

Account No	Description	Adopted Expended YTD	Amended Encumber YTD	Transfers Reimbrsd YTD	Modified Canceled Pd/Chrgd YTD	Balance YTD %Used Unexpended	Trans Amount	Trans Balance	User
Date	Transaction Data/Comment	Expended Curr	Requested YTD	Reimbrsd Curr	Vendor/Reference				
Continued									
H-25-BG-020-010	Fire Equipment								
02/02/24	PO 24-00516 10 Open	ROCK-N-RESCUE LARGE ROPE BAG MUM36			MUNICIPAL EMERGENCY SERVICES		280.00-	21,808.10	SZP
02/02/24	PO 24-00516 11 Open	ROCK-N-RESCUE X-L ROPE BAG BLU MUM36			MUNICIPAL EMERGENCY SERVICES		240.00-	21,568.10	SZP
02/02/24	PO 24-00516 12 Open	ROCK-N-RESCUE X-L ROPE BAG RED MUM36			MUNICIPAL EMERGENCY SERVICES		240.00-	21,328.10	SZP
02/02/24	PO 24-00516 13 Open	ROCK-N-RESCUE GRAND LRG ROPE MUM36			MUNICIPAL EMERGENCY SERVICES		280.00-	21,048.10	SZP
02/02/24	PO 24-00516 14 Open	CUSTOME YATES GEAR TECH RES II MUM36			MUNICIPAL EMERGENCY SERVICES		1,200.00-	19,848.10	SZP
02/02/24	PO 24-00516 15 Open	SHIPPING & HANDLING CHARGES MUM36			MUNICIPAL EMERGENCY SERVICES		1,200.00-	18,648.10	SZP
02/02/24	PO 24-00516 16 Open	SHIPPING & HANDLING CHARGES MUM36			MUNICIPAL EMERGENCY SERVICES		250.00-	18,398.10	SZP
02/13/24	RQ R2400451 1 ZODIAC ERB400 REIGID FLOOR INF Appl: BA				FIREFIGHTER ONE LLC		13,335.18-	5,062.92	BA
02/13/24	RQ R2400451 2 SHIPPING & HANDLING CHARGES Appl: BA				FIREFIGHTER ONE LLC		350.00-	4,712.92	BA
Control: N0C	Total	0.00	0.00	199,537.60	199,537.60	4,712.92	32	199,537.60	
Department: 020	HUD CD8G - 2020 Total					4,712.92	32	199,537.60	
CAFR: BG	Total	0.00	0.00	199,537.60	199,537.60	4,712.92	32	199,537.60	
Fund: 25	Budgeted Total	0.00	0.00	199,537.60	199,537.60	4,712.92	32	199,537.60	
Fund: 25	Non-Budgeted Total	0.00	0.00	0.00	0.00	0.00	0	0.00	
Fund: 25	Total	0.00	0.00	199,537.60	199,537.60	4,712.92	32	199,537.60	

CAMDEN CITY
Budget Account Status/Transaction Audit Trail Including Requisition Items

Account No	Description	Adopted Expended YTD Expended Curr	Amended Encumber YTD Requested YTD Vendor/Reference	Transfers Reimbrsd YTD Reimbrsd Curr	Modified Canceled Pd/Chrgd YTD	Balance YTD %Used Unexpended	Trans Amount	Trans Balance	User
	Final Budgeted	0.00 0.00 0.00	0.00 63,828.20 130,996.48	199,537.60 0.00 0.00	199,537.60 0.00 63,828.20	4,712.92 199,537.60	32		
	Final Non-Budgeted	0.00 0.00 0.00	0.00 0.00 0.00	0.00 0.00 0.00	0.00 0.00 0.00	0.00 0.00	0		
	Final Total	0.00 0.00 0.00	0.00 63,828.20 130,996.48	199,537.60 0.00 0.00	199,537.60 0.00 63,828.20	4,712.92 199,537.60	32		

17-FOOD-00262	17DPP00111	T0114 - LIBRARY & SCHOOL SUPPLIES	United Supply Corp.	RFP	\$75,094.16	Division of Purchase and Property	3PS - Sent	08/31/2017	08/30/2024
17-FOOD-00248	17DPP00111	T0114 - LIBRARY & SCHOOL SUPPLIES	Kaplan Early Learning Company	RFP/NJ/COOP	\$7,541.74	Division of Purchase and Property	3PS - Sent	08/23/2017	08/22/2024
17-FOOD-00042		T0077 - FUEL OIL #2 - HEATING	Riggins Inc.	RFP/NJ/COOP	\$0.00	Division of Purchase and Property	3PS - Sent	07/01/2012	06/30/2018
17-FLEET-00807	17DPP00100	T0790 Firefighter Protective Clothing and Equipment	Firefighter One LLC	RFP/NJ/COOP	\$405,028.07	Division of Purchase and Property	3PS - Sent	06/15/2019	06/14/2024
17-FLEET-00792	17DPP00046	T0106 - Law Enforcement Firearms Equipment and Supplies	All Fleet Solutions LLC	RFP	\$0.00	Division of Purchase and Property	3PS - Sent	05/15/2019	05/13/2024
17-FLEET-00740	17DPP00046	T0106 - Law Enforcement Firearms Equipment and Supplies	Lawmen Supply Company of New Jersey Inc.	RFP	\$21,498,937.56	Division of Purchase and Property	3PS - Sent	05/15/2019	05/13/2024